

REV.	ECN NO.	APPD.

A  
B  
C  
D  
E  
F

1 2 3 4 5 6 7 8

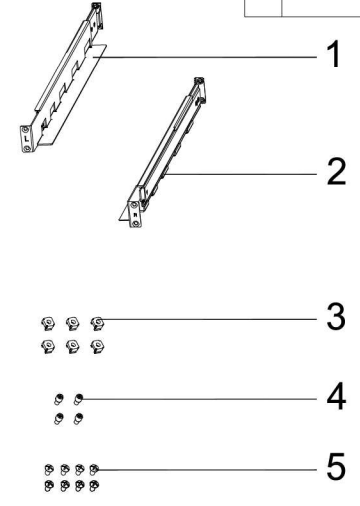
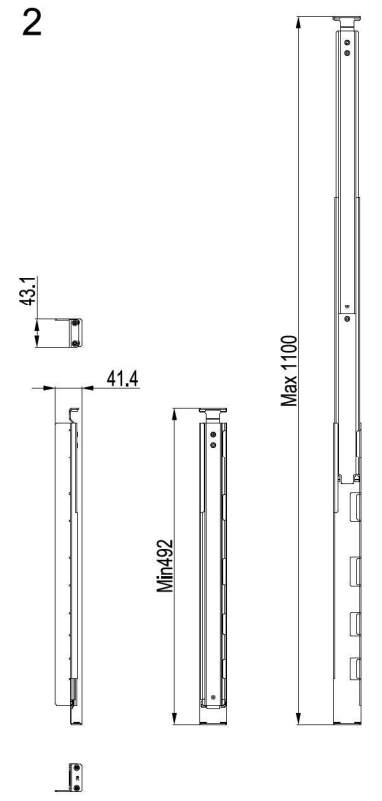
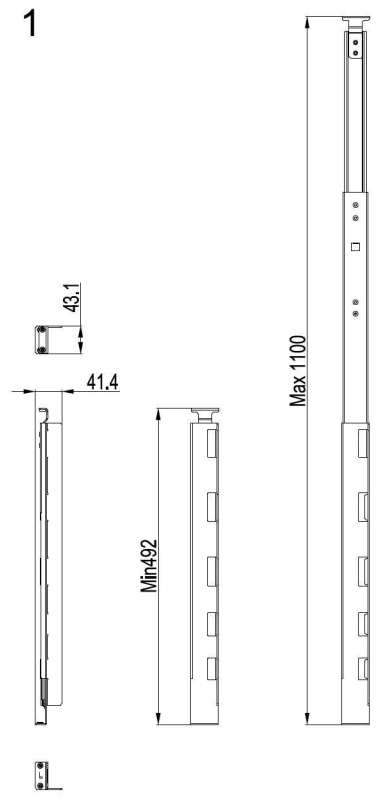

NOTES:  
 1. UNIT DIMENSIONS:492mm(D)x 41.4 mm(W)x 43.1mm(H);  
 2. UNIT WEIGHT: 1.89KG;  
 3. UNIT LOAD BEARING:Max 60kg;  
 4. SHIPPING DIMENSIONS:500mm(D) x95mm(W) x 55mm(H);  
 5. SHIPPING WEIGHT:2.15KG

Item	Name	Material	Surface finish	Surface Color
1	Left rail kit	SECC/SGCC t=1.6mm	POWDER COATING	Metal color
2	Right rail kit	SECC/SGCC t=1.6mm	POWDER COATING	Metal color
3	Cage nut	Spring steel	Plated-Ni	Silvery
4	Fixing stud	Low-carbon steel	Plated-Ni	Silvery
5	M6 screws	Iron	Plated-Ni	Silvery

1 2 3 4 5 6 7 8