

M90U-80 & 140 Modular Online Three-Phase UPS

15-140kVA Models

User & Installation Manual

Table of Contents

1. Safety.....	4
1.1 Important Safety Instructions.....	4
1.2 EMC.....	4
1.3 Installation Information.....	4
1.4 Maintenance.....	4
1.5 Recycling the Used Battery.....	5
2. Installation.....	5
2.1 Initial Inspection.....	5
2.2 Installation Environment.....	5
2.3 Unpacking.....	6
2.4 Moving the Cabinet.....	8
2.5 Types of UPS Cabinet.....	9
2.6 Exterior.....	9
2.7 Internal Mechanisms.....	12
2.8 Control Panel.....	15
2.9 Introduction of Modules.....	16
2.10 Power Cable.....	20
2.11 Wiring.....	22
2.12 Power Module Installation.....	23
2.12 Battery Module Installation.....	23
3. Operation Mode and UPS Operation.....	26
3.1 Block Diagram of UPS.....	26
3.2 Operation Mode.....	27
3.3 UPS Operation.....	30
4. Control Panel and Display Description.....	40
4.1 Introduction.....	40
4.2 Screen Description.....	41
4.3 Alarm List.....	62

4.4 History Record.....	64
5. Interface and Communication.....	65
5.1 Dry Contact Port.....	65
5.2 Extra Comm. Slot.....	67
5.3 Local Communication Ports – RS232 & USB.....	67
5.4 SNMP Slot.....	67
6. Troubleshooting.....	68
7. Service.....	70
7.1 Replacement Procedures Of Power Module.....	71
7.2 Replacement Procedures Of STS Module.....	71
7.3 Replacement Procedures Of Battery Module.....	71
7.4 Replacement Procedures Of Air Filter.....	71
8. Specifications.....	72
9. Obtaining Service.....	74
10. Xtreme Power Conversion Limited Warranty.....	75

1 Safety

1.1 Important Safety Instructions

This UPS contains LETHAL VOLTAGES. All repairs and service must be performed by AUTHORIZED SERVICE PERSONNEL ONLY. There are NO USER SERVICEABLE PARTS inside the UPS.

WARNING:

- The UPS designed for commercial and industrial purpose, it is forbidden to apply for any life sustainment and support.
- The UPS system contains its own energy source. The output terminals may carry live voltage even when the UPS is disconnected from an AC source.
- To reduce the risk of fire or electrical shock, the UPS installation has to be in a room where temperature and humidity are controlled, Ambient temperature must not exceed 40°C. The system is only for indoor use.
- Ensure all power is disconnected before installation or service.
- Service and maintenance should be performed by qualified personnel only.

Before working on this circuit

- Isolate Uninterruptible Power System (UPS) from all AC and DC voltages.
- Check for Hazardous Voltage between all terminals including the protective earth.



Risk of Voltage Backfeed

The isolation device must be able to carry the UPS input current.

1.2 EMC

WARNING:

This is a product for commercial and industrial application in the second environment - installation restrictions or additional measures may be needed to prevent disturbances.

1.3 Installation Information

WARNING:

- Installation must be performed by qualified personnel only.
- The cabinets must be installed on a level floor suitable for computer or electronic equipment.
- The UPS cabinet is heavy. If unloading instructions are not closely followed, cabinet may cause serious injury.
- Do not tilt the cabinets more than 10 degrees from side to side
- Before applying electrical power to the UPS, make sure the Ground conductor is properly installed.
- Installation and Wiring must be performed in accordance with the local, state and national laws electrical laws and regulations.
- The disconnection device should be chosen based on the input current and should break line and neutral conductors - four poles for three phases.

1.4 Maintenance

- Only qualified service personnel should perform the battery installation.
- The following PRECAUTIONS should be observed:

1. Remove watches, rings, or other metal objects.
 2. Use tools with insulated handles.
 3. Wear rubber gloves and boots.
 4. Do not lay tools or metal parts on top of batteries or battery cabinets.
 5. Disconnect the charging source prior to connecting or disconnecting terminal.
 6. Ensure the battery is inadvertently grounded. If it is, remove the source of grounding. Contact with any part of the ground might result in electrical shock. The likelihood of such shock can be prevented if such grounds are removed during installation and maintenance.
- UPS is designed to supply power even when disconnected from the utility power. Disconnect the utility and DC power, authorized service personnel should attempt internal access to the UPS.
 - Do not disconnect the batteries while the UPS is in Battery mode.
 - Batteries can result in a risk of electrical shock or burn from high short circuit current.
 - When replacing batteries, use the same number of sealed, lead-acid batteries.
 - Do not open or mutilate the battery. Released electrolyte is harmful to the skin and eyes, and may be toxic.

1.5 Recycling the Used Battery

- Do not dispose of the battery in a fire. Battery may explode. Proper disposal of battery is required. Refer to your local codes for disposal requirements.
- Do not open or mutilate the battery. Released electrolyte is harmful to the skin and eyes. It may be toxic.
- Do not discard the UPS or the UPS batteries in the trash. This product contains sealed, lead-acid batteries and must be disposed properly. For more information, contact your local recycling/reuse or hazardous waste center.
- Do not discard waste electrical or electronic equipment (WEEE) in the trash. For proper disposal, contact your local recycling/reuse or hazardous waste center.

2 Installation

2.1 Initial Inspection

1. Visually examine for any damage inside and outside of packaging from the process of transportation. If any damage, report it to the carrier immediately.
2. Verify the product label and confirm the consistency of the equipment.
3. If the equipment needs to be returned, carefully repack the equipment by using the original packing material.

2.2 Installation Environment

1. The UPS is designed for indoor use only and should be located in a clean environment with adequate ventilation to keep the environmental parameters within the required specification.
2. Make sure that transportation routes (e.g. corridor, door gate, elevator, etc.) and installation area can accommodate and bear the weight of the UPS, the external battery cabinet and handling equipment.
3. The UPS uses forced convection cooling by internal fans. Cooling air enters the module through ventilation grills located at the front of the cabinet and exhausted through grills located in the rear part of the cabinet. Please do not block the ventilation holes.
4. Ensure that the installation area is adequate for maintenance and ventilation.
5. Operating temperature range is 0–40°C (32–104°F) and humidity up to 95%. Reference M90U altitude and temperature derating chart for specific applications. Lead Acid battery life is reduced above 25°C (77°F).
6. If necessary, install a system of ventilation fans to avoid excessive room temperature or humidity. Air filters are necessary if the UPS is operated in a dusty environment.
7. It is recommended that you parallel the external battery cabinets to the UPS. The following instructions of

clearances are suggested:

- Keep a clearance of 36" from the top of the UPS for maintenance, wiring and ventilation.
 - Keep a clearance of 36" from the back of the UPS and the external battery cabinets for ventilation.
 - Keep a clearance of 36" from the front of the UPS and the external battery cabinets for maintenance and ventilation.
8. For safety concerns, we suggest that you shall:
 - Equip with CO2 or dry powder fire extinguishers near the installation area.
 - Install the UPS in an area where the walls, floors and ceilings were constructed by fireproof materials.
 9. Do not allow unauthorized personnel to enter the installation area. Assign specific personnel to keep the UPS key.

2.3 Unpacking

1. Use a forklift to move the product to installation area. Please make sure the lift bearing capacity of forklift is sufficient.
2. Please follow the order in the figures below to remove carton and packing material.

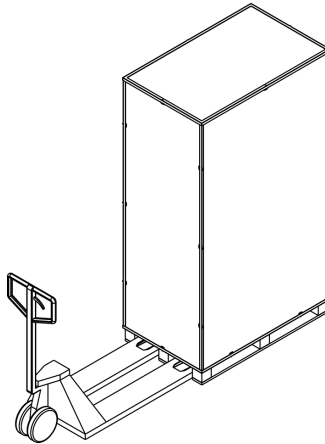

Figure 2-1

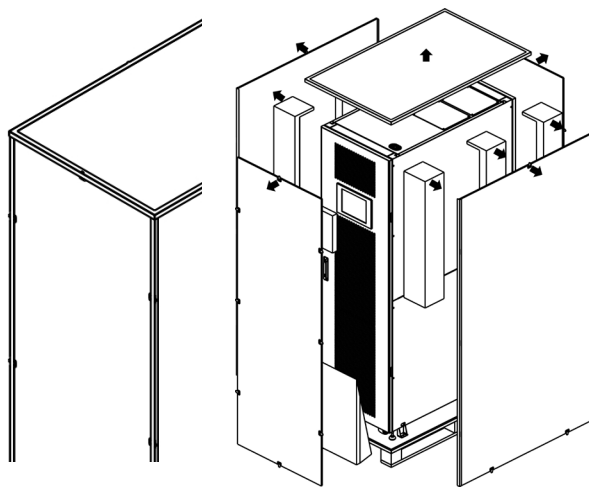

Figure 2-2

- Put the included ramp in the front of the cabinet. Then, remove two side panels. Refer to Figure 2-3.

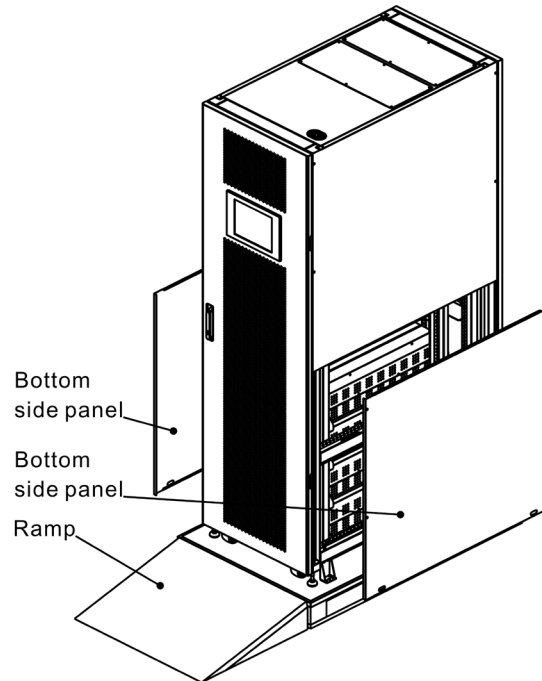

Figure 2-3

- Remove 4 shipping brackets and loosen leveling feet by rotating them counterclockwise. Then, move the cabinet from the pallet. Refer to Figure 2-4.
- To fix the cabinet in position, simply rotate leveling feet clockwise. Refer to Figure 2-5.

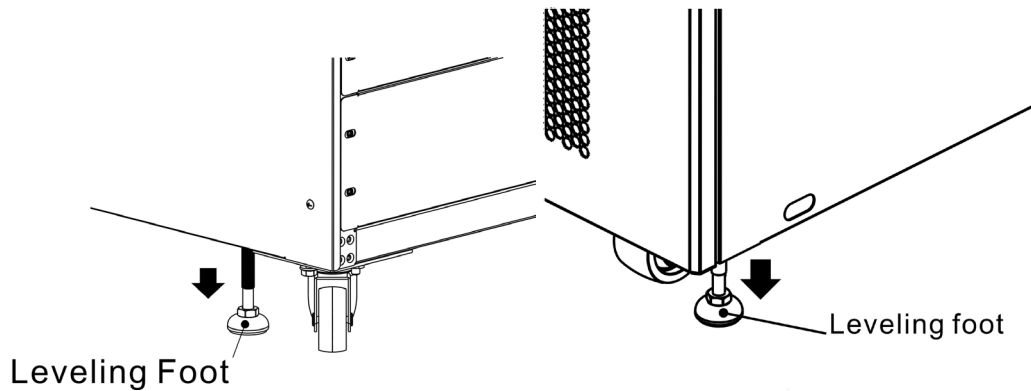

Figure 2-4

Figure 2-5

2.4 Moving the Cabinet

Warning

The UPS is secured on the pallet with 4 shipping brackets. When removing it, pay attention to the movement of the casters to avoid accidents.

The cabinet can be pushed forward or backward only. Pushing it sideways is not allowed. When pushing the cabinet, be careful not to tip it as the center of gravity is high.

1. If you need to move the UPS over a long distance, please use appropriate equipment like a forklift. Do not use the UPS casters to move over a long distance.
2. After the UPS has been removed from the pallet to ground, we suggest that at least three people move the UPS to the installation area. One person holds a lateral side of the UPS, another holds the other lateral side of the UPS, and the other person pushes the UPS either from the front side or from the back side to the installation area and avoid tipping the UPS.
3. The casters are designed to move on level ground. Do not move the UPS on an uneven surface. This might cause damage to the casters. Toppling the UPS could also damage the unit.
4. Ensure that the weight of UPS is within the designated bearing capacity of any handling equipment.
5. At the bottom of the UPS, the four casters help you to move the UPS to a designated area. Before you move the UPS, please turn the four leveling feet counterclockwise to raise them off the ground. This protects the leveling feet from damage when moving the UPS. Refer to Figure 2-6.

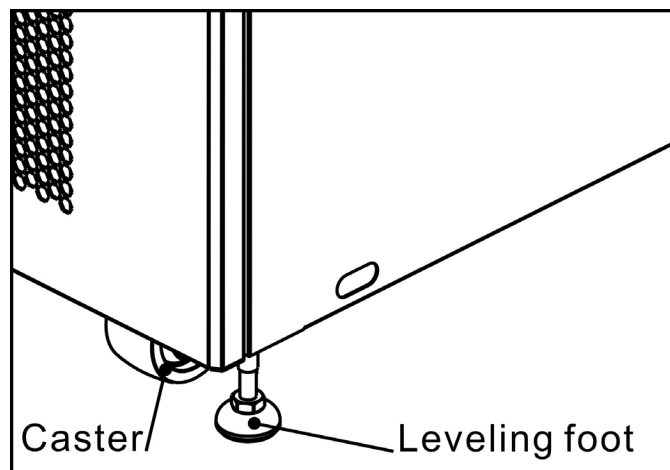

Figure 2-6

2.5 Types of UPS Cabinet

There are two types of UPS cabinets. The M90U-80 has slots for (4) power modules and (16) battery modules. The M90U-140 has slots for (8) power modules (batteries are contained in a separate cabinet).

	M90U-80	M90U-140
Cabinet		
Cabinet Height	42U	42U
Switch Unit / MBS (1)	1	1
STS (2)	1	1
Max. Power Module (3)	4	8
Battery Module (4)	16	N/A

2.6 Exterior

In the front of the UPS, there are control interface (LCD Panel) and door lock. The casters at the bottom of the UPS cabinet can be used to move over short distances. There are four leveling feet to fix and stabilize the UPS cabinet on the ground. Refer to Figure 2-7.

Inside the cabinet, there are input, output and maintenance bypass breakers, STS Module, Power Module slots and Battery module slots (Battery module for M90U-80 only). All wiring terminal blocks are located in the rear and top of cabinet.

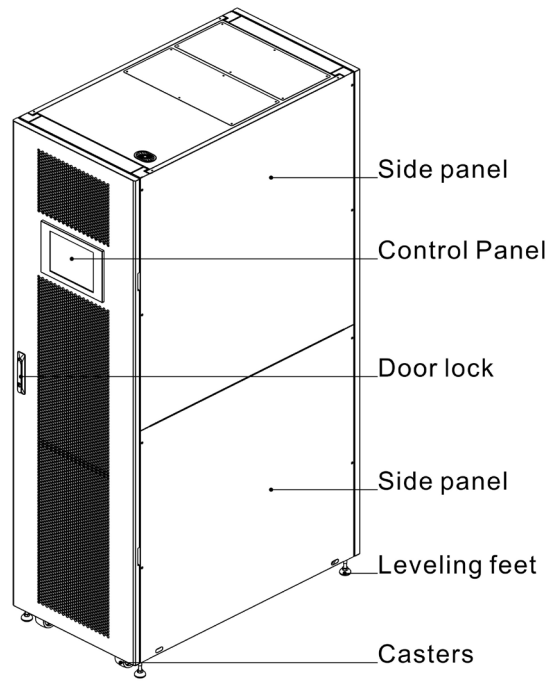

Figure 2-7 Exterior

Mechanical Data

Dimensions			
UPS cabinet	Width	Depth	Height
M90U-80 & 140	23.6"	43.3"	79.1"

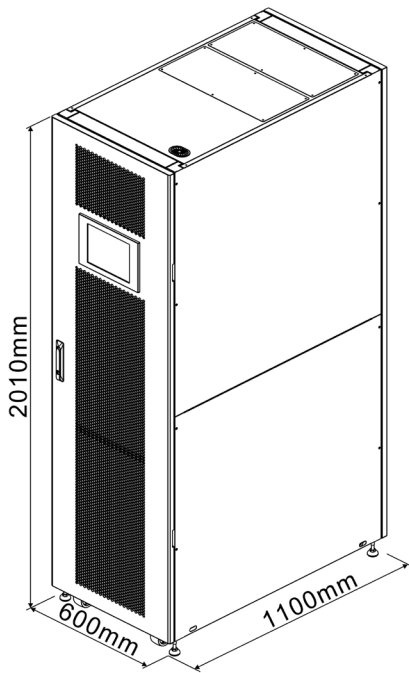
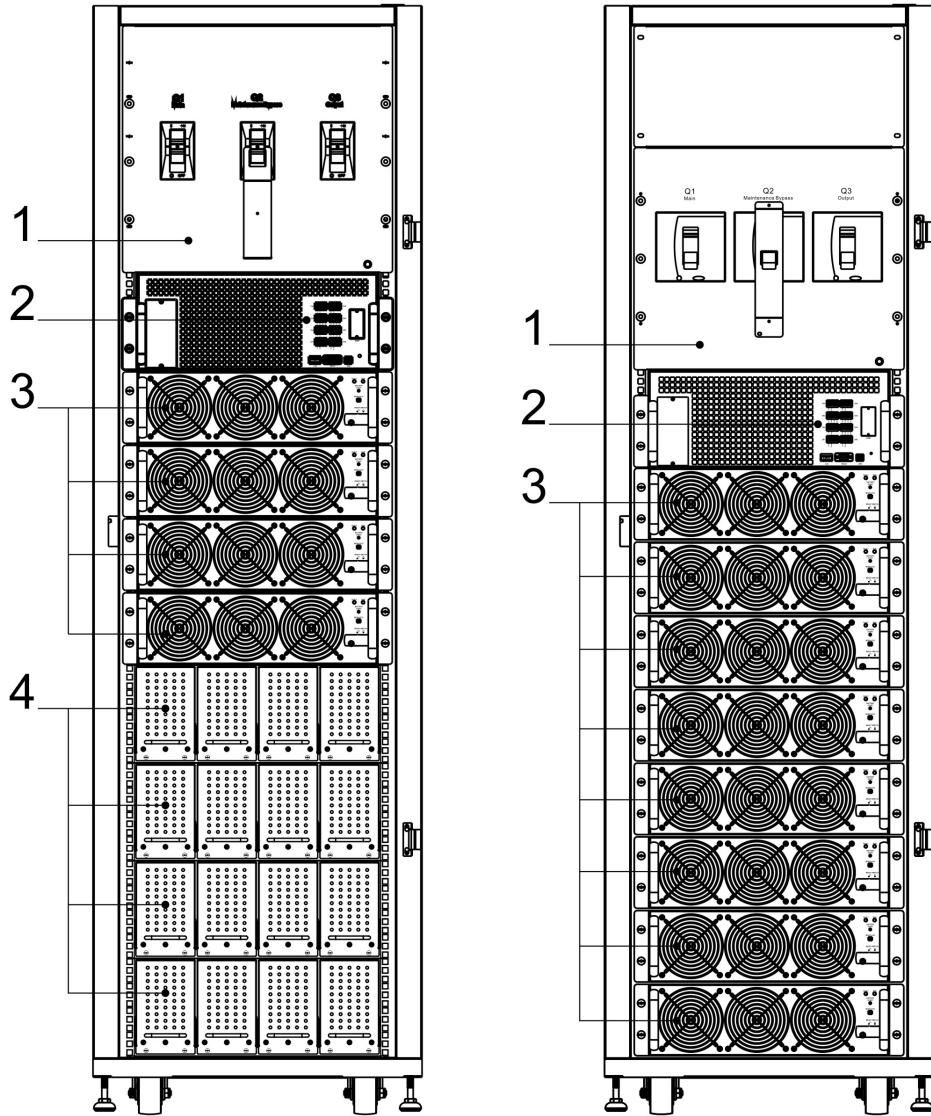

Figure 2-8 Dimensions

2.6.2 Front View

Unlock and open the front door and you will see the Input Breaker (Q1), Maintenance Breaker (Q2), Output Breaker (Q3), STS Module, Power Module slots and Battery Module slots (Battery Module for M90U-80 only).



M90U-80

M90U-140

- 1. Input/Output/Maintenance Breaker
 - 2. STS Module
 - 3. Power Modules
 - 4. Battery Modules
- Figure 2-9 Front View

2.6.3 Rear View

Unlock and open the rear door and you will see the UPS rear panel. There is a battery breaker for internal batteries (M90U-80 only) and wiring terminal blocks.

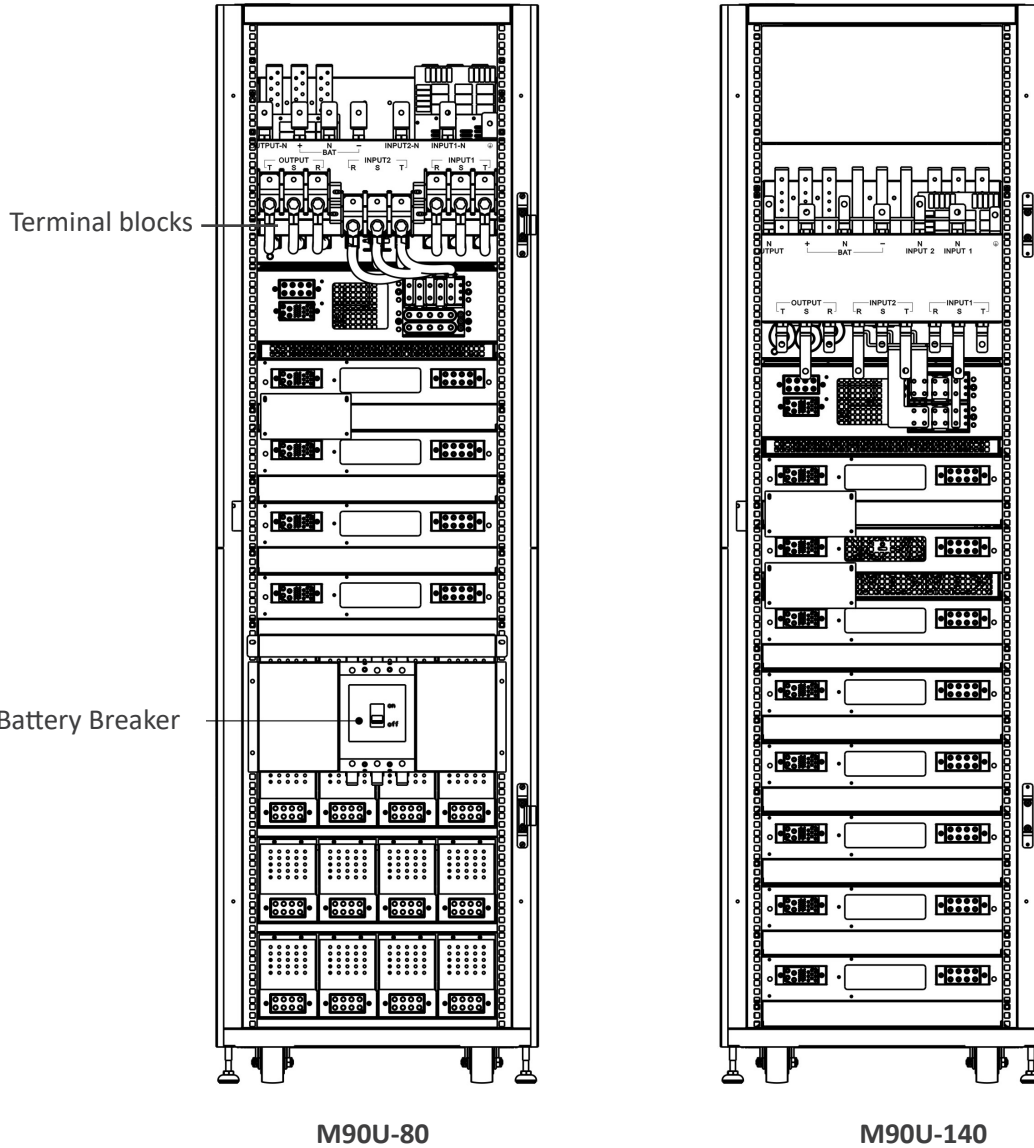

Figure 2-10 Rear View

2.7 Internal Mechanisms

2.7.1 Breakers

After opening the front door, there are three breakers, Input Breaker (Q1), Maintenance Breaker (Q2) and Output Breaker (Q3).

For the M90U-80, there is a battery breaker for internal battery modules located on the rear.

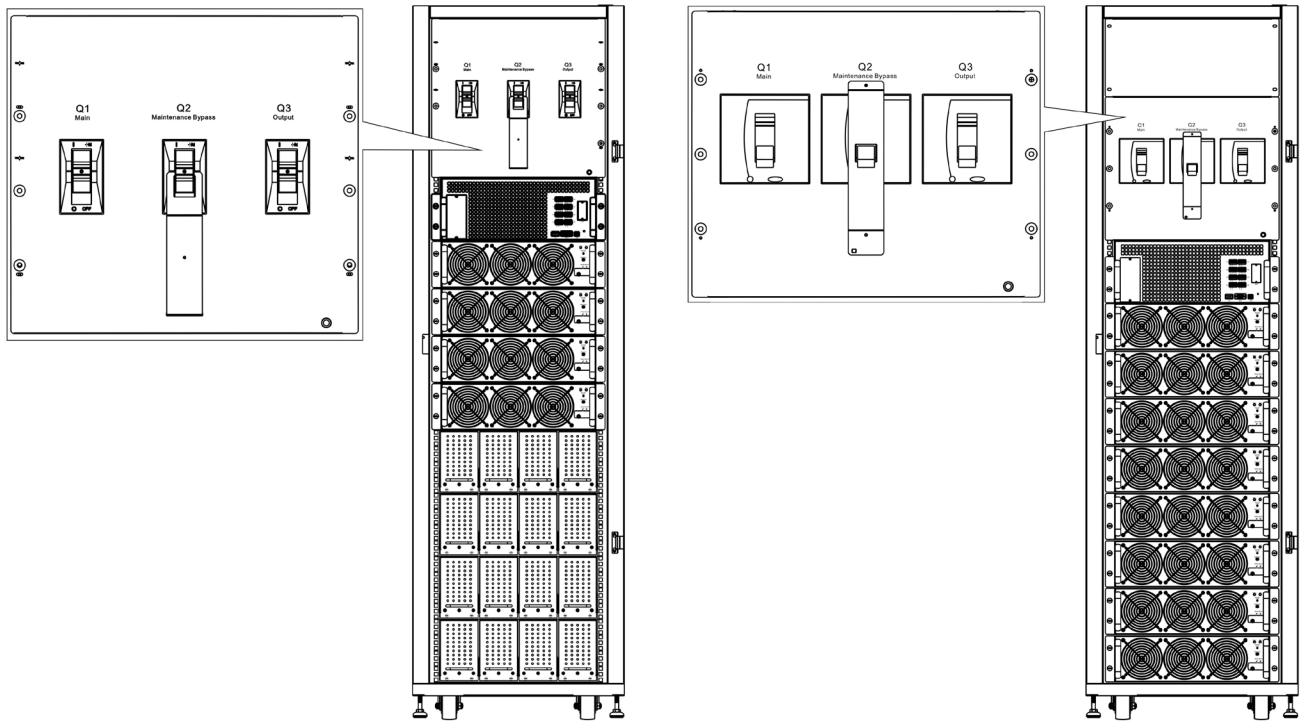

M90U-80

M90U-140

Figure 2-11 Front Breakers

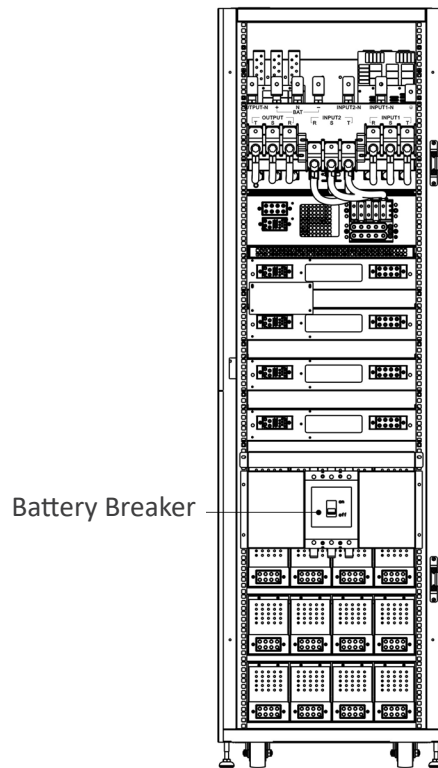

M90U-80

Figure 2-12 Rear Breaker

2.7.2 Wiring Terminal Blocks

Open the UPS's back doors and you will see the wiring terminal block. For UPS cabinet wiring, please refer to Figure 2-13.

No.	Item	Function	Description
1	Output Block	Connects the critical loads	Includes T, S, R and Neutral terminals.
2	Bypass Input Block	Connects bypass AC source	Includes T, S, R and Neutral terminals.
3	Main Input Block	Connects main AC source	Includes T, S, R and Neutral terminals.
4	For UPS Grounding	For UPS grounding	Includes grounding terminal.
5	Battery Input Block	Connects an external battery cabinet	Includes: Positive (+), Negative (-) and Neutral (N) terminals.

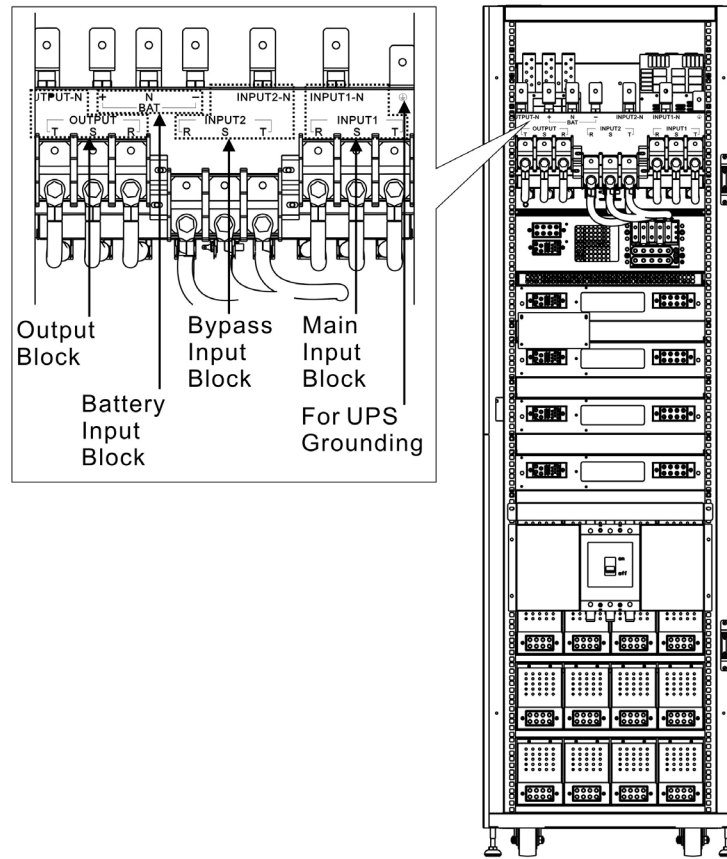

Figure 2-14 M90U-80 Terminal Blocks

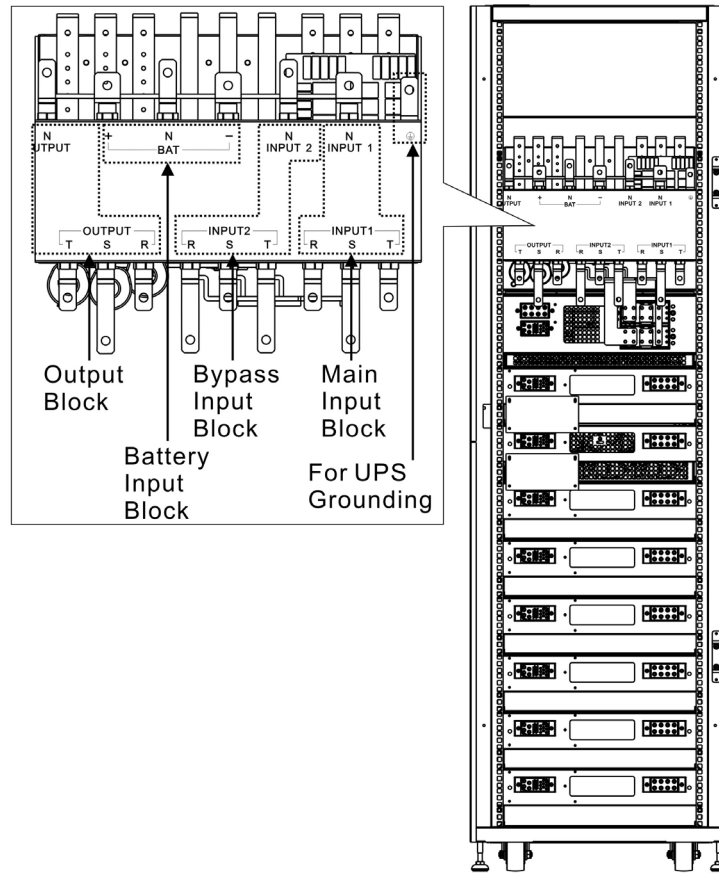

Figure 2-15 M90U-140 Terminal Blocks

2.8 Control Panel

2.8.1 LCD Display

Through the graphic LCD display, the user can easily view the operational mode of UPS. In addition, the measurement, parameters, versions of firmware and warnings can be browsed in the friendly interface. For detailed information, please refer to Chapter 4.

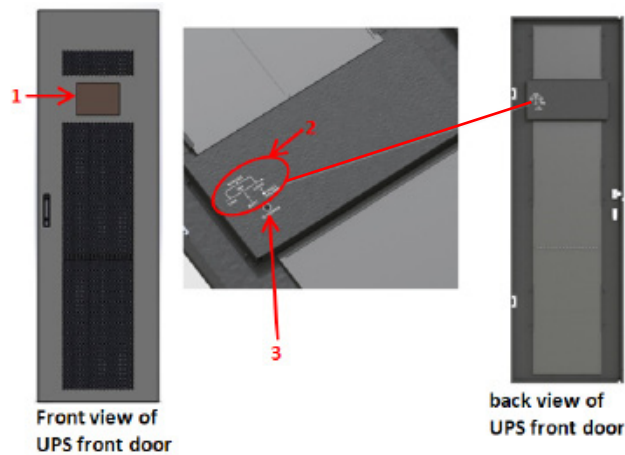

Figure 2-16 Control Panel

2.8.2 LED Indicators

LED	Color	Status	Definition
LINE	Green	On	Input source is normal.
		Flashing	Input source is abnormal.
		Off	No input source
BYPASS	Yellow	On	Load on Bypass.
		Flashing	Input source is abnormal.
		Off	Bypass not operating.
LOAD	Green	On	There is power output for the load.
		Off	There is no power output for the load.
INV BATTERY	Green Red	On	Load on inverters.
		Off	Inverters not operating.
		On	Load on Battery.
FAULT/ ALARM	Red	Flashing	Low battery
		Off	UPS is normal and battery is charging.
		On	UPS fault.

2.8.3 Control Key

Turn on or turn off the UPS.

2.9 Introduction of Modules

The design of STS Module, Power Module and Battery Module make maintenance and replacement quick and easy. The modular and hot-swappable design of the power and battery modules makes a highly cost-effective solution to meet your power requirement. The number of power or battery modules installed in the UPS can be based on the initial needs. Once the power or runtime requirement increases, you can easily install more power or battery modules without interrupting the operation of the system.

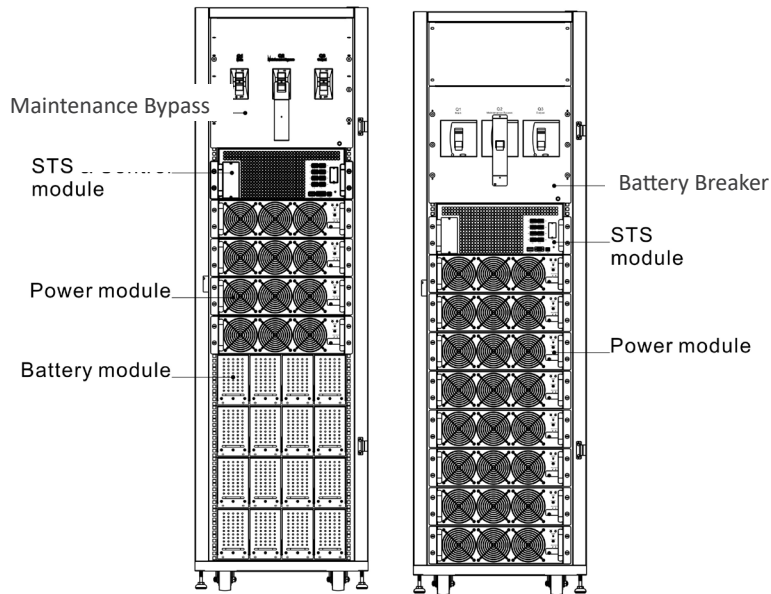

Figure 2-17 Front View of Module

2.9.1 STS Module

The STS Module is installed before leaving factory. It provides the bypass power when UPS is in Bypass Mode. In addition to offering bypass power, it includes some communication interfaces. For detailed information, please refer to Chapter 5.

No.	Item	Description
1	Extra Comm. Slot	This slot can insert an optional M90U-Comm card which can enhance the communication capability of UPS system. It can provide another SNMP slot, programmable dry contact ports and external temperature probe connection.
2	LCD Port	This port connects to Control Panel with a factory installed cable.
3	RS232 port	Local communication interface.
4	USB port	Local communication interface.
5	SNMP Slot	This slot can work with optional cards, SNMP, relay or Modbus card.
6	Dry contact ports	CN1 ~ CN8. For detailed information, please refer to Chapter 5.

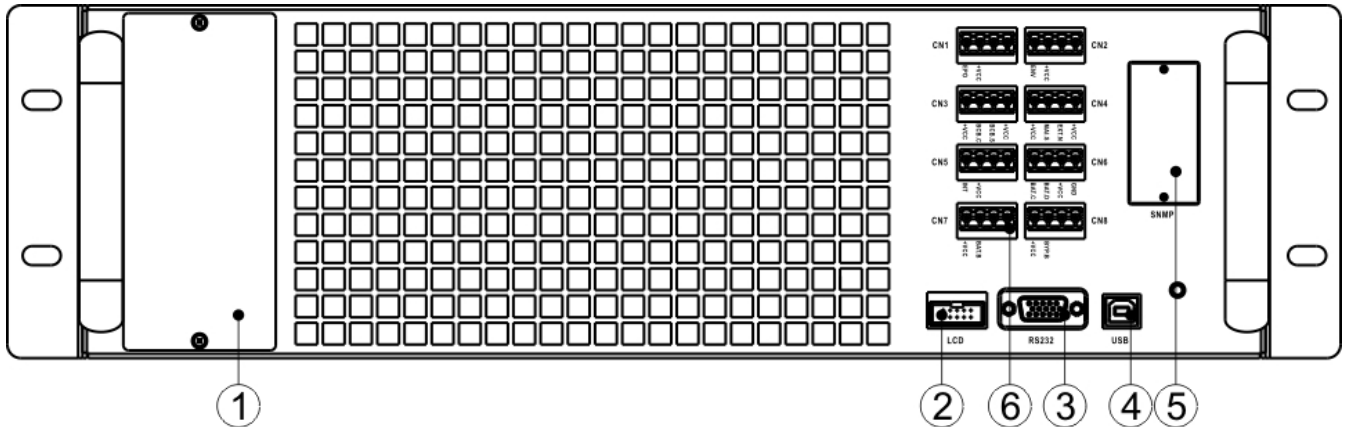

Figure 2-18 STS Module

Power Module

Each Power Module is shipped with its own packaging. It must be installed during the UPS system installation. The capacity of each Power Module is 20kVA/20kW or 15kVA/15kW. It includes a power factor correction rectifier, a battery charger, an inverter and control circuit.

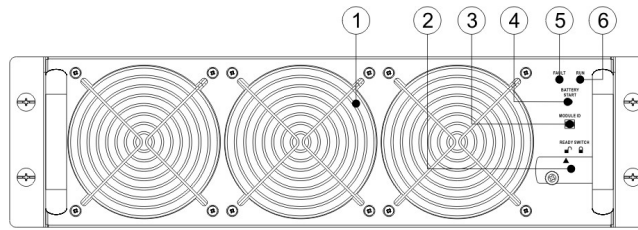

Figure 2-19 M90U-PWRM

No.	Item	Description	
1	Fan	The Power Module uses forced convection cooling by these fans. Cooling air enters the module through ventilation grills and exhalation exhausts through grills located at the rear of the module. Please do not block the ventilation area.	
2	Ready Switch	Unlock it before removing the Power Module. Lock it when the Power Module is installed.	
3	DIP Switches	There are three DIP switches for Power Module address setting. Each Power Module ID MUST be exclusive.	
4	Battery Start Button	When AC input is not available, use this button to start battery power for UPS.	
5	FAULT LED	ON	The Power Module is in fault condition or the Ready Switch is unlocked.
		ON/OFF 0.5 sec	The Power Module IDs conflict.
		ON/OFF 0.15 sec	The static switch is not found.
6	RUN LED	ON	The Power Module operates as a slave module.
		ON/OFF 0.5 sec	The Power Module operates as a master module.
		ON/OFF 0.15 sec	The CAN Bus communication doesn't work.

DIP switch setting and Module Address

Module Address	DIP SWITCH	Module Address	DIP SWITCH
00		01	
02		03	
04		05	
06		07	

Table 2-1 DIP switch setting and Module Address

Power Module ID Assignment

According to the Module Address and the position of SW1 and SW2, the Power Module's ID is assigned. The Module ID is shown in Table 2-2.

These two switches, SW1 & SW2 are mounted in the Parallel board which is located at the back of UPS cabinet. Refer to Figure 2-20.

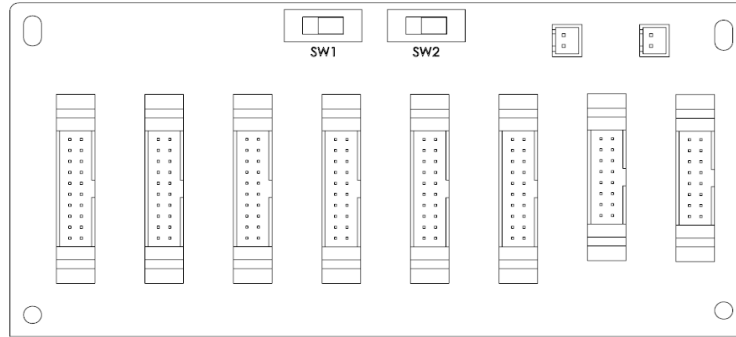

Figure 2-20 Parallel Board

The SW1 and SW2 position have been setup before leaving the factory. It's not necessary to change it.

Module ID Assignment

SW1 & SW2	Module Address	Module ID	SW1 & SW2	Module Address	Module ID
	0	0		0	9
	1	1		1	10
	2	2		2	11
	3	3		3	12
	4	4		4	13
	5	5		5	14
	6	6		6	15
	7	7		7	7

Table 2-2 Module ID Assignment

2.9.3 M90U-80 Battery Module (does not apply to M90U-140)

The Battery Module are shipped seperately. The batteries inside the module are installed at the factory. M90U-80 Battery Modules contains 10 pcs of 12V/580W batteries. Internal batteries are installed by a factory technician, or end user.

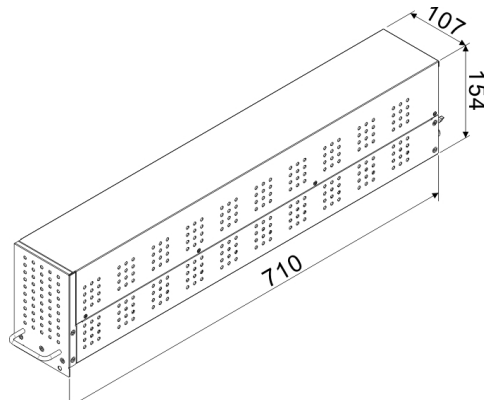

Figure 2-21 M90U-80 Battery Module

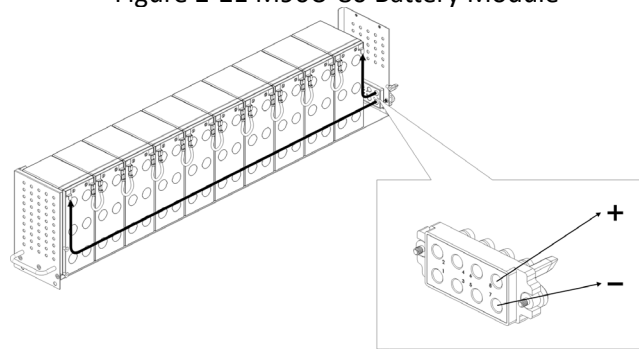

Figure 2-22 M90U-80 Battery Module

2.10 Power Cable

Warning

Please follow the local wiring regulations. Follow environmental conditions and refer to IEC60950-1.

Table 2.10.1

Model	15KVA	20KVA	30KVA	40KVA	45KVA	60KVA	75KVA
Current (A)	45	60.1	90	120.2	135	180.3	225
Power cable (mm ²)	16	16	50	50	95	95	150
Fixation torque force (lb-in)	88.3	88.3	88.3	88.3	88.3	88.3	88.3
Model	80KVA	90KVA	100KVA	105KVA	120KVA	140KVA	
Current (A)	240.4	270	300.5	315	360.6	420.7	
Power cable (mm ²)	150	240	240	95 x 2	95 x 2	120 x 2	
Fixation torque force (lb-in)	88.3	100	100	100	100	100	

Power cable size based on THHN 90° copper wire

Notice: Installer has to consider the max. current and wiring gauge when considering future extension.

Warning:

1. When Load is less than 20KVA, at least one layers of battery modules (4 modules) have to be installed.
2. When Load is between 20KVA and 40KVA, at least two layers of battery modules (8 modules) have to be installed.
3. When Load is between 40KVA and 60KVA, at least three four of battery modules (12 modules) have to be installed.
4. When Load is between 60KVA and 80KVA, at least four of battery modules (16 modules) have to be installed.
5. The same type of battery has to be used, if the battery is in parallel application.

Table 2.10.2

Model	15KVA	20KVA	30KVA	40KVA	45KVA	60KVA	75KVA
Current (A)	73.5	98	147	196	220.5	294	367.2
Power cable (mm ²)	25	25	95	95	150	150	240
Fixation torque force (lb-in)	100	100	100	100	100	100	100
Model	80KVA	90KVA	100KVA	105KVA	120KVA	140KVA	
Current (A)	392	441	490	514.5	588	686	
Power cable (mm ²)	240	120 x 2	120 x 2	150 x 2	150 x 2	185 x 2	
Fixation torque force (lb-in)	100	100	100	100	100	100	

Power cable size based on THHN 90° copper wire

2.11 Wiring

WARNING:

- Before connecting any wire, make sure the AC input and battery power is completely turned off.
- Make sure the breakers, Input Breaker (Q1), Maintenance Breaker (Q2), Output Breaker (Q3) and battery breaker are all in the OFF position.

2.11.1 Installation Drawing

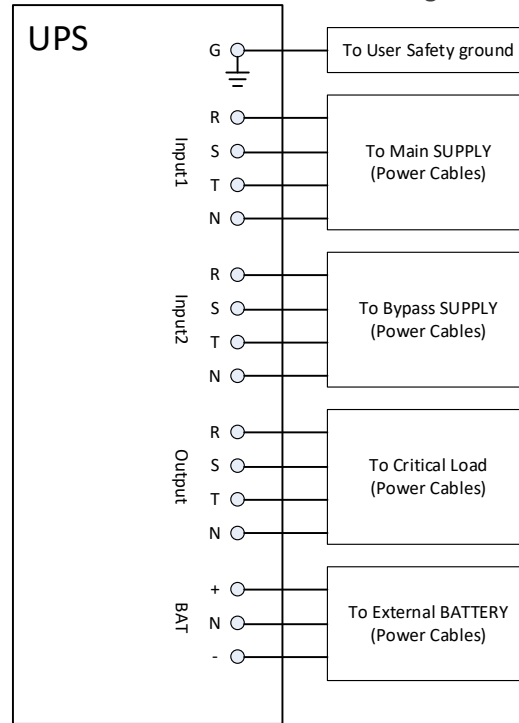

Figure 2-23 UPS Cabinet Wiring

2.11.2 AC source connection

For Single input application, connect Input1 to the AC power source. 3 jumper wires connect Input1 and Input2 (factory default).

For Dual input application, connect input1 to the Main AC power source and connect input2 to the Bypass power source.

The sequence of three phase, R, S and T must be connected accordingly. The wrong sequence will alarm a warning when the UPS is powered.

The N must be connected. A warning message will be indicated if the N is not connected.

There is no Breaker between Input2 and STS Module, the STS module is powered up when Input2 is powered, though the Q1 Breaker is OFF.

2.11.3 External Battery Cabinet Connection

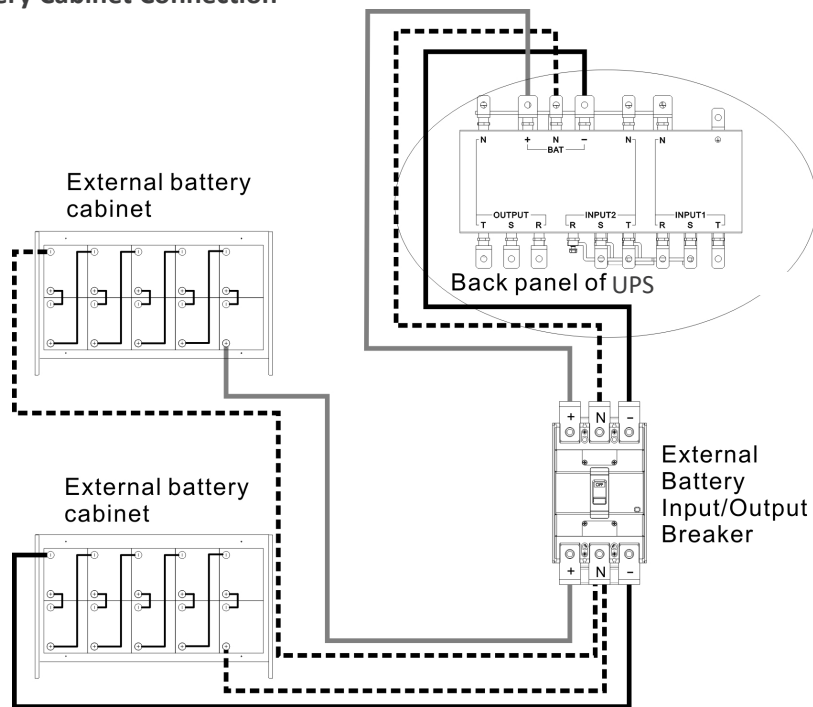

Figure 2-24 External Battery Cabinet Wiring

After the battery is completely installed, be sure to set up nominal battery voltage, battery capacity and maximum charging current in LCD setting. Otherwise, if battery setting is different from actual installation, the UPS will keep warning. Please refer to section 4.2.6.3 and Table 4-9 for the details.

2.12 Power Module Installation

The weight of Power Module is over 70lbs.

2.12.1 Insert the Power Module

1. Adjust the DIP switch positions to set the different Module Address. Refer to Table 2-1.

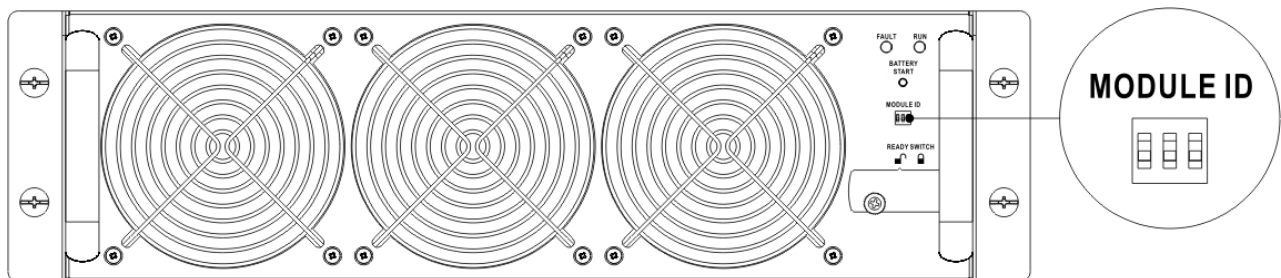

2. Place the ready switch at the front panel of the module to the “” position (i.e., in unready state).
3. Insert the Power Module into an unoccupied slot by using two persons.

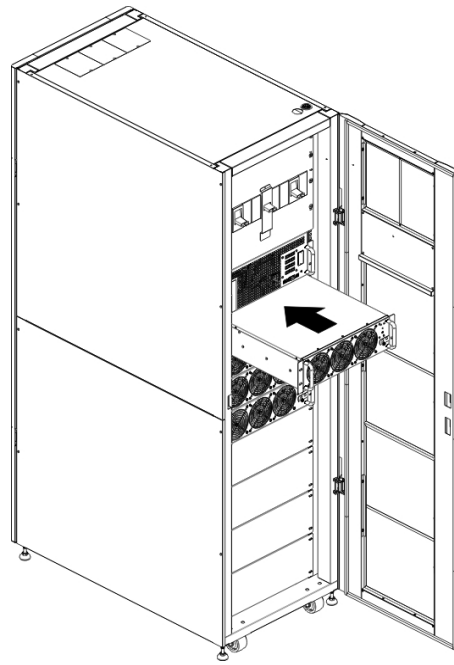

4. Secure the Power Module to the cabinet by inserting the screws at the front panel of the Power Module.

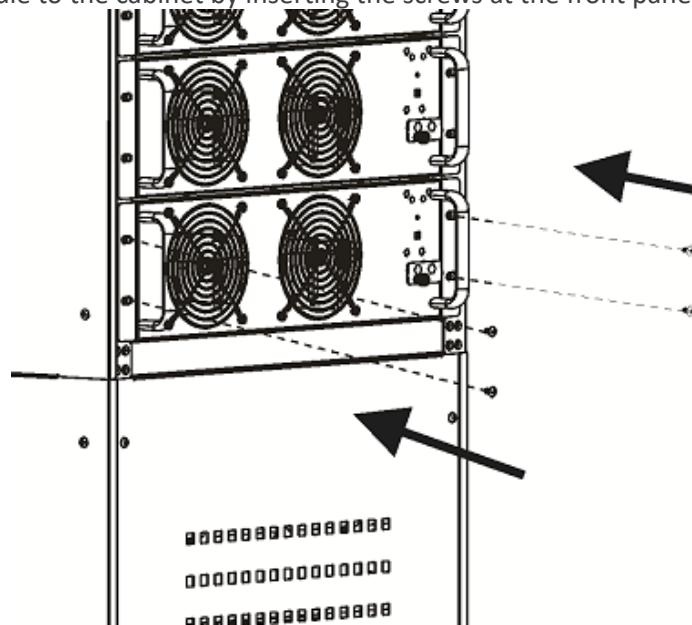

5. Move the ready switch to the "🔒" position (i.e., in ready state).

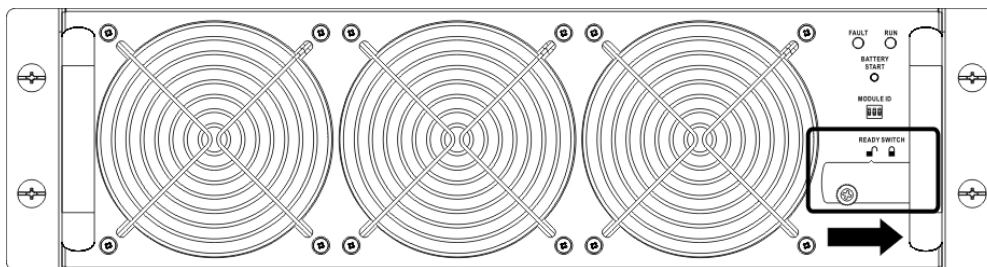

Remove the Power Module

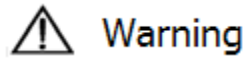

- Before removing any Power Module, make sure the remaining Power Modules can support the critical loads.
 - At least one Power Module **MUST** stay in the UPS cabinet unless the UPS system is operating in Maintenance Bypass Mode.
1. Turn the ready switch to the “” position.
 2. The Power Module **FAULT LED (RED)** indicator is lit to show the Power Module output is off and disconnected from UPS system.

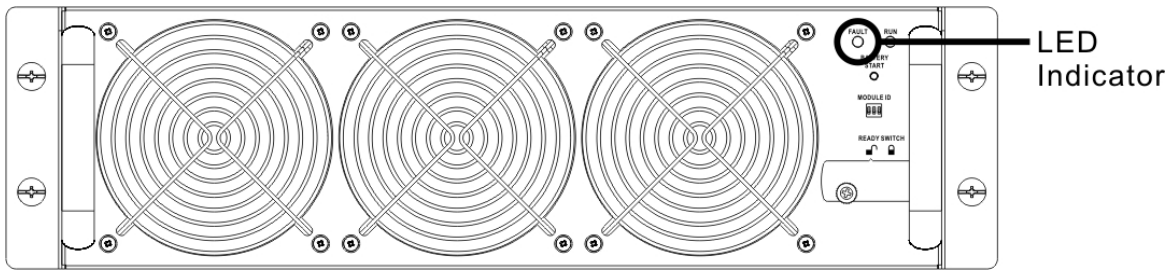

3. Use a screwdriver to remove the four screws.
4. Remove the Power Module from its slot.

2.13 Battery Module Installation

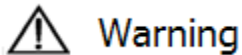

- The weight of Battery Module is heavy so at least two persons are required for handling.
- Before performing the Battery Module installation/ replacement, make sure the Battery Breaker is in the OFF position.

2.13.1 Insert the Battery Module (M90U-80 Cabinet only)

1. Open the UPS's front door and remove the panel of battery module shelf

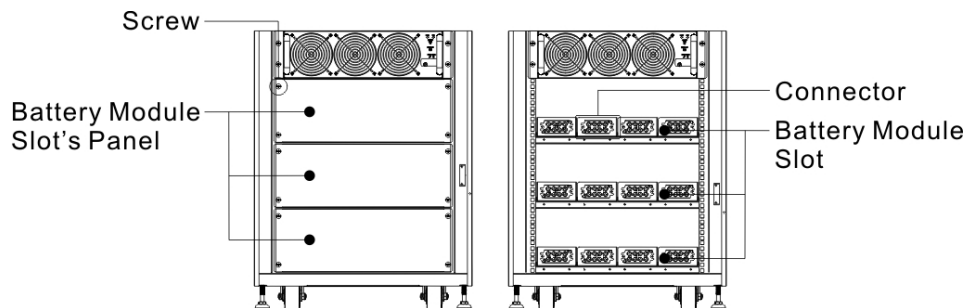

2. There are 4 rails for inserting the Battery Modules in the same shelf. Four Battery Modules **MUST** be installed to form a set of Battery.

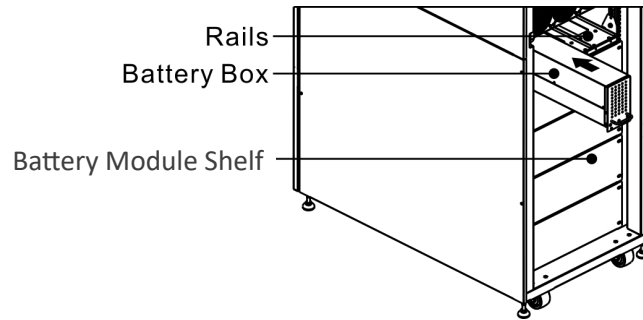

3. Regarding the maximum load of power modules, please refer to section 2.10.2 for the minimum number of battery modules.
4. Secure the Battery Module to the cabinet by fixing the screws of the Battery Module.

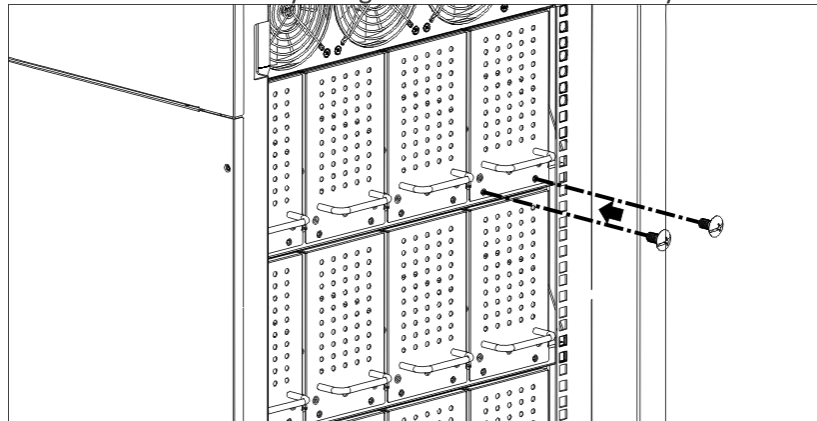

3. Operation Mode and UPS Operation

3.1 Block Diagram of UPS

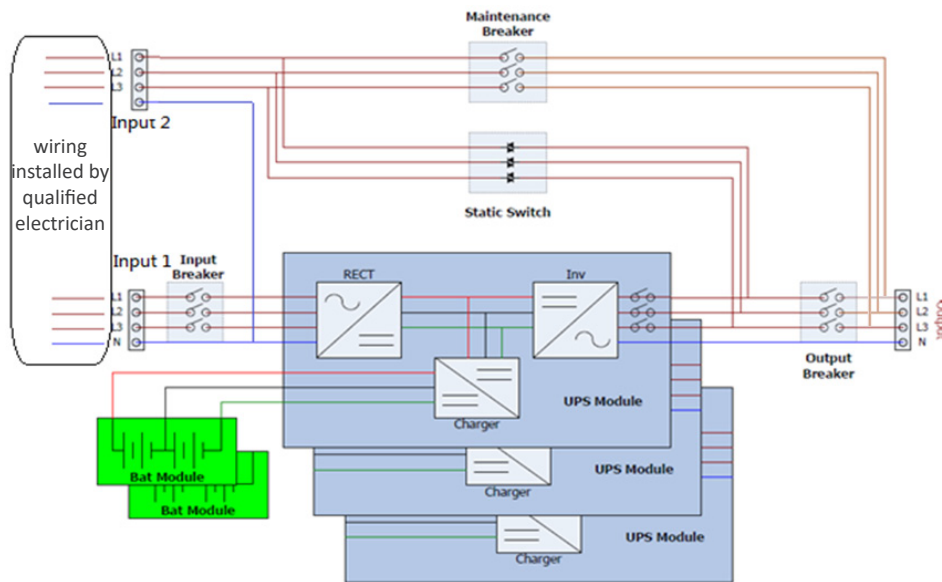

Figure 3-1: Wiring diagram for dual inputs

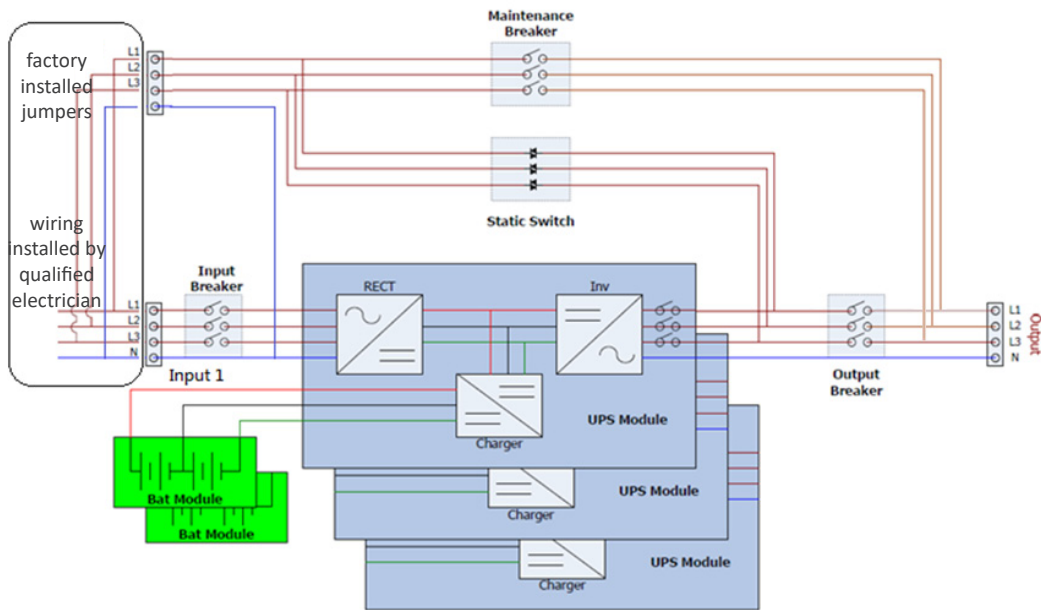

Figure 3-2: Wiring diagram for single inputs

3.2 Operation Mode

This modular UPS is a three-phase, four wire on-line, double-conversion and reverse-transfer UPS that permits operation in the following modes:

- Standby Mode
- Line Mode
- Battery Mode
- Bypass Mode
- ECO Mode
- Shutdown Mode
- Maintenance Bypass Mode (manual bypass)

Standby Mode

Upon connecting to utility input power, the UPS is in Standby mode before UPS is turned on (if BYPASS enable setting is Disabled), and charger function will be active when the battery is present. The load is not powered under this mode.

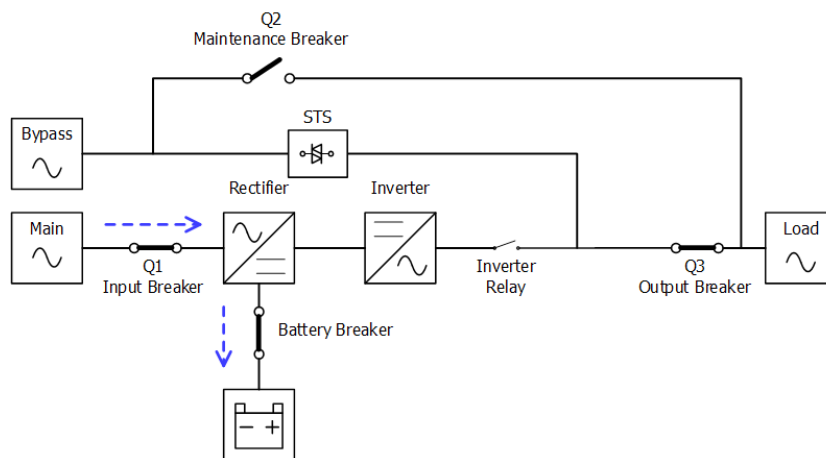

Figure 3-3 : Standby Mode Diagram

3.2.2 Line Mode

In Line Mode, the rectifier derives power from the utility power and supplies DC power to the inverter and the charger charges the battery. The inverter filters the DC power and converts it into pure and stable AC power to the load.

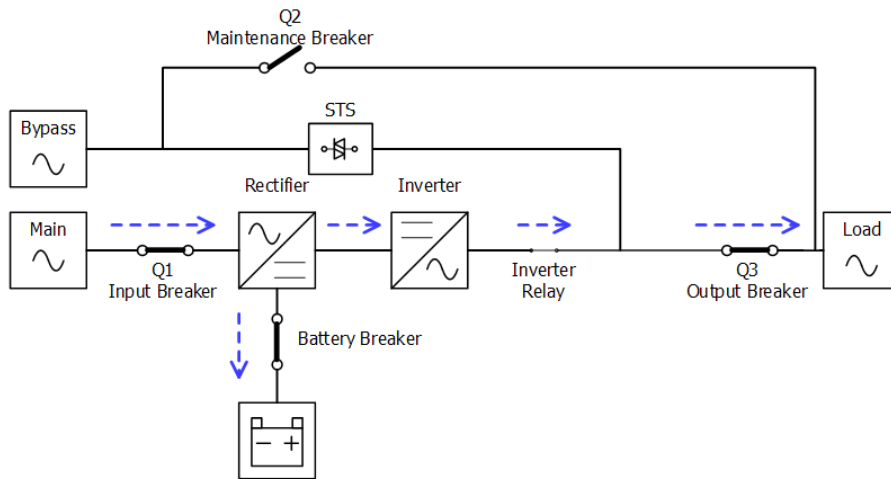

Figure 3-4 : Line Mode Diagram

3.2.3 Battery Mode

The UPS automatically transfers to Battery mode if the utility power fails. There is no interruption in power to the critical load upon failure.

In battery mode, the rectifier derives power from the battery and supplies DC power to the inverter. The inverter filters the DC power and converts it into pure and stable AC power to the load.

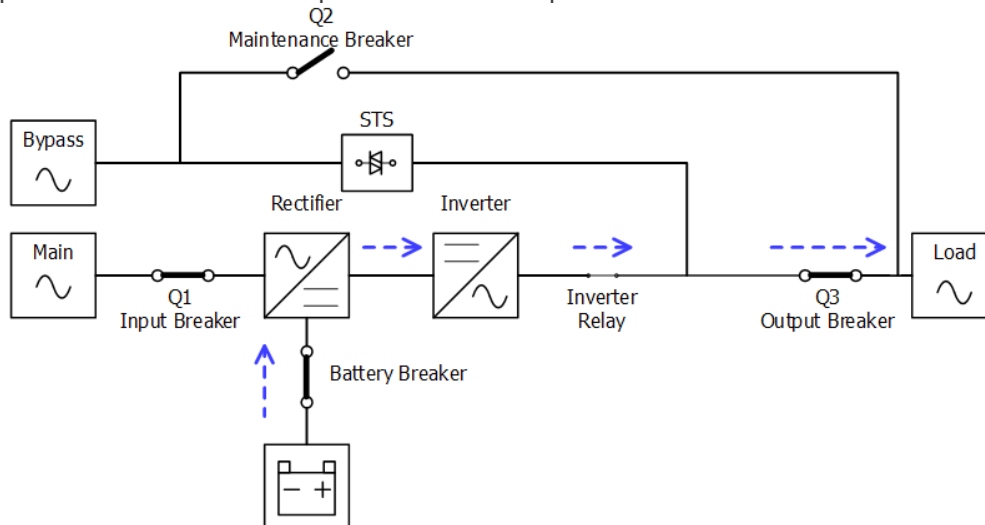

Figure 3-5 : Battery Mode Diagram

3.2.4 Bypass Mode

Upon connecting to utility input power, the UPS is in Bypass mode before UPS is turned on (if BYPASS enable setting is Enabled), and charger function will be active when battery is present.

After UPS has been turned on, if the UPS encounters abnormal situations (over-temperature, overload ..., etc.), the static transfer switch will transfer the load from the inverter to the bypass source with no interruption. If the transfer is caused by a recoverable reason, the UPS will turn back to line mode when abnormal situation is solved.

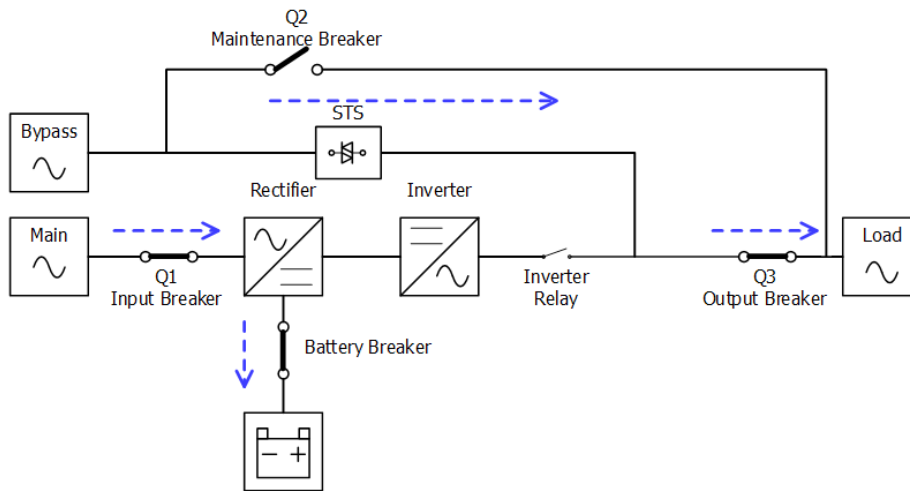

Figure 3-6 : Bypass Mode Diagram

3.2.5 ECO Mode

The ECO Mode is enabled through the setting menu of LCD panel. In ECO mode, the load is powered by bypass when the bypass voltage and frequency are within the acceptable ranges. If the bypass is out of range, the UPS will transfer the power source of load from bypass to inverter. In order to shorten the transfer time, the rectifier and inverter are working when the UPS is in ECO mode.

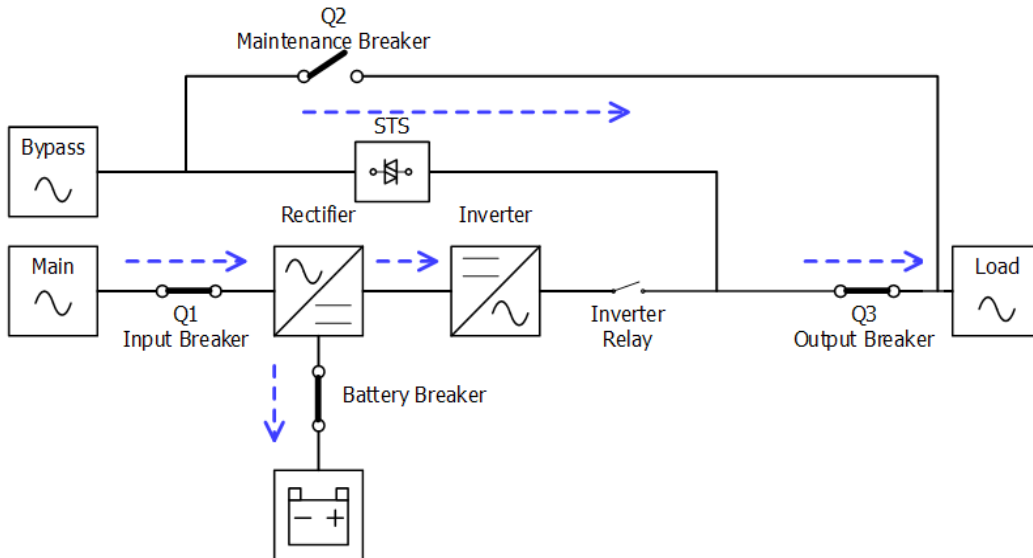

Figure 3-7 : ECO Mode Diagram

3.2.6 Shutdown Mode

When the UPS is in the off state and the utility power source is absent, the UPS will enter into shutdown mode. Or when the UPS has discharged the battery to the cut-off level, the UPS will enter into shutdown mode as well. When the UPS enters this mode, it is going to shut off the control power of UPS. The rectifier, charger and inverter are all in off state.

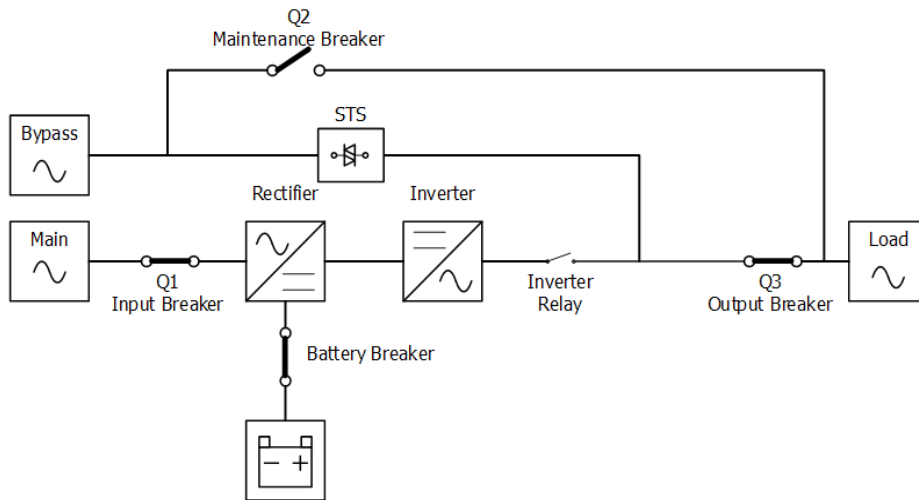

Figure 3-8 : Shutdown Mode Diagram

3.2.7 Maintenance bypass Mode

A manual bypass switch is available to ensure continuity of supply to the critical load when the UPS becomes unavailable e.g. during a maintenance procedure. Before entering the maintenance bypass mode, make sure the bypass power source is normal

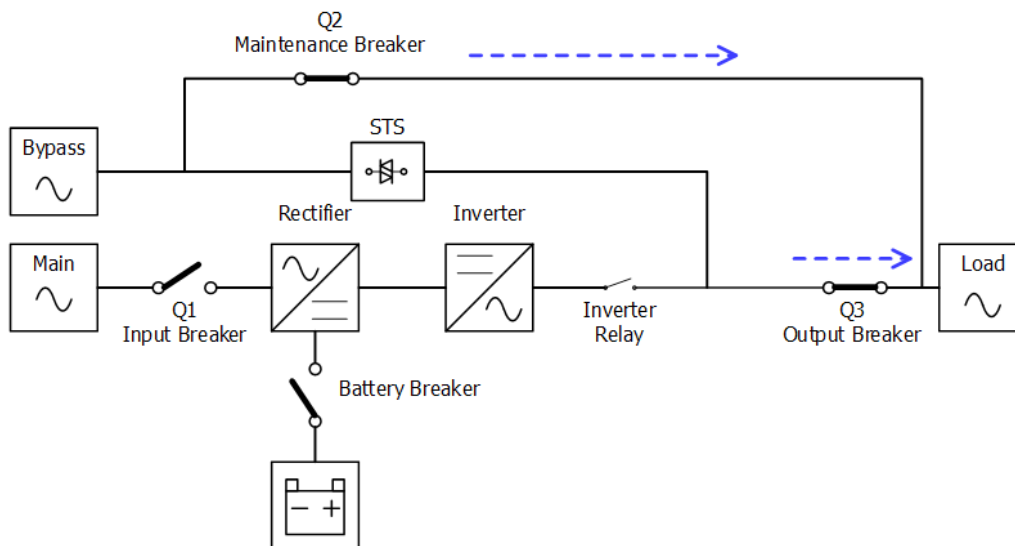

Figure 3-9 : Maintenance Bypass Mode Diagram

3.3 UPS Operation

- Do not start the UPS until the installation is complete.
- Make sure the wiring is correct and the power cables are properly connected.
- Make sure the Power Modules' addresses have been configured. Refer to the Power Module ID Assistance section.
- Make sure the ready switch on the Power Module has been moved to the "Locked" position.
- Make sure all the breakers are switched OFF.

3.3.1 AC Startup

Follow this procedure when turning on the UPS from a fully powered-down condition.

The operating procedures are as follows:

Step 1: Refer to “Chapter 2 Installation” to connect the power cables and install the Power Modules and the battery required for the UPS system.

Step 2: Switch ON the battery breaker.

Step 3: Switch ON the external power switch in distribution panel to power the UPS. The STS module is powered up and the LCD panel is displayed.

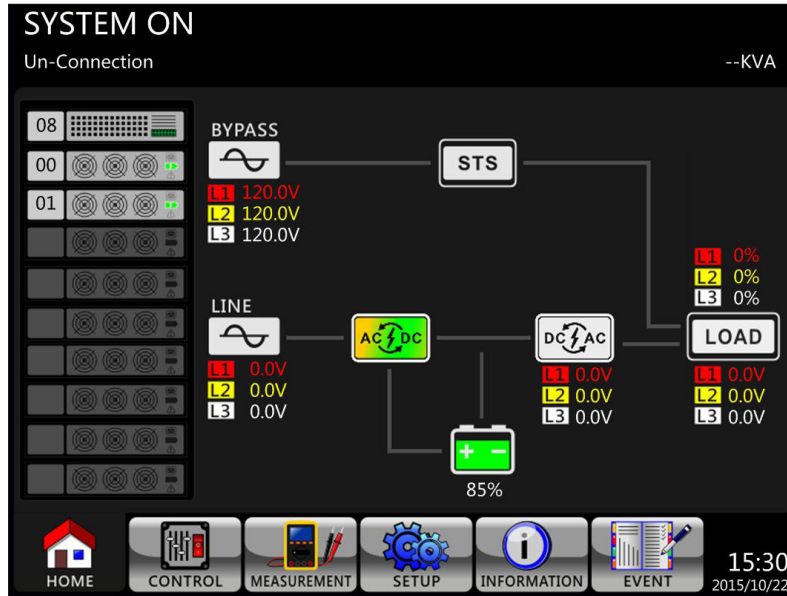

Step 4: Switch ON the input breaker (Q1). The UPS will enter into Standby Mode, if the setting of Bypass mode is disabled.

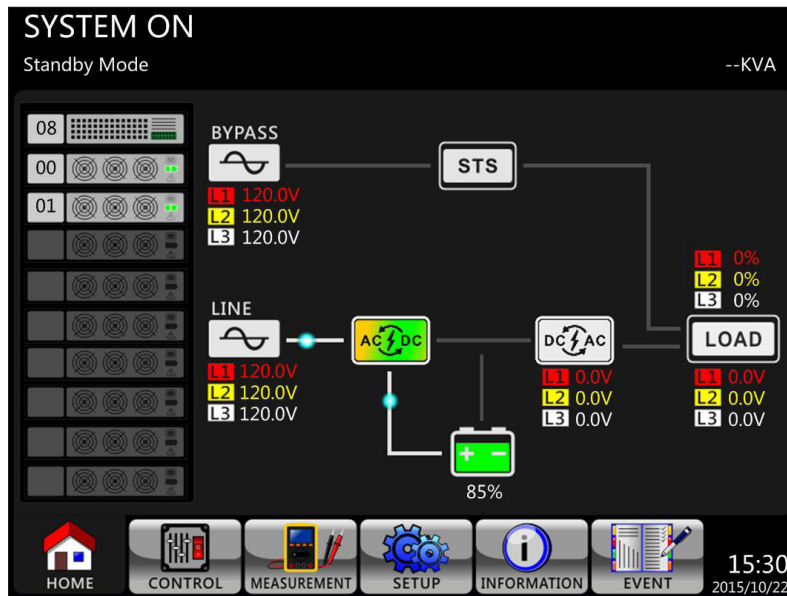

Or the UPS will enter into Bypass Mode, if the setting of Bypass mode is enabled.

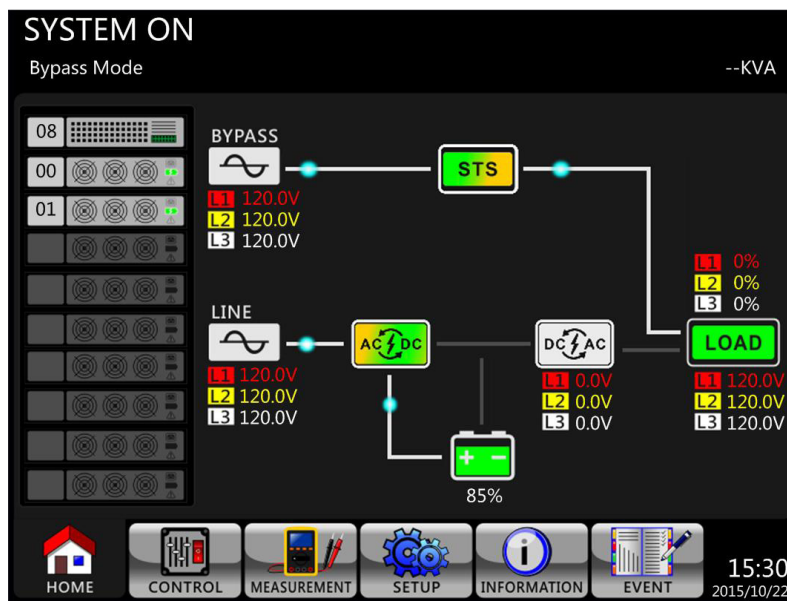

Step 5: Make sure there are no warning or fault events happening. If there is, please refer to Chapter 6 Troubleshooting to solve it.

Step 6: Press Power ON/OFF button for two seconds to enter into Line Mode as shown below.

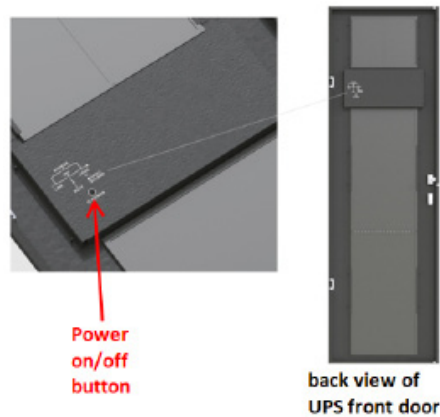

The UPS will run a self-test and transfer to line mode when all power modules are ready.

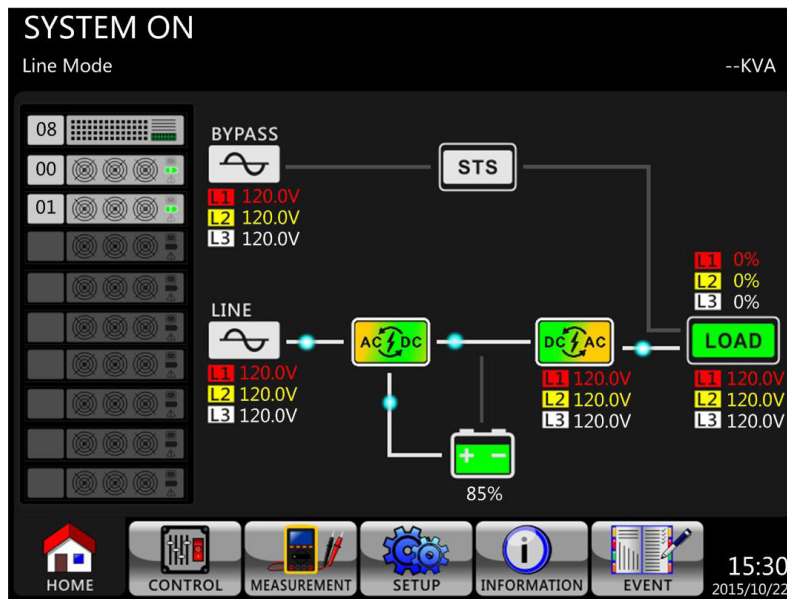

Step 7: Switch ON the output breaker (Q3). AC startup procedure is complete.

3.3.2 Cold Start Startup

Step 1: Switch ON the battery Breaker.

Step 2: Press the “Battery Start” button on any one of Power Modules to start up the control power of all Power modules and STS as shown below.

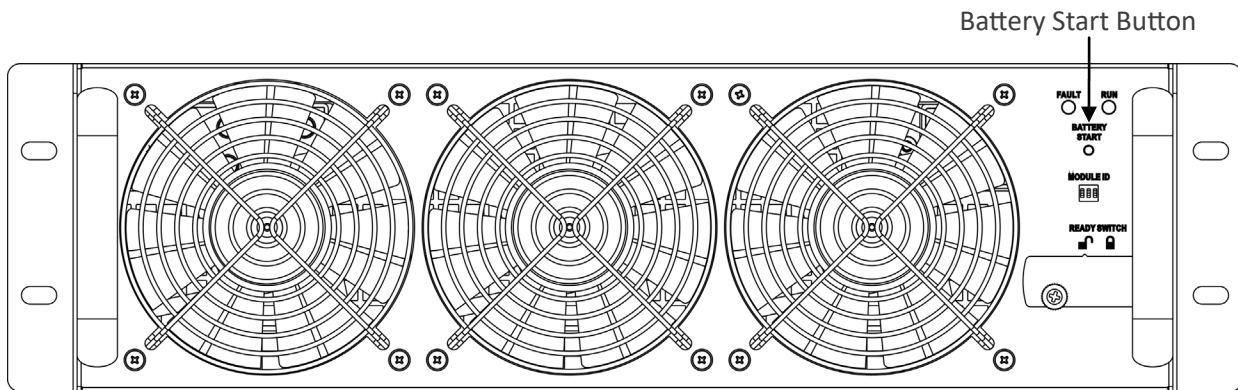

Step 3: After pressing the “Battery Start” button, UPS will enter into Standby mode. Refer to the diagram below for LCD display.

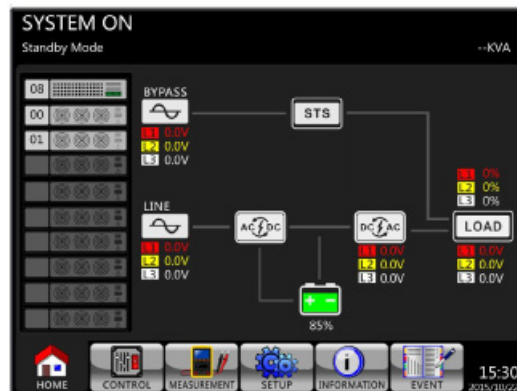

Step 4: Before UPS enters into shutdown mode, please press "Power On/Off" button for 2 seconds immediately as shown in the diagram below.

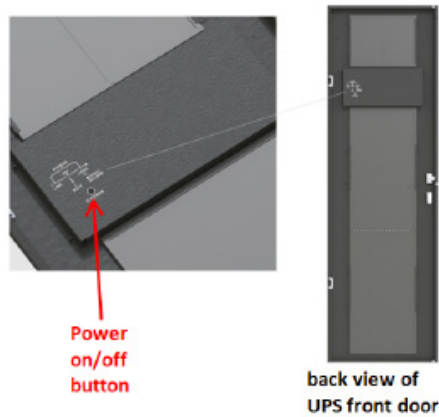

Step 5: Then, UPS will enter Battery Mode as shown in the diagram below.

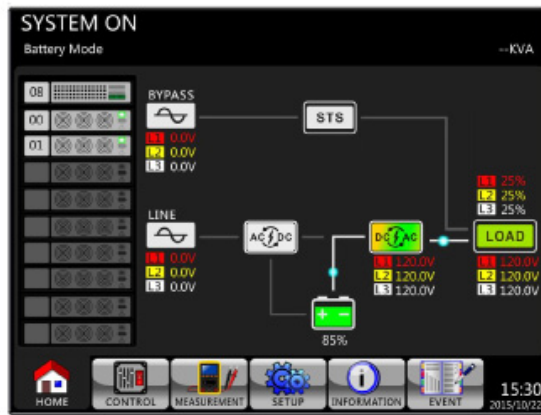

Step 6: Switch ON the output breaker (Q3). Cold start startup procedure is complete.

3.3.3 Maintenance Bypass Operation

Follow the instruction to transfer to Maintenance Bypass and UPS protection as below.

3.3.3.1 Transfer to maintenance bypass

Step 1: Remove the mechanical lock plate of Maintenance Bypass Breaker.

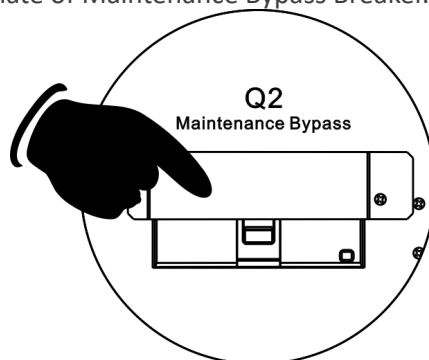

Step 2: Make sure the UPS operates in Bypass mode as shown below.

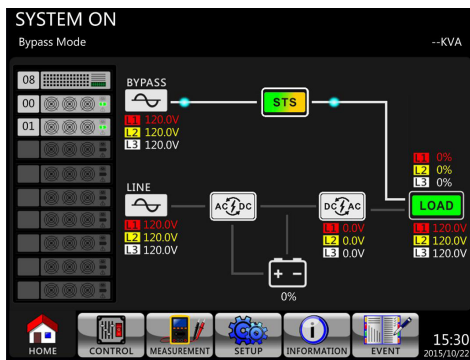

Step 3: Switch ON the Maintenance Bypass Breaker as shown below.

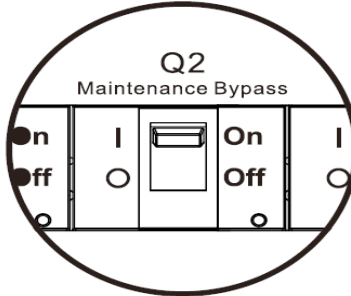

Step 4: Switch OFF the Input Breaker (Q1) as shown below.

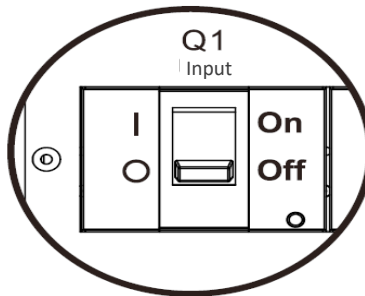

Step 5: It is possible to change the STS module, Power Module and Battery Module.

3.3.3.2 Transfer to UPS Protection

Step 1: Make sure the maintenance is complete. The Power Modules and STS module have been installed well.

Step 2: Switch ON the Main Breaker (Q1) as shown below.

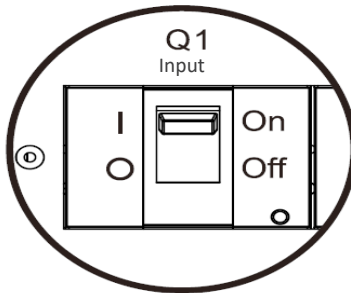

Step 3: Please enter LCD SETUP MENU and choose "SYSTEM" to ensure that the "Bypass mode" is enabled. If the "Bypass mode" is disabled, you have to set it enabled. Then, exit the SETUP menu and check if the UPS is operating in Bypass mode.

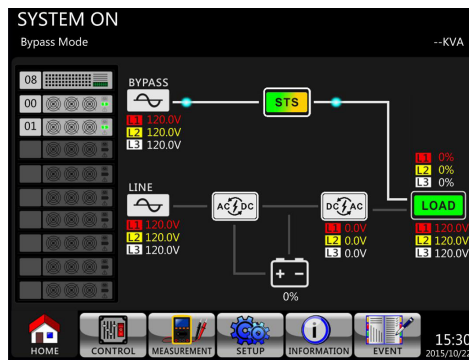

Step 4: Turn off Maintenance Bypass Breaker as shown below.

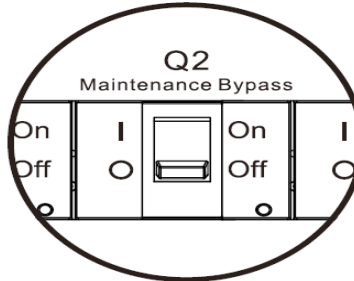

Step 5: Lock back the mechanical lock plate as shown below.

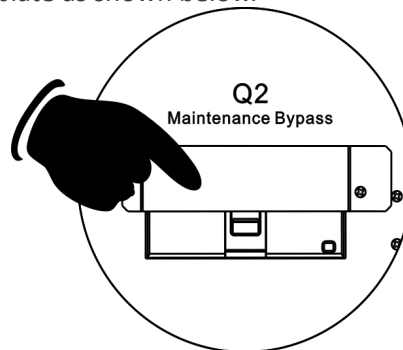

3.3.4 Turn off Operation

3.3.4.1 Bypass Mode/ Standby Mode Turn Off Operation

When the UPS neither is turned on nor turned off, the UPS operates in the Standby Mode or Bypass Mode, depending on the "Bypass Mode" Setting.

The LCD diagrams are shown below.

Bypass Mode Setting is Disabled

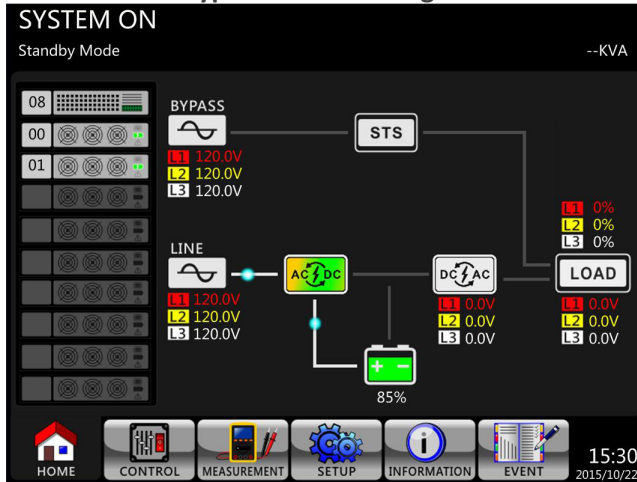

Bypass Mode Setting is Enabled

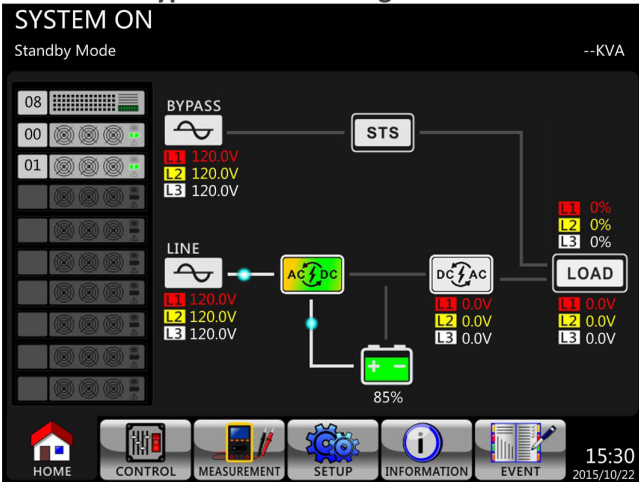

Step 1: Switch OFF the Input Breaker (Q1). The LCD diagrams are shown below.

Bypass Mode Setting is Disabled

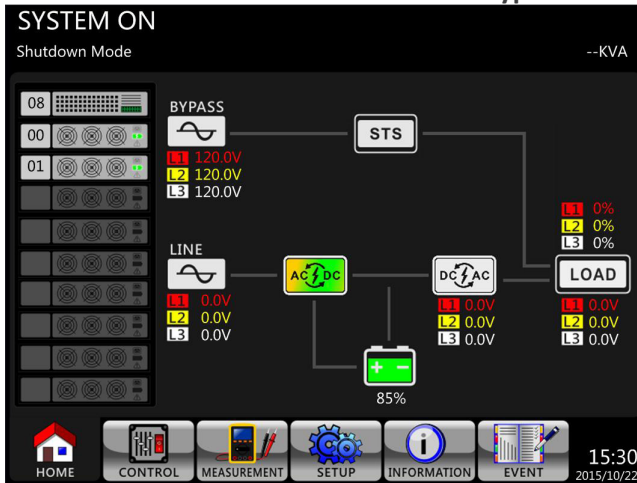

UPS enters Shutdown Mode.

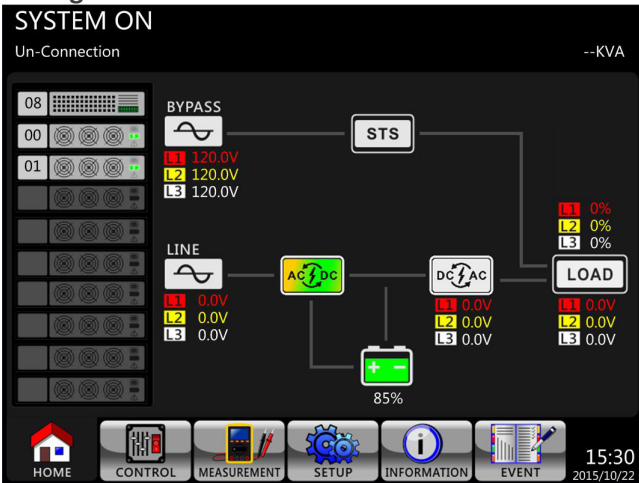

It is normal to have the Un-Connection is shown when Power Modules have shut off their control power.

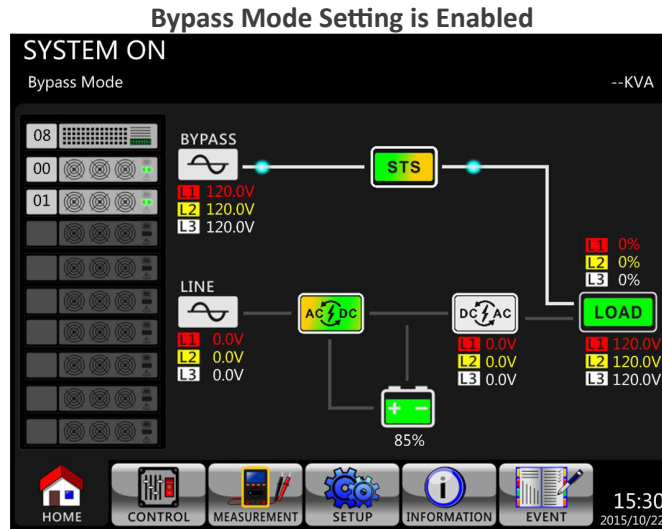

UPS stays in Bypass mode and No AC input is indicated.

Step 2: Switch OFF the external power switch to disconnect the AC power to the UPS. Wait until the LCD is OFF.

Step 3: Switch OFF the battery breaker, if the UPS will have the AC power disconnected for a long time.

3.3.4.2 Line Mode Turn Off Operation

The LCD diagrams are shown below when the UPS operates in the Line Mode.

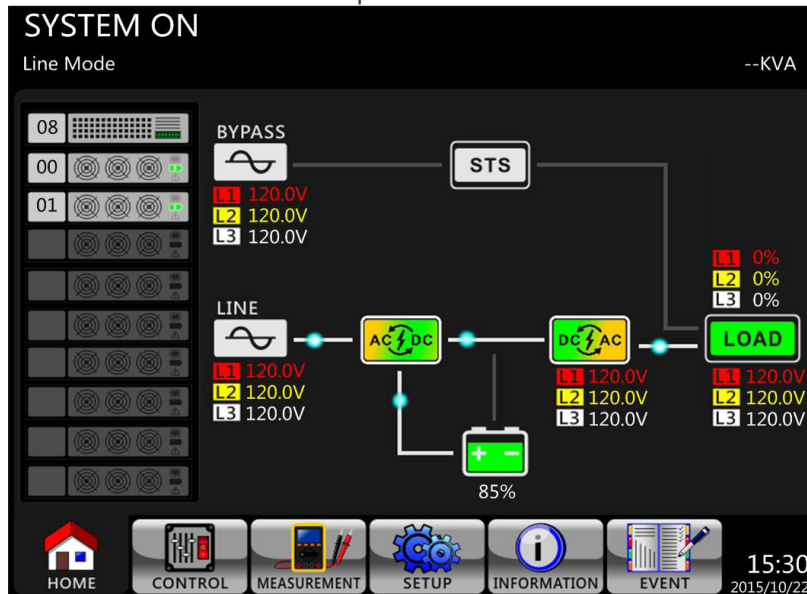

Press “Power On/Off” button for 2 seconds to turn off the UPS. Or use the Menu-Control-System Turn Off to turn off the UPS.

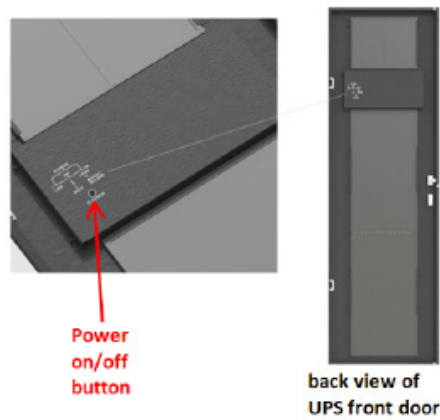

After turned off, the UPS will transfer to Standby Mode or Bypass Mode, depending on the "Bypass Mode" Setting. Next, follow the Bypass Mode/ Standby Mode Turn Off Operation procedure.

3.3.4.3 Battery Mode Turn Off Operation

The LCD diagram is shown below when the UPS operates in the Battery Mode.

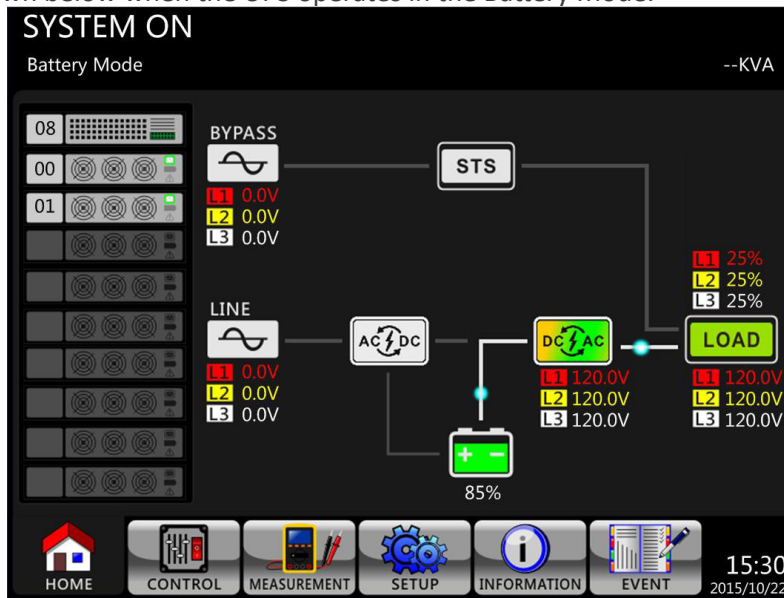

Press "Power On/Off" button for 2 seconds to turn off the UPS. Or use the Menu-Control-System Turn Off to turn off the UPS.

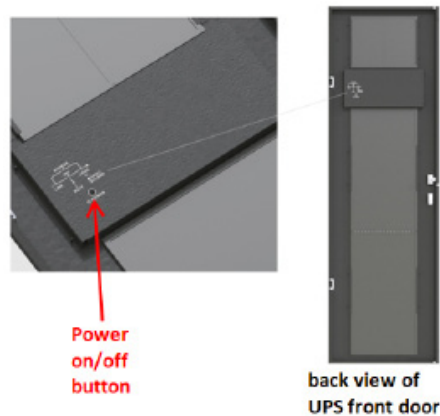

After turning off, the UPS will transfer to Standby Mode. Next, follow the **Bypass Mode/ Standby Mode Turn Off Operation** procedure.

4. Control Panel and Display Description

4.1 Introduction

The control panel and display are located on the front door of the UPS. The LCD is on the front. The LED indicators, the display description and the Power on/off button are on the back of the front door.

The control panel and display allows user control and monitoring of all measured parameters, UPS and battery status and alarms. The control panel and display are divided into four functional areas: (1) LCD display, (2) LED indications, (3) Control key, (4) Audio Alarm, as shown in Figure 4-1.

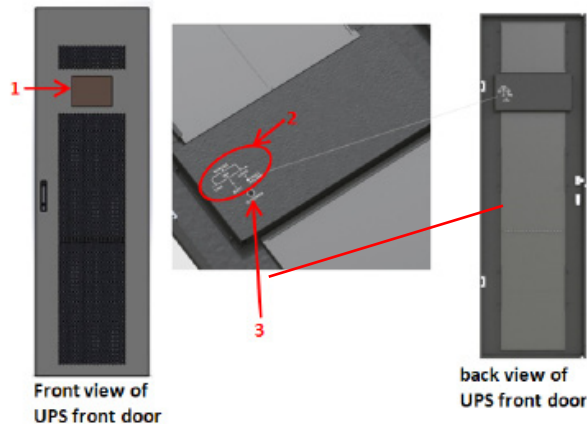

Figure 4-1 Control Panel

1. LCD display: Graphic display and all measured parameters.
2. LED indications. Refer to Table 4-1.
3. Control key. Refer to Table 4-2.
4. Audible Alarm. Refer to table 4-3.

Table 4.1: LED indications

LED	Color	Status	Definition
INPUT	Green	On	Input source is normal.
		Flashing	Input source is abnormal.
		Off	No input source
BYPASS	Yellow	On	Load on Bypass.
		Flashing	Input source is abnormal.
		Off	Bypass not operating.
LOAD	Green	On	There is power output for the load.
		Off	There is no power output for the load.
INVERTER	Green	On	Load on inverters.
		Off	Inverters not operating.
BATTERY	Red	On	Load on Battery.
		Flashing	Low battery
		Off	Battery converter is normal and battery is charging.
FAULT/ ALARM	Red	On	UPS fault.
		Flashing	UPS alarm.
		Off	Normal.

Table 4-2: Control key table

Control Key	Description
Power On/Off	Turn on UPS or Turn off UPS. (hold 2-Sec)

Table 4-3: Audible Alarm

Audio Type	Description
Power on/off	Buzzer sounds for two seconds.
Battery mode	Buzzer sounds every 2 seconds.
Low battery	Buzzer sounds every half second.
UPS alarm	Buzzer sounds every 1 second.
UPS fault	Buzzer sounds continuously.

4.2 Screen Description

4.2.1 Start Screen

Upon starting, the UPS executes self-test. The initial screen displays and remains still for approximately 5 seconds as shown in Figure 4-2.



Figure 4-2 Initial screen

4.2.2 Main Screen

After initialization, the main screen will display as Figure 4-3. Main screen is divided into six parts.

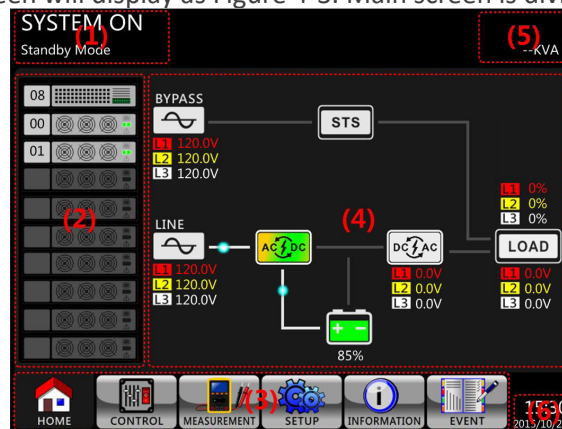











Figure 4-3 Main screen

(1) UPS Mode: Current Operation Mode.

(2) Module Status: It will show active module no. Touch each module icon to enter measurement screen. The meanings of each icon are listed as below.

Module icon	Explanation
	STS icon with ID no.
	Power module icon with ID no.
	No power module
	Power module output on
	Power module output off
	Power module charger on
	Power module charger off
	Power module fault
	Power module is operating normally.

(3) Main Menu: Touch icon to enter sub screen.

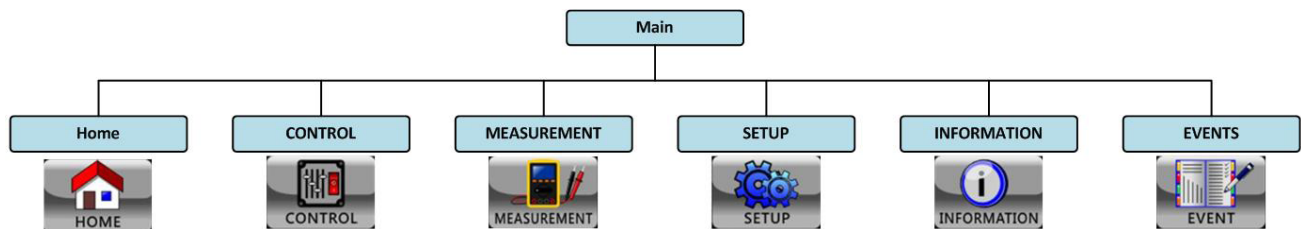

(4) UPS Flow Chart: Current flow chart and measurement data.

(5) UPS power rating.

(6) Date and Time.

4.2.3 Control Screen

Touch  icon to enter into the sub-menu as shown in Figure 4-5 and 4-6.

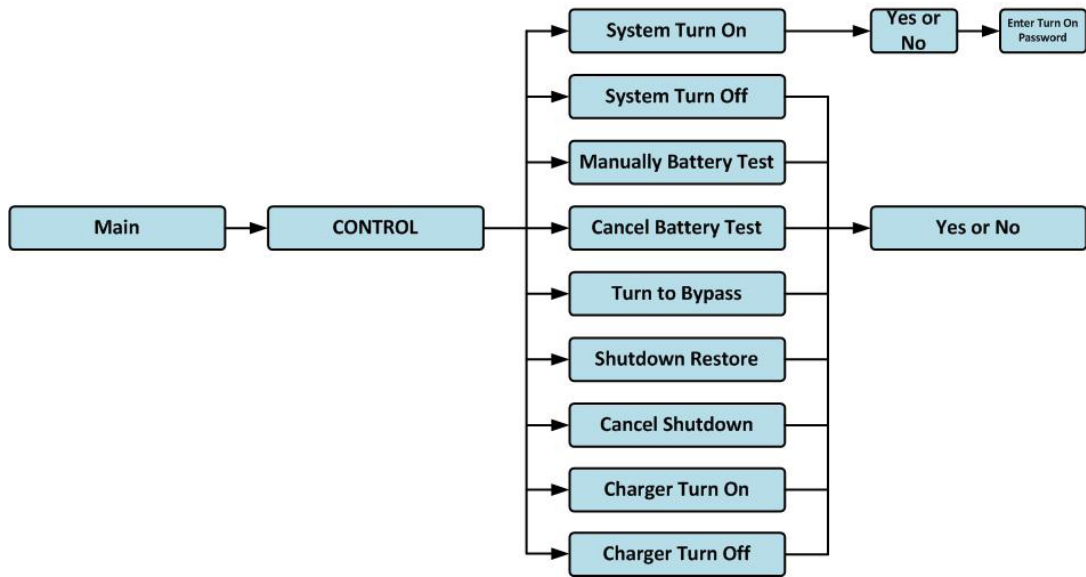

Figure 4-5 Control menu tree



Figure 4-6 Control screen page



Figure 4-7 Confirmation screen

Touch any control option directly. Then, confirmation screen will pop up. Touch **Yes** icon to confirm command or touch **No** icon to cancel command as shown in Figure 4-7.

4.2.5 Measurement Screen



Touch **MEASUREMENT** icon to enter into the sub-menu. There are two sub-menus, system measurement and module measurement. Touch **SYSTEM** icon to monitor system measurement value or **MODULE ID** icon to monitor module measurement value. You may choose Input, Output, Bypass, Load or Battery to monitor detailed status under “System” or “Module” directory. Please refer all screens in Figure 4-8 and 4-9. All detailed measurement items are listed in Table 4-4.

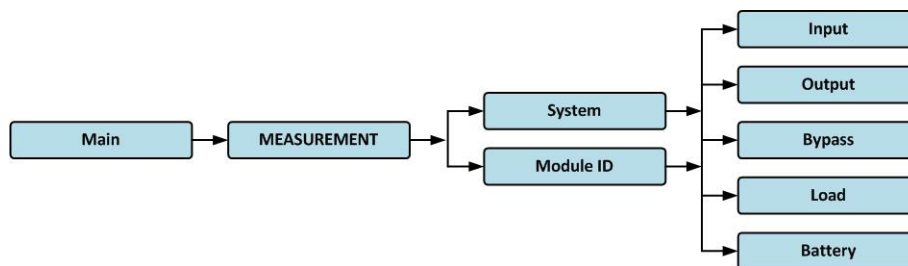

Figure 4-8 Measurement menu

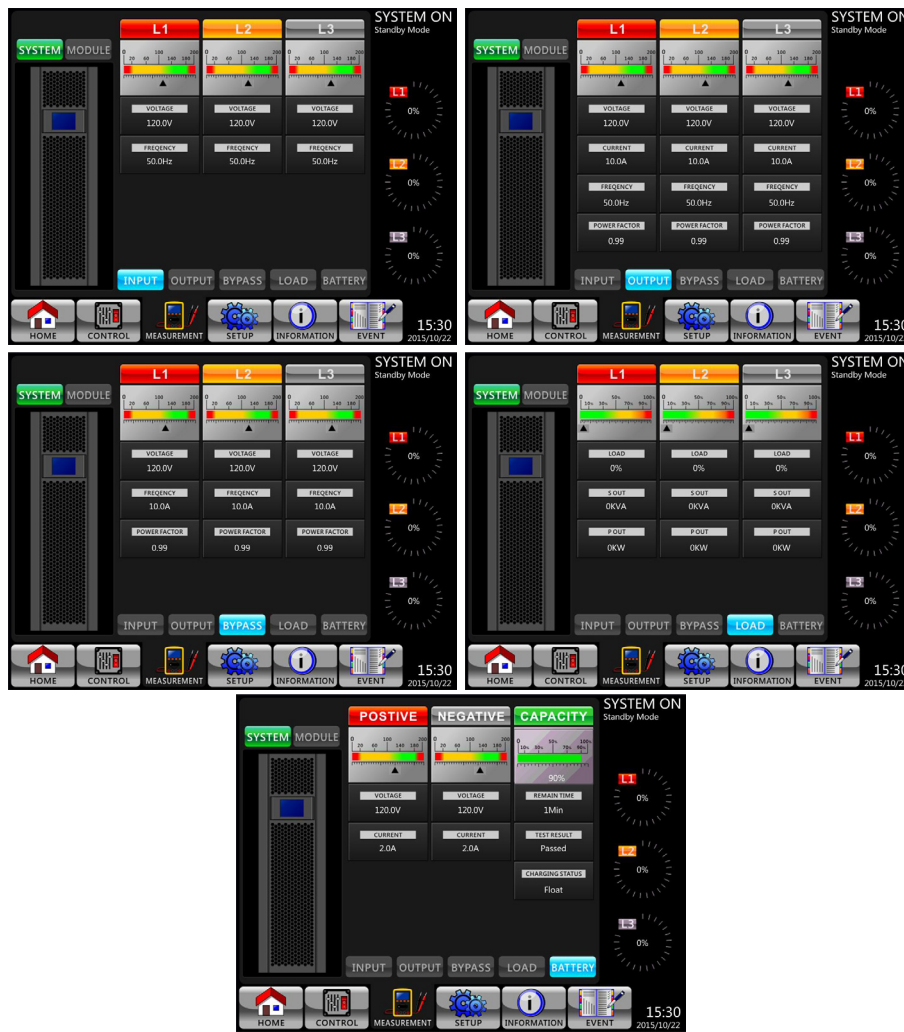

Figure 4-9 System Measurement Screens

Touch **MODULE** icon to monitor module measurement value.





Figure 4-10 Module Measurement Screens

The measurement can be read listed in Table 4-4.

Table 4-4: Measurement data

Menu	Item	Explanation
Input	L-N Voltage (V)	Input phase voltage (L1, L2, L3). Units 0.1V.
	Frequency (Hz)	Input Frequency (L1, L2, L3). Units 0.1Hz.
Output	L-N Voltage (V)	Output phase voltage (L1, L2, L3). Units 0.1V.
	L-N Current (A)	Output phase current (L1, L2, L3). Units 0.1A.
	Frequency (Hz)	Output Frequency (L1, L2, L3). Units 0.1Hz.
	Power Factor	Output Power Factor (L1, L2, L3).
Bypass	L-N Voltage (V)	Bypass phase voltage (L1, L2, L3). Units 0.1V.
	Frequency (Hz)	Bypass Frequency (L1, L2, L3). Units 0.1Hz.
	Power Factor	Bypass Power Factor (L1, L2, L3).
Load	Sout (KVA)	Apparent power. Units 0.1KVA.
	Pout (KW)	Active power. Units 0.1KW.
	Load Level (%)	The percentage of the UPS rating load. Units 1%.
Battery	Positive Voltage (V)	Battery Positive Voltage. Units 0.1V.
	Negative Voltage (V)	Battery Negative Voltage. Units 0.1V.
	Positive Current (A)	Battery Positive Current. Units 0.1A.
	Negative Current (A)	Battery Negative Current. Units 0.1A.
	Remain Time (min)	Battery runtime remaining. Units 1min.
	Capacity (%)	The percentage of the capacity of the battery. Units 1%.
	Test Result	Battery test result
	Charging Status	Battery charging status
	Temperature1(°)	Battery cabinet temperature of STS module. Units 0.1°.

4.2.6 Setup Screen

Touch the  icon to enter into the sub-menu. It's required to enter password to access General, SYSTEM, BATTERY and PRE-ALARM sub-menus as shown in Figure 4-11 and 4-12.

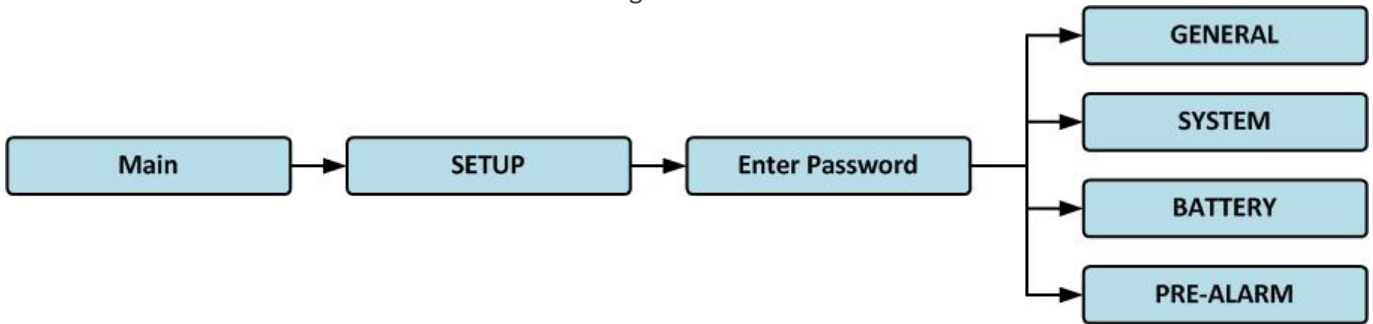

Figure 4-11 Setup menu

Touch the grey column and it will pop up number keyboard. Please enter 4-digit password and select  icon to enter SETUP sub-menu. If incorrect password is entered, the LCD screen will ask for retry.



Figure 4-12 Enter password screen

There are two levels of password protection, user password and maintainer password.

The default password for user is "0000". It can be changed by user.

The mantainer password is "0729".

Entering different levels of password can provide access to different settings. The setting can be changed in different operational mode. The Table 4-5 lists the relevant information.

Table 4-5: All setting items in Setup Menu

Setting item		Standby Mode	Bypass Mode	Line Mode	Battery Mode	Battery Test Mode	Fault Mode	Con-verter Mode	ECO Mode	Authorization		
										User	Main-tainer	
General	Model Name	Y	Y	Y	Y	Y	Y	Y	Y		Y	
	Language	Y	Y	Y	Y	Y	Y	Y	Y	Y	Y	
	TIME	Y	Y	Y	Y	Y	Y	Y	Y		Y	
	Change Password	Y	Y	Y	Y	Y	Y	Y	Y	Y	Y	
	Baud Rate	Y	Y	Y	Y	Y	Y	Y	Y	Y	Y	
	Audible Alarm	Y	Y	Y	Y	Y	Y	Y	Y	Y	Y	
	Factory Reset	Y										Y
	EEPROM Reset	Y										Y
	EPO Function	Y										Y
	Save Setting	Y	Y								Y	Y

System	Output Voltage	Y	Y							Y
	Bypass Voltage Range	Y	Y	Y	Y	Y	Y	Y	Y	Y
	Bypass Frequency Range	Y	Y							Y
	Converter Mode	Y								Y
	ECO Mode	Y	Y	Y					Y	Y
	Bypass Mode	Y	Y							Y
	Auto-Restart	Y	Y	Y	Y	Y	Y	Y	Y	Y
	Cold Start	Y	Y	Y	Y	Y	Y	Y	Y	Y
	Battery Mode Delay Time	Y	Y	Y			Y	Y	Y	Y
	System Shutdown Time	Y	Y	Y	Y	Y	Y	Y	Y	Y
	System Restore Time	Y	Y	Y	Y	Y	Y	Y	Y	Y
	Redundancy	Y	Y	Y	Y	Y	Y	Y	Y	Y
Battery	Charger Test	Y	Y	Y				Y	Y	Y
	Nominal Battery Voltage	Y	Y							Y
	Battery Capacity in Ah	Y	Y	Y			Y	Y	Y	Y
	Maximum Charging Current	Y	Y							Y
	Battery Low/Shutdown Setting	Y	Y	Y			Y	Y	Y	Y
	Periodic Battery Test	Y	Y	Y	Y	Y	Y	Y	Y	Y
	Battery Test Interval	Y	Y	Y	Y	Y	Y	Y	Y	Y
	Stop by Time	Y	Y	Y	Y		Y	Y	Y	Y
	Stop by Battery Voltage	Y	Y	Y	Y		Y	Y	Y	Y
	Stop by Battery Capacity	Y	Y	Y	Y		Y	Y	Y	Y
	Battery Age Alert	Y	Y	Y	Y	Y	Y	Y	Y	Y
	Temperature Compensation	Y	Y	Y	Y	Y	Y	Y	Y	Y
Pre-Alarm	Y	Y	Y	Y	Y	Y	Y	Y	Y	

"Y" means that this setting item can be set in this operational mode.

Setting Procedure

Step 1: Choose the setting item from GENERAL, SYSTEM, BATTERY and PRE-ALARM.

Step 2: Select item and it will show current value and setting in the screen. Choose current setting and it will list all alternatives. Please choose the modified setting.



Step 3: Choose  icon to confirm the setting change or choose  icon to cancel the setting.



Figure 4-13 Setting procedure

4.2.6.1 Setup-General Screen

The Setup-General screen and setting list are shown in Figure 4-14 and Table 4-6. General setting can be set in any operating mode.



Figure 4-14 Setup-General screen

Table 4-6: Setup-General setting list

Setting Item	Sub Item	Explanation
Model Name		Set UPS Name (xxxxxxxxxx). The max. length is 10 characters.
Language	--	Provides 3 optional LCD languages: <ul style="list-style-type: none"> • English (Default) • Traditional Chinese • Simplified Chinese
TIME	Adjust Time	Set current date and time. (yyyy / mm / dd hour : min : sec) MUST be set after UPS installation
	System Installed Date	Set system installed date (yyyy / mm / dd) 2015/1/1 (Default) MUST be set after UPS installation
	System Last Maintain Date	Set system latest maintenance date (yyyy / mm / dd) MUST be set after UPS installation
	Battery Installed Date	Set battery installed date(yyyy / mm / dd) MUST be set after UPS installation
	Battery Last Maintain Date	Set battery latest maintenance date(yyyy / mm / dd) MUST be set after UPS installation
Change Password	--	Set New Password. 0000 (Default)
Baud Rate	--	Set COM Port0 Baud Rate <ul style="list-style-type: none"> • 2400 (Default) • 4800 • 9600 Set COM Port1 Baud Rate <ul style="list-style-type: none"> • 2400 (Default) • 4800 • 9600

Audible Alarm	--	Set Audible Alarm <ul style="list-style-type: none"> • Disable • Enable (Default)
Factory Reset	--	Restore to factory default setting
EEPROM Reset	--	Set EEPROM default
EPO Function	--	Set EPO active status <ul style="list-style-type: none"> • Normal Close Active • Normal Open Active (Default)
Save Setting	--	Save EEPROM Use this feature to save the setting(s) you have done.

Table 4-7: EEPROM Reset Category list

Setting Item		Factory Reset	EEPROM Reset
General	Model Name		
	Language	Y	Y
	Adjust Time		
	System Installed Date		Y
	System Last Maintain Date		Y
	Battery Installed Date		Y
	Battery Last Maintain Date		Y
	Change Password		Y
	Baud Rate		Y
	Audible Alarm	Y	Y
	Factory Reset	--	--
	EEPROM Reset	--	--
	EPO Function		Y
	Save Setting	--	--
System	Output Voltage		Y
	Bypass Voltage Range	Y	Y
	Bypass Frequency Range	Y	Y
	Converter Mode	Y	Y
	ECO Mode	Y	Y
	Bypass Mode	Y	Y
	Auto-Restart	Y	Y
	Cold Start		Y
	Battery Mode Delay Time	Y	Y
	System Shutdown Time	Y	Y
	System Restore Time	Y	Y
	Redundancy		Y
Charger Test	--	--	

Battery	Nominal Battery Voltage	Y	Y
	Battery Capacity in Ah	Y	Y
	Maximum Charging Current	Y	Y
	Battery Low/Shutdown Setting	Y	Y
	Periodic Battery Test	Y	Y
	Battery Test Interval	Y	Y
	Stop by Time	Y	Y
	Stop by Battery Voltage	Y	Y
	Stop by Battery Capacity	Y	Y
	Battery Age Alert	Y	Y
Temperature Compensation	Y	Y	
Pre-Alarm			Y

4.2.6.2 Setup-System Screen

The Setup-System screen and setting list as shown in Figure 4-15 and table 4-8. System setting can be set only when UPS is operating in certain modes. Please check setting item availability table 4-5 for the details. If it's not set up under specific mode, the warning screen will appear. Refer to figure 4-16.



Figure 4-15 Setup-System screen

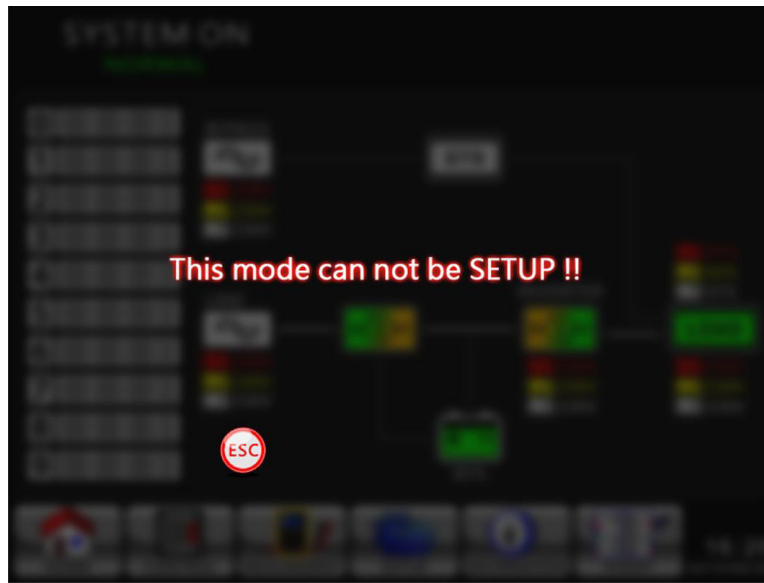

Figure 4-16 Warning screen

Table 4-8: Setup-System setting list

Setting Item	Sub Item	Explanation
Output Voltage	--	Set output voltage <ul style="list-style-type: none"> • 120Vac (Default) • 127Vac MUST be reviewed after UPS installation
BYPASS SETTING	Voltage	Set bypass voltage range: Upper limit <ul style="list-style-type: none"> • +10% • +15% (Default) • +20% Lower limit <ul style="list-style-type: none"> • -10% • -20% (Default) • -30%
	Frequency	Set bypass Frequency range: Upper/ Lower limit <ul style="list-style-type: none"> • +/- 1Hz • +/- 2Hz • +/- 4Hz (Default)
Converter Mode	--	Set converter mode <ul style="list-style-type: none"> • Disable (Default) • Enable
ECO Mode	--	Set ECO mode <ul style="list-style-type: none"> • Disable (Default) • Enable
Bypass Mode	--	Set bypass mode <ul style="list-style-type: none"> • Disable (Default) • Enable MUST be reviewed after UPS installation. If you need the Bypass power when UPS is OFF, please enable it.

Auto-Restart	--	<p>Set auto-restart</p> <ul style="list-style-type: none"> • Disable • Enable (Default) <p>After "Enable" is set, once UPS shutdown occurs due to low battery and then utility restores, the UPS will return to line mode.</p>
Cold Start	--	<p>Set cold start</p> <ul style="list-style-type: none"> • Disable • Enable (Default) <p>After "Enable" is set, the UPS can be turned on without connecting to utility by pressing Battery Start Button. Refer to cold start operation for the details.</p>
Battery Mode Delay Time	--	<p>Set system shutdown delay time in battery mode (0~9990sec).</p> <ul style="list-style-type: none"> • 0: Disable (Default) • Not 0: Enable <p>When this feature is enabled, UPS will shut off output after UPS operates in Battery mode for certain seconds.</p>
System Shutdown Time	--	<p>Set system shutdown time (0.2~99min)</p> <ul style="list-style-type: none"> • 0.2 min (Default) <p>This delay time will start counting when the CONTROL-Shutdown Restore command is executed.</p>
System Restore Time	--	<p>Set system restore time (0~9999min)</p> <ul style="list-style-type: none"> • 1 min (Default) <p>This delay time will start counting after shutdown time is elapsed when the CONTROL-Shutdown Restore command is executed.</p>
Redundancy	--	<p>Set total power and redundancy</p> <p>Total Power: the QTY of Power Modules</p> <p>Redundancy: the QTY of redundant power module</p> <p>MUST be set after UPS installation or the QTY of Power Module is changed</p>
Charger Test	--	<p>Set charger test</p> <ul style="list-style-type: none"> • Disable (Default) • Enable

4.2.6.3 Setup-Battery Screen

The Setup-Battery screen and setting list as shown in Figure 4-17 and table 4-9. Battery setting can be set only when UPS is operated in standby mode. If it's not in standby mode, the warning screen will appear as shown in Figure 4-16.

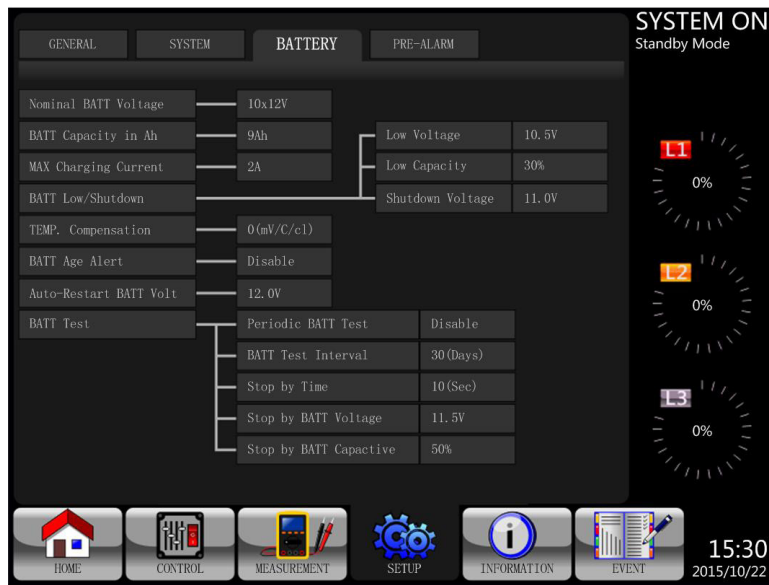

Figure 4-17 Setup-Battery Screen

Table 4-9: Setup-Battery setting list

Setting Item	Sub Item	Explanation
Nominal Battery Voltage	--	Set battery nominal voltage • 10x12V (Default) MUST be set after UPS installation
Battery Capacity in Ah	--	Set battery capacity. (0~999) • 9Ah (Default) MUST be set after UPS installation or Battery capacity is changed.
Maximum Charging Current	--	Set battery maximum charging current (1~128A) • 2A (Default) MUST be set after UPS installation or Battery capacity is changed.
Battery Low/Shutdown SETTING	Battery Low Voltage	Set battery low voltage (10.5~11.5V)x(battery Number) • 11V x Battery Number (Default)
	Battery Low Capacity	Set battery low capacity (20~50%) • 20% (Default)
	Battery Shutdown Voltage	Set battery voltage point for system shutdown in battery mode (10.0~11V) x (battery Number) • 10V x Battery Number (Default)

BATTERY TEST	Periodic Battery Test	Set periodic battery test disable or enable <ul style="list-style-type: none"> • Disable (Default) • Enable
	Battery Test Interval	Set battery test interval (7~99 Days) <ul style="list-style-type: none"> • 30 Days (Default)
	Stop by Time	Set testing time for battery test (10~1000sec) <ul style="list-style-type: none"> • 10 sec (Default)
	Stop by Battery Voltage	Set stop battery voltage in battery test (11~12V) x (battery Number) <ul style="list-style-type: none"> • 11V x Battery Number (Default)
	Stop by Battery Capacity	Set battery capacity to stop battery-testing. (20~50%) <ul style="list-style-type: none"> • 20% (Default)
Battery Age Alert	Battery Age Alert (Months)	Set battery age for replacement. (Disable,12~60Months) <ul style="list-style-type: none"> • Disable (Default) If this feature is enabled and the battery has been installed over this period, there is a warning "Battery Age Alert" to indicate it.
Temperature Compensation	--	Set battery temperature compensation. (0~-5 (mV/°C/cl)) <ul style="list-style-type: none"> • 0(mV/°C/cl) (Default)
Auto-Restart Battery Voltage	--	<ul style="list-style-type: none"> • Set auto-restart battery voltage. (0 or 12.0V ~ 13.0V) • 0V (default) • If set to 0V, the UPS will immediately auto-restart upon AC return. Otherwise, the UPS will first charge the battery to the set value and then auto-restart.

4.2.6.4 Pre-Alarm Screen

The Setup-Pre-Alarm screen and setting list as shown in Figure 4-18 and table 4-10. Pre-Alarm setting can be set in any operation mode.



Figure 4-18 Setup-Pre-Alarm screen

Table 4-10: Setup-Pre-Alarm setting list

Setting Item	Sub Item	Explanation
Line Voltage Range	--	Set line voltage range: Upper limit <ul style="list-style-type: none"> +5% +10% +15% +20% (Default) Lower limit <ul style="list-style-type: none"> -5% -10% -15% -20% (Default)
Line Frequency Range	--	Set line frequency range: Upper / Lower limit <ul style="list-style-type: none"> +/- 1Hz +/- 2Hz +/- 3Hz +/- 4Hz (Default)
Load	--	Set UPS Overload percentage (40~100%) <ul style="list-style-type: none"> 100% (Default) Set UPS load unbalance percentage (20~100%) <ul style="list-style-type: none"> 100% (Default)

4.2.7 Information Screen



Touch  icon to enter into the sub-menu. In this Information screen, you can check the UPS configuration of the unit. There are three sub-menus, Identification, System and Battery.

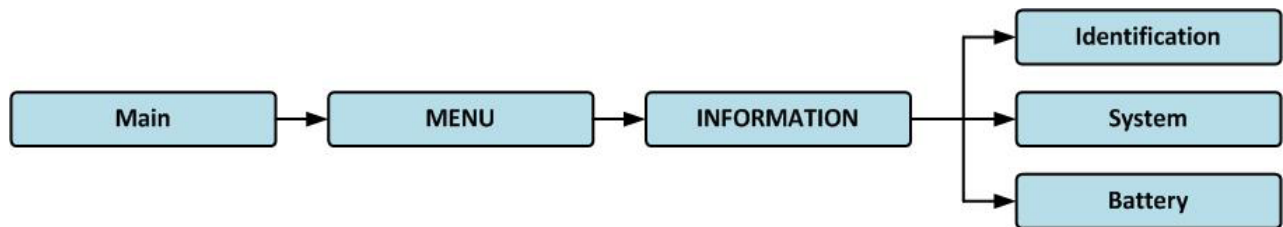

Figure 4-19 Information menu

4.2.7.1 INFORMATION - Identification Screen

When Identification submenu is clicked, the Model Name, Serial No. and Firmware Version will be displayed, as shown in Figure 4-20.

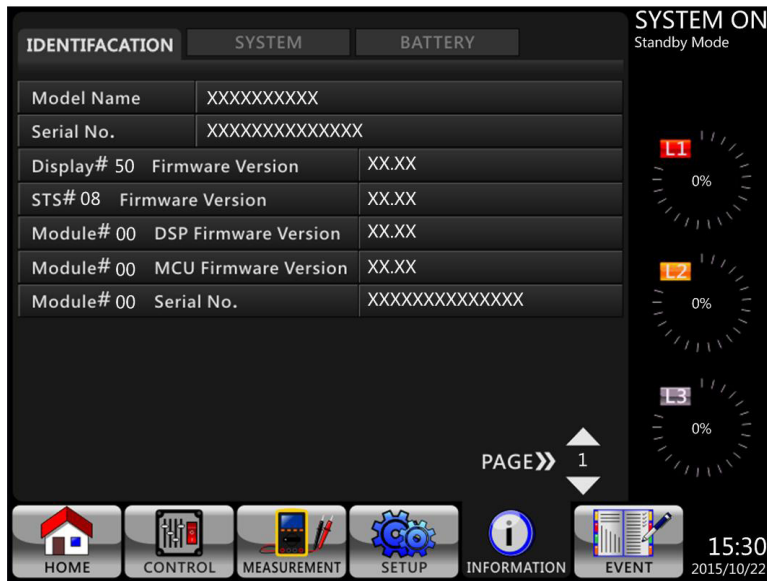

Figure 4-20 Identification screen page

4.2.7.2 INFORMATION - System Screen

When System submenu tab is touched, the system power, nominal voltage, nominal frequency ... etc. information will be displayed, as shown in Figure 4-21 and 4-22. Touch UP and DOWN arrows to switch different pages.

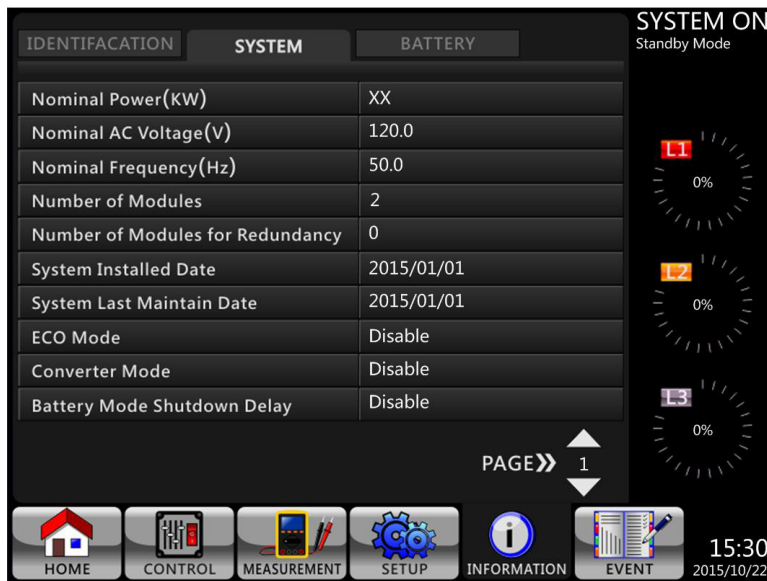

Figure 4-21 INFORMATION System screen page 1



Figure 4-22 INFORMATION System screen page 2

4.2.7.2 INFORMATION - Battery Screen

When Battery submenu tab is touched, the Battery nominal voltage, capacity, charging current ... etc. information will be displayed, as shown in Figure 4-23

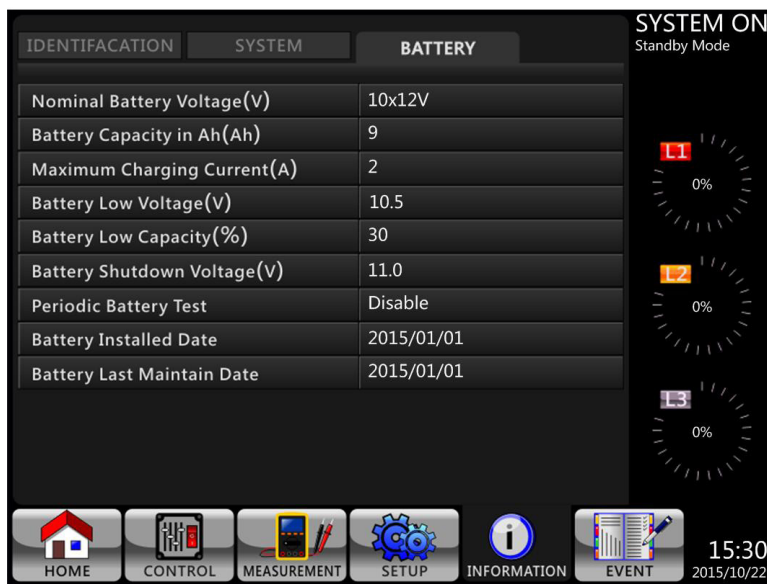



Figure 4-23 INFORMATION Battery screen page

4.2.8 Events Screen

When event occurs, you will see flashing  icon in the Main Screen as shown in Figure 4-24. You also can touch  icon to check the latest event lists, history events and reset all events as shown in Figure 4-25.

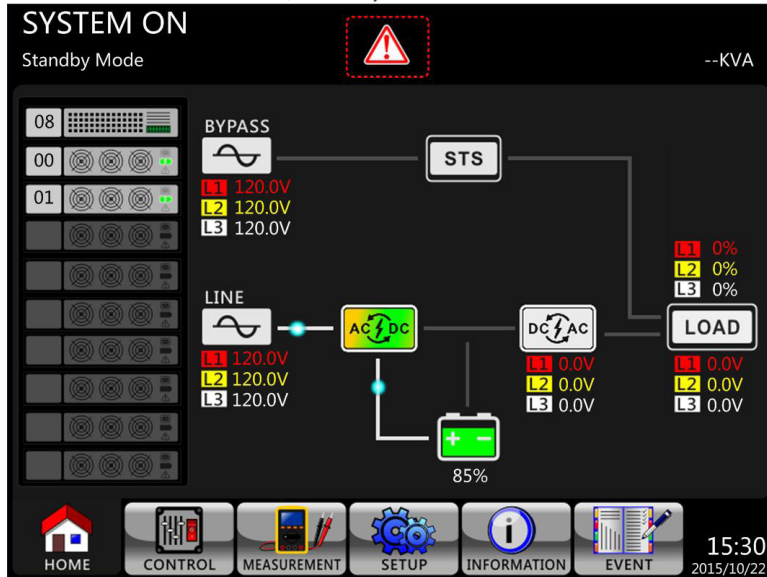

Figure 4-24 Alarm warning screen



Figure 4-25 Events menu

4.2.8.1 Current Events

When event occurs, it will display Module ID and alarm code in Current Events screen. It can save up to 50 events in current list. Only 10 events can be listed in one page.

If there are more than 10 current events, press  icon to read other event as shown in Figure 4-26.



Figure 4-26 Current Events screen

4.2.8.2 History Events

The detailed event information is saved in history events. It can save up to 500 events in history events. When warning occurs, it will display alarm code, alarm time and Module ID. When fault event occurs, it will display alarm details, alarm time and Module ID. (Refer to Table 4-12 Alarm List) In order to record more historical information about the UPS system, the important setting changed (refer to Table 4-13 Important setting changed), UPS operation mode changes (refer to Table 4-14 UPS mode change) and control action executes (refer to Table 4-15 Control execution) will be saved in History Events. Refer to Figure 4-27 for display screen.



Figure 4-27 History Events screen

4.2.8.3 Reset All Events

The Maintainer password is required to enter Reset All Events screen as shown in Figure 4-28. After entering correct password, it will pop up reconfirmed screen. Then, touch **Yes** icon to reset all events or touch **No** icon to cancel this action as shown in Figure 4-29.

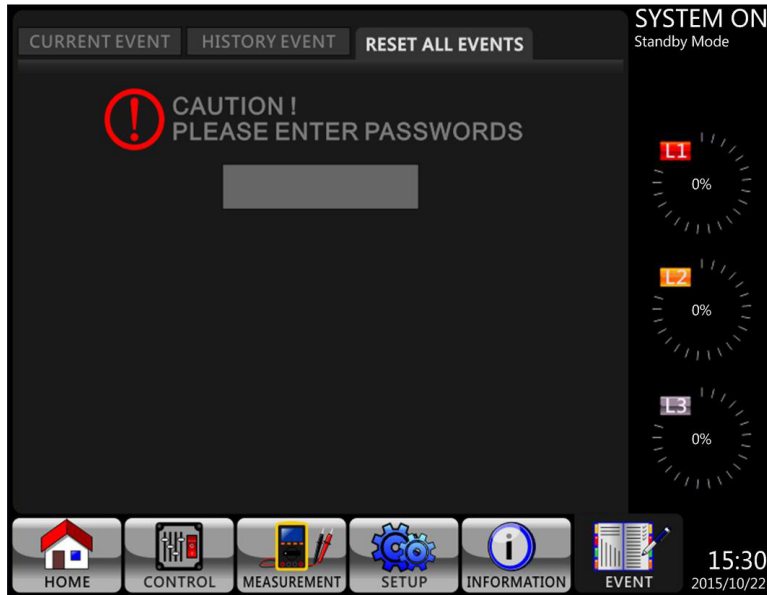

Figure 4-28 Reset All Events screen

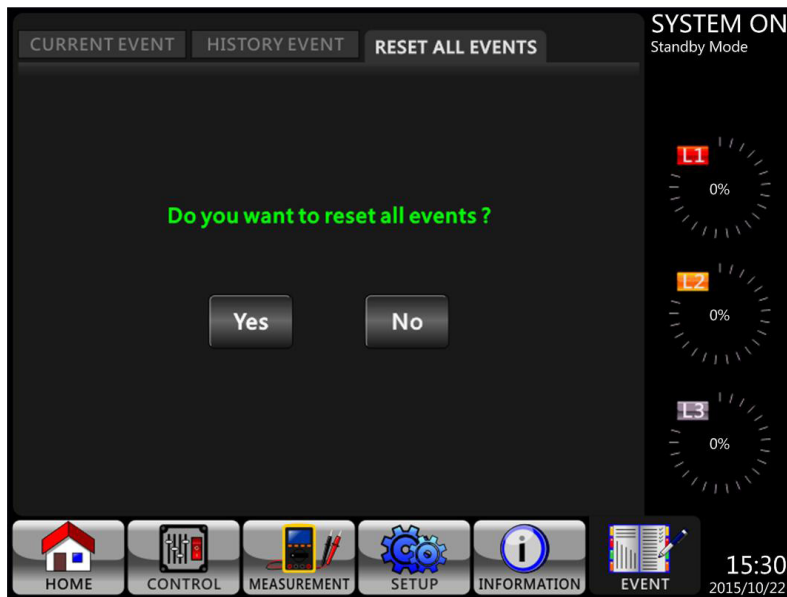

Figure 4-29 Reset All Events Confirmation screen

4.3 Alarm List

Table 4-12 provides the complete list of UPS alarm messages.

Table 4-12: Alarm List

Representation in display LCD	Explanation
Fault! Bus Over Voltage	DC bus voltage is too high
Fault! Bus Under Voltage	DC bus voltage is too low

Fault! Bus Voltage Unbalance	DC bus voltage is not balanced
Fault! Bus Short	DC bus is short
Fault! Bus Soft Start Time Out	The rectifiers can't start due to low DC bus voltage within specified duration
Fault! Inverter Soft Start Time Out	Inverter bus voltage cannot reach desired voltage within specified duration
Fault! Inverter Voltage Over	Inverter Voltage is over Peak Value.
Fault! Inverter Voltage High	Inverter Voltage is too high
Fault! Inverter Voltage Low	Inverter Voltage is too Low
Fault! R Inverter Voltage Short	R phase inverter Output is short-circuited.
Fault! S Inverter Voltage Short	S phase inverter Output is short-circuited.
Fault! T Inverter Voltage Short	T phase inverter Output is short-circuited.
Fault! RS Inverter Voltage Short	R-S inverter Output is short-circuited.
Fault! ST Inverter Voltage Short	S-T inverter Output is short-circuited.
Fault! TR Inverter Voltage Short	T-R inverter Output is short-circuited.
Fault! Inverter R Negative Power	R phase inverter Output Negative Power over range
Fault! Inverter S Negative Power	S phase inverter Output Negative Power over range
Fault! Inverter T Negative Power	T phase inverter Output Negative Power over range
Fault! Over Load Fault	Heavy overload causes UPS fault.
Fault! Battery Fault	Batteries reversed
Fault! Over Temperature	Make sure adequate space is allowed for air ventilation and the fan is working
Fault! CAN Fault	CAN communication fault
Fault! TRIGO Fault	Synchronized trigger signal fault
Fault! Relay Fault	Inverter relay fault
Fault! Line SCR Fail	Line SCR short circuit fault
Fault! EEPROM Fault	EEPROM operation error
Fault! Parallel Cable Loosen Fault	As stated.
Fault! DSP MCU Stop Communicate	As stated.
Fault! Bypass Temperature Fault	As stated
Fault! Bypass SCR Fault	As stated.
Line Fail	Utility lost or abnormal
Line Restore	Utility recovered to normal
Warning! EPO Active	Check the EPO connector
Warning! Over Load Fail	The load devices are demanding more power than the UPS can supply. Line mode will transfer to Bypass mode.
Warning! Communicate CAN Fail	CAN communication error
Warning! Over Load	In Line mode, the load devices are demanding more power than the UPS can supply.
Warning! Battery Open	Battery not connected
Warning! Battery voltage High	Battery voltage is too High
Warning! Module Un-Lock	As stated.

Warning! Turn On Abnormal	As stated.
Warning! Charge Fail	As stated.
Warning! EEPROM Fail	EEPROM operation error
Warning! Fan Lock	As stated.
Warning! Line Phase Error	As stated.
Warning! Bypass Phase Error	As stated.
Warning! N Loss	Neutral loss
Warning! Internal Initial Fail	As stated.
Warning! Comm Syn Signal Fail	Communicate Synchronization Signal Fail
Warning! Comm. TRIG0 Fail	Communicate Trigger signal fault
Warning! Redundancy Set Fail	As stated.
Warning! Parallel Sys Config. Wrong	Parallel System Configure error
Warning! Maintenance Bypass	Enter maintenance
Warning! Battery Age Alert	Battery Life expiration
Warning! Parallel Rack Cable Loosen	As stated.
Warning! Parallel Rack Config. Wrong	Parallel Rack Configure error
Warning! Parallel Firmware Error	Power module parallel firmware error
Warning! Battery Voltage Low	Battery voltage is too low.
Warning! ID Conflict	Power module ID conflict.
Pre-Alarm! Line Voltage Fail	Line voltage over range
Pre-Alarm! Line Voltage Normal	Line voltage recovered to normal
Pre-Alarm! Line Frequency Unstable	Line frequency over range
Pre-Alarm! Line Frequency Normal	Line frequency recovered to normal
Pre-Alarm! Over Load	Output Load over range
Pre-Alarm! Load Normal	Output Load recovered to normal
Pre-Alarm! Load Unbalance	Output Load unbalance

4.4 History Record

In addition to faults, alarms and history events, the history record also includes UPS mode changes, and control functions as itemized in 4-13, 4-14, 4-15.

Table 4-13: Important setting changed

Item No.	Description	Item No.	Description
1	Setup! Model Name	2	Setup! Turn On Password
3	Setup! Language	4	Setup! Change Turn On Password
5	Setup! Adjust Time	6	Setup! Nominal Power Display
7	Setup! System Installed Date	8	Setup! Output Voltage
9	Setup! System Last Maintain Date	10	Setup! Bypass Voltage Range
11	Setup! Battery Installed Date	12	Setup! Bypass Frequency Range
13	Setup! Battery Last Maintain Date	14	Setup! Converter Mode
15	Setup! Change Password	16	Setup! ECO Mode
17	Setup! Baud Rate	18	Setup! Bypass Mode
19	Setup! Audible Alarm	20	Setup! Auto-Restart

21	Setup! Factory Reset	22	Setup! Cold Start
23	Setup! EEPROM Reset	24	Setup! Battery Mode Delay Time
25	Setup! EPO Function	26	Setup! Shutdown Restore Time
27	Setup! Save Setting	28	Setup! Redundancy
29	Setup! Power Rating Setting	30	Setup! Charger Test
31	Setup! Nominal Battery Voltage	32	Setup! Battery Capacity in Ah
33	Setup! Maximum Charging Current	34	Setup! Battery Low Voltage
35	Setup! Battery Low Capacity	36	Setup! Battery Shutdown Voltage
37	Setup! Periodic Battery Test	38	Setup! Stop By Time
39	Setup! BATTERY Age Alert	40	Setup! Temperature Compensation
41	Setup! Charging Voltage	42	Setup! PRE-ALARM
43	Setup! UPS Parallel	44	Setup! Independent Battery

Table 4-14: UPS mode change

Item No.	Description	Item No.	Description
1	UPS Mode! Power On Mode	2	UPS Mode! Standby Mode
3	UPS Mode! Bypass Mode	4	UPS Mode! Line Mode
5	UPS Mode! Battery Mode	6	UPS Mode! Battery Test Mode
7	UPS Mode! Fault Mode	8	UPS Mode! Converter Mode
9	UPS Mode! ECO Mode	10	UPS Mode! Shutdown Mode
11	UPS Mode! Un-Connection	12	

Table 4-15: Control execution

Item No.	Description	Item No.	Description
1	Control! System Turn On	2	Control! System Turn Off
3	Control! Manual Battery Test	4	Control! Cancel Battery Test
5	Control! Turn To Bypass	6	Control! Shutdown Restore
7	Control! Cancel Shutdown	8	Control! Charger Turn On
9	Control! Charger Turn Off	10	

5. Interface and Communication

As shown in figure 5-1, the Static Transfer Switch (STS) Module includes dry contact Ports (CN1~CN8), Extra Comm. Slot, SNMP Slot and communication port (RS232 Port, USB port) on the front panel.

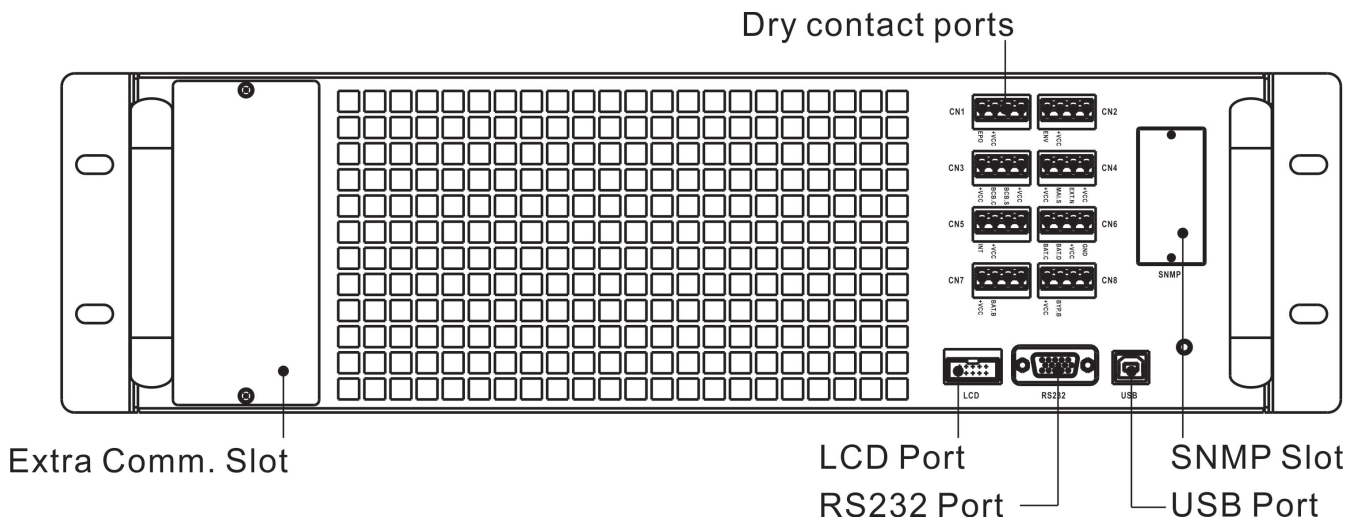

Figure 5-1 Dry contact ports and communication ports

Dry Contact No.	Dry Contact No.	Function
	CN1	Remote EPO input port
	CN2	Future use
	CN3	Future use
	CN4	Maintenance Bypass Switch State Port
	CN5	Future use
	CN6	Battery Cabinet Temperature Detection Port
	CN7	Future use
	CN8	Future use

5.1 Dry Contact Port

5.1.1 CM1-Remote EPO Input Port

The Emergency Power off (EPO) Function in UPS can be operated by an assigned remote contact. Users can set the logic (N.C or N.O) of this EPO Function through LCD panel.

CN1 is the remote EPO input port. The port is shown in Figure 5-2 and described in Table 5-1.

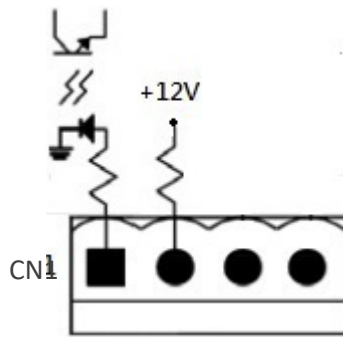

Figure 5-2 Remote EPO input port

Table 5-1: Description of remote EPO port

EPO Logic Setting	Position	Description
N.C	X1.1 & X1.2	EPO is activated when X1.1 & X1.2 opened
N.O	X1.1 & X1.2	EPO is activated when X1.1 & X1.2 shortened

If EPO Logic setting is Normal Closed (N.C), EPO is triggered when pins 1 and 2 of X1 are opened. Otherwise, EPO Logic setting is Normal Opened (N.O). EPO is triggered when pins 1 and 2 of X1 are closed.

Note:

1. EPO function activates shutdown of the rectifiers, inverters and static transfer switch. But it does not internally disconnect the input power supply.
2. The default setting of the EPO function logic is Normal Opened (N.O).

5.1.2 X4-Maintenance Bypass Switch State Port

X4 is the maintenance bypass switch port. The port is shown in Figure 5-3 and described in Table 5-2.

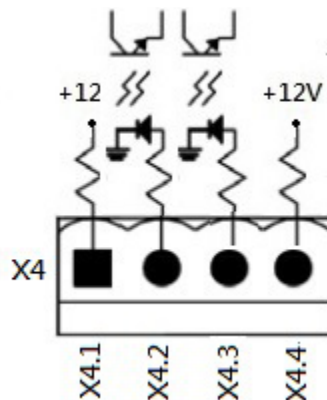

Figure 5-3 Maintenance Bypass Switch State port

Table 5-2: Description of Maintenance Bypass Switch State port

Name	Position	Description
Maintain Bypass Pin1	X4.1	Maintenance bypass switch state
Maintain Bypass Pin 2	X4.2	Maintenance bypass switch state
	X4.3	Future use
	X4.4	Future use

5.1.3 X6-Battery Cabinet Temperature Detection Port

There is battery cabinet temperature detection function in the UPS. The temperature of UPS battery cabinet can be detected through the external battery cabinet temperature detection sensor. Communication between the UPS and Battery temperature detection board was through I2C communication protocol. X6 is the battery cabinet temperature detection port. This option requires an optional temperature probe. The port is shown in Figure 5-4 and described in Table 5-3.

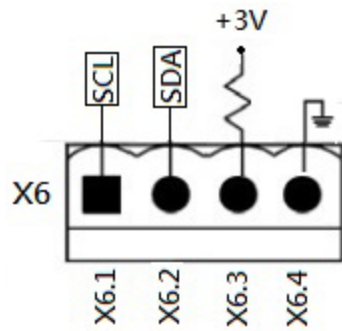

Figure 5-4 Battery Cabinet Temperature Detection Port

Table 5-3: Description of Battery Cabinet Temperature Detection Port

Name	Position	Description
SCL	X6.1	I ² C communication SCL Signal
SDA	X6.2	I ² C communication SDA Signal
+3.0V	X6.3	3V
Power GND	X6.4	GND

5.2 Extra Comm. Slot

There is an optional card, Extra Comm. Card which can be inserted into this slot. This option can enhance the communication capability of the modular UPS. It provides programmable dry contact signals, temperature sensors ports and an additional SNMP Slot.

5.3 Local Communication Ports – RS232 & USB

Note: The RS232 and USB ports can't be used simultaneously.

5.4 SNMP Slot

The SNMP card, modbus card, or relay card can be inserted into this slot to work with the UPS.

6. Troubleshooting

The M90U-80 & 140 can alarm for the following faults or warnings:

LCD Message	Explanation	Solution
Fault! Bus Over Voltage	DC bus voltage is too high	Contact service personnel.
Fault! Bus Under Voltage	DC bus voltage is too low	Contact service personnel.
Fault! Bus Voltage Unbalance	DC bus voltage is not balanced	Contact service personnel.
Fault! Bus Short	DC bus is short	Contact service personnel.
Fault! Bus Soft Start Time Out	The rectifiers could not start due to low DC bus voltage within specified duration	Turn off UPS and then restart the UPS. If it fails again, contact service personnel.
Fault! Inverter Soft Start Time Out	Inverter voltage cannot reach desired voltage within specified duration	Turn off UPS and then restart the UPS. If it fails again, contact service personnel.
Fault! Inverter Voltage Over	Inverter Voltage over (Peak Value)	Contact service personnel.
Fault! Inverter Voltage High	Inverter Voltage is too high	Contact service personnel.
Fault! Inverter Voltage Low	Inverter Voltage is too Low	Contact service personnel.
Fault! R Inverter Voltage Short	R phase inverter Output is shorted	Contact service personnel.
Fault! S Inverter Voltage Short	S phase inverter Output is shorted	Contact service personnel.
Fault! T Inverter Voltage Short	T phase inverter Output is shorted	Contact service personnel.
Fault! RS Inverter Voltage Short	R-S inverter Output is shorted	Contact service personnel.
Fault! ST Inverter Voltage Short	S-T inverter Output is shorted	Contact service personnel.
Fault! TR Inverter Voltage Short	T-R inverter Output is shorted	Contact service personnel.
Fault! Inverter R Negative Power	R phase inverter Output Negative Power over range	Contact service personnel.
Fault! Inverter S Negative Power	S phase inverter Output Negative Power over range	Contact service personnel.
Fault! Inverter T Negative Power	T phase inverter Output Negative Power over range	Contact service personnel.
Fault! Over Load Fault	Heavy overload causes UPS fault.	Reduce some load.
Fault! Battery Fault	Battery reverse	Check the polarity of battery connection and contact service personnel.
Fault! Over Temperature	Make sure adequate space is allowed for air vents and the fan is working	Check if the ambient temperature is over specification. Or contact service personnel.
Fault! CAN Fault	CAN communication fault	Contact service personnel.
Fault! TRIGO Fault	Synchronized trigger signal fault	Contact service personnel.

Fault! Line SCR Fail	Line SCR short circuit fault	Contact service personnel.
Fault! EEPROM Fault	EEPROM operation error	Contact service personnel.
Fault! Parallel Cable Loosen Fault	As stated.	Check if the parallel cable is loose and contact service personnel.
Fault! DSP MCU Stop Communicate	As stated.	Contact service personnel.
Fault! Bypass Temperature Fault	As stated	Check if the ambient temperature is over specification. Or contact service personnel.
Fault! Bypass SCR Fault	As stated.	Contact service personnel.
Warning! EPO Active	Check the EPO connector	Check if the connector is loose when EPO acts abnormally.
Warning! Over Load Fail	The load devices are demanding more power than the UPS can supply. Line mode will transfer to Bypass mode.	Reduce some load and check output Load-Capacity and specification
Warning! Communicate CAN Fail	CAN communication error	Contact service personnel.
Warning! Over Load	In Line mode, the load devices are demanding more power than the UPS can supply.	Reduce some load and check output Load-Capacity and specification
Warning! Battery Open	Battery not connected	<ol style="list-style-type: none"> 1. Check battery breaker. 2. Check if the battery connection is well connected. 3. Check the setting of Nominal Battery voltage. 4. Contact service personnel if necessary
Warning! Battery voltage High	Battery voltage is too High	Check the setting of Nominal Battery voltage and contact service personnel.
Warning! Module Un-Lock	As stated.	Check if module is locked well.
Warning! Turn On Abnormal	As stated.	Check if the input voltage or frequency is out of range.
Warning! Charge Fail	As stated.	Contact service personnel.
Warning! EEPROM Fail	EEPROM operation error	Contact service personnel.
Warning! Fan Lock	As stated.	Check if the fan is blocked or contact service personnel.
Warning! Line Phase Error	As stated.	Check if the Mains phase sequence is correct and contact service personnel.
Warning! Bypass Phase Error	As stated.	Check if the Bypass phase sequence is correct and contact service personnel.
Warning! N Loss	Neutral loss	Check if the Neutral connection is well and contact service personnel..
Warning! Internal Initial Fail	As stated.	Contact service personnel.
Warning! Comm. Syn. Signal Fail	Communicate Synchronization Signal Fail	Contact service personnel.
Warning! Comm. TRIGO Fail	Communicate Trigger signal fault	Contact service personnel.

Warning! Redundancy Set Fail	As stated.	Check the redundancy setting is correct and contact service personnel.
Warning! Parallel Sys Config. Wrong	Parallel System Configure error	Contact service personnel.
Warning! Maintenance Bypass	Enter maintenance	Check if the connector is loose when it acts abnormally.
Warning! Battery Age Alert	Battery Life expiration	Check if the battery has been used over its service age. Or contact service personnel.
Warning! Parallel Rack Cable Loosen	As stated.	Check if the Parallel Rack Cable is loose and contact service personnel.
Warning! Parallel Rack Config. Wrong	Parallel Rack Configure error	Check the Parallel Rack Setting is correct and contact service personnel.
Warning! Parallel Firmware Error	Power module parallel firmware error	The firmware version does not support Rack Parallel feature. Contact service personnel.
Warning! ID Conflict	Power module ID conflict.	There are two Power Modules with the same ID numbers. Change the repeated ID to release it. Or contact service personnel.

7. Service



This chapter introduces the UPS service, including the service procedures of the power module, STS, control module, battery module and air filter.

Warning:

1. Only trained customer service engineers can service the power modules, bypass module and battery modules.
2. Remove the power modules, bypass module and battery modules from top to bottom to prevent cabinet from toppling due to high center of gravity.
3. The static transfer switch module is NOT hot pluggable. It should be replaced only when the UPS is in maintenance bypass mode or completely powered off.

7.1 Replacement Procedures of the Power Module

Warning:

- Confirm UPS is in Line mode or Bypass mode.
 - Confirm at least one Power Module remains in the UPS cabinet after one Power Module is removed
 - If all power modules have to be removed, the replacement MUST be completed under Maintenance Bypass Operation Mode.
1. Turn ready switch to “” position
 2. The Power Module FAULT LED (RED) indicator is lit to indicate the Power Module output is off and disconnected from UPS system.
 3. Use a screwdriver to remove the four screws, securing the power module.
 4. Pull out and remove the Power Module from its slot.
 5. After servicing the module, confirm that the DIP switch of the module is set correctly and the ready switch is in unready state “”.
 6. Push the module into the cabinet and tighten the screws on both sides. If there are more than one power modules to re-install, please wait 30-second before installing another module.
 7. The re-installed Power Module will be turned on automatically when UPS is in line mode.

7.2 Replacement Procedures of the STS Module

Warning:

Confirm the UPS is operating in Maintenance Bypass Mode.

1. Follow Section "3.3.3.1 Transfer to maintenance bypass" procedure to transfer UPS into Maintenance Bypass operation.
2. Remove the screws on both sides of the front panel of the module and pull the module out from the cabinet.
3. After servicing the module, push the module into the cabinet and tighten the screws on both sides.
4. Follow chapter "3.3.3.2 Transfer to UPS Protection" procedure to transfer UPS into Bypass operation
5. Press menu > control > system turn on > YES to turn UPS on.

7.3 Replacement Procedures of the Battery Module

Warning:

Confirm the types of battery are the same.

1. Remove the fixing screws on both sides of the front panel of the module, and pull out the battery module.
2. Push the new battery module into cabinet and secure it with screws on both sides of the front panel.

7.4 Replacement Procedures of the Air Filter

As shown below, the UPS provides two air filters on the rear of the front door. Each filter is secured by a fixing bar on both sides.

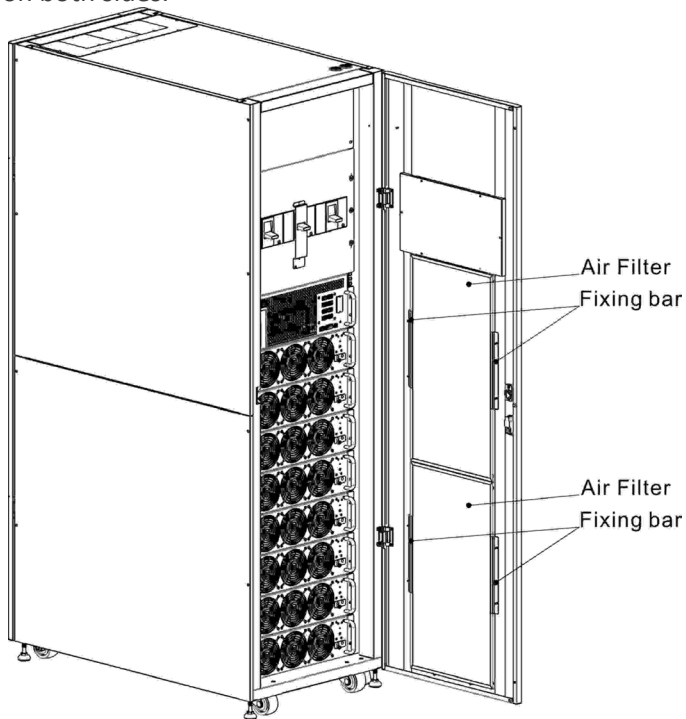

The replacement procedures of air filter are as follows:

1. Open the front door of the UPS. The air filters are on the rear of the door.
2. Remove a fixing bar on either side of the air filter.
3. Remove the air filter, and insert a clean one.
4. Replace the fixing bar.

M90U-80 Specifications

MODEL NUMBER		M90U80-20k	M90U80-40k	M90U80-60k	M90U80-80k
CAPACITY	Power rating	20kVA/20kW	40kVA/40kW	60kVA/60kW	80kVA/80kW
	Enclosure capacity: power modules	Up to 80KVA (4 x 20KVA) or up to 60kVA (4 x 15KVA)			
	Enclosure capacity: battery modules	4, 8, 12, or 16 internal battery modules			
INPUT	Voltage / frequency nominal	208/120V, 50/60Hz auto-sensing			
	Voltage / frequency range	121–253VAC* (L-L), 40–70Hz			
OUTPUT	Voltage	208/120V			
	Frequency	50/60Hz ± 0.5Hz			
	THD (full load)	< 2%			
	Efficiency	Up to 94% online mode or 98% ECO mode			
	Overload capacity	105%-110% for 60min; 110%-125% for 10min; 126%-150% for 1min; >150% for 200ms			
BATTERY SYSTEM	Nominal voltage	± 120V			
	Charge Current (programable)	8A	16A	24A	32A
DIMENSIONS & WEIGHT	Enclosure	23.6"W x 43.3"D x 79.1"H / 657 lbs			
	Power module	19.5"W x 29.5"D x 5.5"H / 74 lbs			
	Battery module	4.3"W x 28.5"D x 6.5"H / 70 lbs			
ENVIRONMENT	Temperature	0–40°C (32–104°F)**			
	Altitude	5,200 ft above sea level**			
	Audible noise	< 65dBA at 1m			
APPROVALS	UL-1778 (TUV), cUL (TUV), FCC A, RoHS, TAA				
WARRANTY	2 years (USA and Canada)				
COMMUNICATIONS INTERFACE	RS-232, EPO, intelligent slot for optional cards (Web/SNMP, Relay, Modbus)				
INCLUDED IN BOX	User manual, RS-232 cable, unloading ramp, ViewPower Software				
AVAILABLE OPTIONS	External maintenance bypass, 480V input transformer, output distribution, battery temperature sensor				

*Depending on load level **Battery life is reduced above 30°C, UPS capacity derates above 30°C and 5,200 ft above sea level

M90U-140 Specifications

MODEL NUMBER		M90U140-20k	M90U140-40k	M90U140-60k	M90U140-80k	M90U140-100k	M90U140-120k	M90U140-140k
CAPACITY	Power rating	20kVA/20kW	40kVA/40kW	60kVA/60kW	80kVA/80kW	100kVA/100kW	120kVA/120kW	140kVA/140kW
	Power modules	Up to 140KVA N+1 (8 x 20KVA) or up to 105kVA N+1 (8 x 15KVA)						
INPUT	Voltage nominal	208/120V						
	Frequency nominal	50/60Hz auto-sensing						
	Voltage range	121–253VAC* (L-L)						
	Frequency range	40–70Hz						
OUTPUT	Voltage	208/120V						
	Frequency	50/60Hz ± 0.5Hz						
	THD (full load)	< 2%						
	Efficiency	Up to 94% online mode or 98% ECO mode						
	Overload capacity	105%-110% for 60min; 110%-125% for 10min; 126%-150% for 1min; >150% for 200ms						
UPS PHYSICAL	Dimensions & weight	23.6"W x 43.3"D x 79.1"H / 657 lbs + 74 lbs per module						
ENVIRONMENT	Temperature	0–40°C (32–104°F)**						
	Altitude	5,200 ft above sea level**						
	Audible noise	< 65dBA at 1m						
BATTERY ENCLOSURE	Charge current (max)	8A	16A	24A	32A	40A	48A	56A
	Dimensions & weight	23.6"W x 43.3"D x 79.1"H / 735 lbs + 85 lbs per module						
	Hot Swappable battery modules (4 per string)	Up to 8 strings with individual breakers						
APPROVALS	UL-1778 (TUV), cUL (TUV), FCC A, RoHS, TAA							
WARRANTY	2 years (USA and Canada)							
COMMUNICATIONS INTERFACE	RS-232, EPO, intelligent slot for optional cards (Web/SNMP, Relay, Modbus)							
INCLUDED IN BOX	User manual, RS-232 cable, unloading ramp, ViewPower Software							
AVAILABLE OPTIONS	External maintenance bypass, 480V input transformer							

*Depending on load level **Battery life is reduced above 30°C, UPS capacity derates above 30°C and 5,200 ft above sea level

Obtaining Service

If the UPS requires Service:

1. Use the TROUBLESHOOTING section in this manual to eliminate obvious causes.
2. Verify there are no circuit breakers tripped.
3. Call your dealer for assistance. If you cannot reach your dealer, or if they cannot resolve the problem, call Xtreme Power Conversion Corp Technical Support at 800.582.4524. Technical support inquiries can also be made at support@xpcc.com. Please have the following information available BEFORE calling the Technical Support Department:
 - Your name and address.
 - The serial number of the unit.
 - Where and when the unit was purchased.
 - All of the model information about your UPS.
 - Any information on the failure, including LED's that may or may not be illuminated.
 - A description of the protected equipment, including model numbers if possible.
 - A technician will ask you for the above information and, if possible, help solve your problem over the phone. In the event that the unit requires factory service, the technician will issue you a Return Material Authorization number (RMA).

If you are returning the UPS or modules to Xtreme Power for service, please follow these procedures:

1. Pack the UPS in its original packaging. If the original packaging is no longer available, ask the Technical Support Technician about obtaining a replacement set of packaging material. It is important to pack the UPS properly in order to avoid damage in transit. Never use Styrofoam beads for a packing material.
2. Include a letter with your name, address, daytime phone number, RMA number, and a brief description of the problem.
3. Mark the RMA number on the outside of all packages. Xtreme Power cannot accept any package without the RMA number marked on the outside of the boxes.
4. Return the UPS by insured, prepaid carrier to the address provided by the Technician.
5. Refer to the Warranty statements in this manual for additional details on what is covered.

Xtreme Power Conversion M90U-80 & M90U-140 Limited Warranty

Xtreme Power Conversion (XPC) Corporation warrants Xtreme Power Conversion equipment, when properly applied and operated within specified conditions, against faulty materials or workmanship for a period of two years for M90U-Series products from the date of purchase. XPC Corporation warrants internal batteries for a period of two years from the date of purchase. For equipment sites within the United States and Canada, this warranty covers repair or replacement, at the sole discretion of XPC Corporation. The customer is responsible for the costs of shipping the defective product to XPC Corporation. XPC Corporation will pay for ground shipment of the repaired or replacement product. The limited warranty does not cover on-site labor. This warranty applies only to the original purchaser. Warranty void if equipment is commissioned by non-factory trained personnel.

If equipment provided by XPC Corporation is found to be Dead-on-Arrival (DOA), the customer must request and receive a Return Material Authorization (RMA) number. DOA equipment is defined as equipment that does not properly function according to user documentation when initially received and connected in conjunction with proper procedures as shown in the user documentation or via support provided by XPC Corporation personnel or authorized agents.

This warranty shall be void if (a) the equipment is repaired or modified by anyone other than XPC Corporation or a XPC Corporation approved third party; (b) the equipment is damaged by the customer, is improperly used or stored, is subjected to an adverse operating environment, or is operated outside the limits of its electrical specifications; or (c) the equipment has been used or stored in a manner contrary to the equipment's operating manual, intended use or other written instructions; or (d) the equipment is damaged due to improper installation or startup. Any technical advice furnished by XPC Corporation or a XPC Corporation authorized representative before or after delivery with regard to the use or application of Xtreme Power Conversion equipment is furnished on the basis that it represents XPC Corporation's best judgment under the situation and circumstances, but it is used at the recipient's sole risk.

EXCEPT AS STATED ABOVE, XPC Corporation DISCLAIMS ALL WARRANTIES, EXPRESSED OR IMPLIED, INCLUDING WARRANTIES OF MERCHANTABILITY AND FITNESS FOR A PARTICULAR PURPOSE.

EXCEPT AS STATED ABOVE, IN NO EVENT WILL XPC Corporation BE LIABLE FOR DIRECT, INDIRECT, SPECIAL, INCIDENTAL, OR CONSEQUENTIAL DAMAGES ARISING OUT OF THE USE OF Xtreme Power Conversion EQUIPMENT, including but not limited to, any costs, lost profits or revenue, loss of equipment, loss of use of equipment, loss of software, loss of data, cost of substitutes, or claims by third parties. Purchaser's sole and exclusive remedy for breach of any warranty, expressed or implied, concerning Xtreme Power Conversion equipment, and the only obligation of XPC Corporation under this warranty, shall be the repair or replacement of defective equipment, components, or parts; or, at XPC Corporation's sole discretion, refund of the purchase price or substitution of an equivalent replacement product.