



XPRT 6kVA & 10kVA Online UPS

6kVA, 10kVA Models

User & Installation Manual

Table of Contents

EMC Statements - FCC Part 15.....	5
Safety Warnings And Symbols.....	5
Safety Warnings.....	5
Safety Symbols.....	6
General.....	6
Transport/Storage.....	7
Maintenance And Servicing.....	7
Introduction.....	8
Product Description.....	8
Double Conversion On-Line Technology.....	8
Efficiency Optimizer Function.....	9
Free Run Mode.....	9
Diagnostic Tests.....	9
System Configuration.....	10
Hardware Installation Guide.....	15
Safety Information.....	15
Installation Procedures.....	16
Connecting Internal Battery Pack (6kVA Model).....	19
Connecting Internal Battery Pack (10kVA Model).....	21
Connecting Additional External Battery Packs (6kVA Model).....	22
Connecting Additional External Battery Packs (10kVA Model).....	24
Connecting Interface Devices.....	27
Standard Hardwired Installation Procedure.....	29
Optional Power Distribution Units.....	32
Startup.....	34
Startup 6kVA UPS.....	34
Startup 10kVA UPS (stand-alone not parallel systems).....	35
Operation.....	36

Normal Operation Conditions.....36

Switching the UPS OFF.....37

Maintenance Bypass.....38

10kVA Parallel Installation And Operation.....40

Installation of a Parallel System.....40

Installing the Parallel Connection.....41

Startup 10kVA UPS Parallel System.....43

Normal Operation Conditions.....43

Switching the UPS OFF.....43

Status and Alarm Indications.....45

On Bypass.....45

On Battery.....46

Battery Low (end of runtime).....46

Bypass Out of Limits.....46

Overload.....46

Replace Battery.....47

Alarm Priority.....47

Fault Mode.....48

Standby.....48

Remote Emergency Power Off (REPO).....48

No Load Shutdown.....49

Auto Restart.....49

Battery Management.....50

Battery Connection Test.....50

Quick Battery Test..... 50

Deep Battery Test.....50

Communication.....50

RS-232 Communication Port.....50

SNMP Interface Card (Option).....51

Extended Runtime.....51

Maintenance.....52

 Safety.....52

 General.....52

 Recycling the UPS at the End of Service Life.....52

 Batteries.....53

 Internal Battery Replacement – 6kVA Model.....53

 Internal Battery Replacement – 10kVA Model.....54

 Power Unit Maintenance.....56

 Power Unit Replacement – 6kVA Model.....56

 Power Unit Replacement – 10kVA Model.....56

Troubleshooting.....58

Specifications.....59

Shipping List..... 59

Obtaining Service.....60

Xtreme Power Conversion Limited Warranty.....61

Xtreme Power Conversion Load Protection Policy.....62

Appendix A: SNMP/WEB Card (Optional).....65

 Introduction.....65

 LEDs..... 65

 Features.....65

 Architecture.....66

 Interfaces.....67

 Configuration.....67

 Access.....69

Thank you for selecting this uninterruptible power supply (UPS). It provides you with protection for connected equipment. Please read this manual before installing the XPRT-Series UPS models XPRT-6000 and XPRT-10000 as it provides important information that should be followed during installation and maintenance of the UPS and batteries, allowing you to correctly set up your system for the maximum safety and performance. Included is information on customer support and service, if it is required. If you experience a problem with the UPS, please refer to the Troubleshooting section in this manual to correct the problem. If the problem is not corrected, please collect information so that the Technical Support personnel can more effectively assist you.

EMC Statements - FCC Part 15

Notice: This equipment has been tested and found to comply with the limits for a Class A digital device, pursuant to Part 15 of the FCC Rules. These limits are designed to provide reasonable protection against harmful interference when the equipment is operated in a commercial environment. This equipment generates, uses, and can radiate radio frequency energy and, if not installed and used in accordance with the instruction manual, may cause harmful interference to radio communications. Operation of this equipment in a residential area is likely to cause harmful interference in which case the user will be required to correct the interference at the users own expense.

Modifications not expressly approved by the manufacturer could void the user's authority to operate the equipment under FCC rules.

IMPORTANT SAFETY INSTRUCTIONS: (SAVE THESE INSTRUCTIONS)

This manual contains important instructions that should be followed during installation and maintenance of the UPS. It also gives all necessary information about the correct use of the UPS. Before attempting to install and start up the UPS, carefully read this manual. Keep this manual next to the unit for future references.

Full understanding of and compliance with the safety instructions and warnings contained in this manual are the **ONLY CONDITIONS** to avoid any dangerous situation during installation, operation and maintenance work, and to preserve the maximum reliability of the UPS system.

Xtreme Power Conversion (XPC) Corp refuses any responsibility in case of non-observance, unauthorized alterations, or improper use of the delivered UPS.

While every care has been taken to ensure the completeness and accuracy of this manual, XPC accepts no responsibility or liability for any loss or damage resulting from the use of the information contained in this document. This document shall not be copied nor reproduced without the permission of XPC.

Due to technical improvements, some of the information contained in this manual may be changed without notice.

The instructions in this manual are for UPS models XPRT-6000 and XPRT-10000. Check your model number by looking at the top cover of your UPS. Any difference in instructions is clearly indicated in the text (for instance 'XPRT-10000').

Safety Warnings And Symbols

Safety Warnings

The text of this manual contains warnings to avoid risk to persons and to avoid damages to the UPS system and the supplied critical loads. Do not proceed beyond these warnings if you do not fully understand and/or are not able to meet the mentioned conditions.

The non-observance of the warnings reminding hazardous situations could result in human injury and equipment damage.

Please pay attention to the meaning of the following warnings and symbols.

**WARNING!**

Refers to procedures or operations which, when not correctly performed, could cause personal injury or serious damage to the system.

**NOTE**

Warns the user about important operations or procedures described in this manual.

Safety Symbols

**CAUTION**

The product may be in danger: when procedures or operations are not correctly performed, damage to the product may be the result.

**DANGER OF ELECTRICALLY LIVE PARTS**

Related to all situations with potentially hazardous voltage.

**NOTE**

Check for sufficient floor and elevator loading capacity. Move the UPS and the battery pack in its original package to the final destination room. Do not stack other package on top.

**WARNING!**

Pay attention to the **HEAVY WEIGHT** of the UPS when downloading the UPS from the pallet! Never try to lift the unit by yourself!

General

**DANGER! RISK OF ELECTRIC SHOCK.**

The UPS has an internal battery supply with a nominal voltage of 144VDC (6kVA) 288VDC (10kVA). Some of the parts of the UPS are necessarily under a hazardous voltage. Do not open the unit; there are no user serviceable parts inside. The outlets and output terminals may be electrically live, even when the UPS is disconnected from the utility power.

**CAUTION**

There may be damage to the equipment if procedures and practices are not strictly observed and followed.

Transport/Storage



NOTE

Check for sufficient floor and elevator loading capacity. Move the UPS and the battery pack in its original package to the final destination room. Do not stack other package on top.



WARNING!

Pay attention to the HEAVY WEIGHT of the UPS when removing the UPS from the pallet! Never try to lift the unit by yourself!

No liability can be accepted for any transport damage when the equipment is not shipped in original packaging. Store the UPS in a dry location with the batteries in a fully charged state. Storage temperature must be within -20 +45°C (-4°F and 113°F). If the unit is stored for a period exceeding 3 months, optimal battery lifetime is obtained if the storage temperature does not exceed 30°C (86°F).

If the unit is stored for an extended period of time, the batteries must be recharged periodically. Connect the unit to a wall outlet and recharge the batteries for 24 hours:

- if the storage temperature is within -20 and +30°C (-4°F and 86°F): every 3 months
- if the storage temperature is within -20 and +45°C (-4°F and 113°F): every 1 month



CAUTION

In case of storage, pay attention to:



Maintenance And Servicing

- All maintenance and servicing, except replacement of the batteries and plug-in cards, is to be carried out by qualified skilled personnel only
- A battery can present a risk of electrical shock and high short circuit current
- Never dispose of batteries in a fire: they may explode
- Do not open or mutilate batteries: their contents may be extremely toxic. If exposed to electrolyte, wash immediately with plenty of water
- The batteries must be disconnected during maintenance or service work
- When replacing the batteries, use only the same type and size battery
- The following precautions should be observed when working on batteries:
 - Remove watches, rings or other metal objects
 - Use tools with insulated handles
 - Wear rubber gloves and boots
 - Do not lay tools or metal parts on top of batteries
 - Disconnect charging source prior to connecting or disconnect battery terminals
 - Determine if the battery is inadvertently grounded. If inadvertently grounded, remove source of ground. Contact with any part of a grounded battery can result in electrical shock. The likelihood of such shock will be reduced if such grounds are removed during installation and maintenance.
- Avoid charging in a sealed container

**NOTE**

Do not attempt to service the UPS unless you have had proper training. Refer all maintenance and servicing, except replacement of the batteries, power unit (10kVA), and plug-in cards, to properly qualified, skilled, and competent service personnel.

Qualified, skilled personnel are persons who (because of their training, experience, and position as well as their knowledge of appropriate standards, regulations, health and safety requirements and working conditions) are authorized to be responsible for the safety of the equipment, at all times whilst carrying out their normal duties and are therefore aware of, and can report, possible hazards (observe IEC 60364 and national wiring regulations and accident prevention rules).

Introduction

The information provided in this manual covers single phase 6000 and 10000 VA uninterruptible power systems, their basic functions, operating procedures, options available, and emergency situations. It also includes information on how to ship, store, handle, and install the equipment. Only detailed requirements of the UPS units are described herein, and installation must be carried out in accordance with this manual. Electrical installation must also carefully follow local legislation and regulations. Only qualified personnel should conduct these installations as failure to acknowledge electrical hazards could prove to be fatal.

Product Description

Many different kinds of sensitive electrical equipment can be protected by an Uninterruptible Power Supply (UPS) including computers, workstations, process control systems, telecommunications systems, sales terminals, other critical instrumentation, etc. The purpose of the UPS is to protect these systems from poor quality utility power, complete loss of power, or other associated problems.

Electrical interference exists in many forms, causing problems in AC power, from lightning, power company accidents and radio transmission motors, air conditioners, and vending machines. Protection of sensitive electrical equipment is vital to protect against power outages, low or high voltage conditions, slow voltage fluctuations, frequency variations, differential and common-mode noise, transients, etc.

To prevent power line problems from reaching critical systems causing damage to software, hardware, and equipment malfunctions, the UPS maintains constant voltage, isolating critical load output and cleaning the utility AC power.

Double Conversion On-Line Technology

A double conversion on-line technology UPS provides completely isolated, clean, uninterrupted single-phase power to your critical systems, while maintaining the batteries for their maximum potential. In the event that the power failure lasts longer than the UPS backup time, the UPS will shut down avoiding battery damage. When the input AC voltage returns, the UPS will automatically return online to recharge the batteries.

As shown in the block diagram below:

- An input filter reduces transients on the incoming utility.
- To maintain full battery charge, the AC input power is rectified and regulated in the rectifier feeding power to the battery converter and inverter.
- DC power is converted to AC in the inverter, passing it on to the load.
- Power is maintained from the battery during a power failure.
- The converter increases voltage appropriately for the inverter.

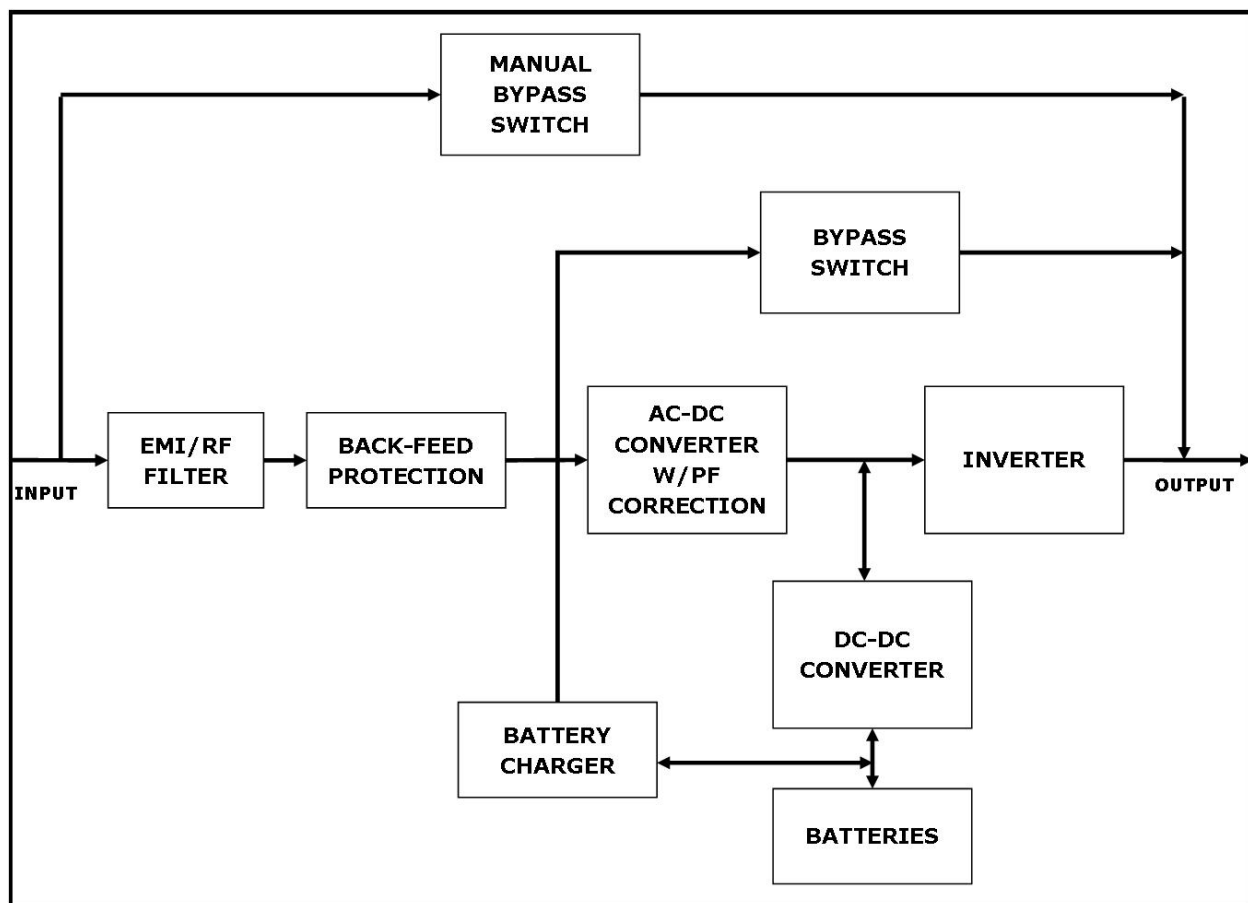

BLOCK DIAGRAM

Efficiency Optimizer Function

The Efficiency Optimizer Function is a new feature for the UPS, adding cost effectiveness, minimizing power loss and reducing power consumption. Alternating between bypass and on-line modes is achieved automatically and in accordance with the conditions of the utility power. On-line mode may be used during times of intermittent power, and bypass mode used when power flows smoothly, in order to obtain greatest efficiency. Irregularities can be detected in less than a second, and on-line mode reactivates immediately. Switching back to on-line mode occurs when input voltage is outside $\pm 10\%$ of nominal ($\pm 15\%$ selectable), when input frequency is outside of $\pm 3\text{Hz}$ or when no input line is available.

Although high efficiency is standard, the default operation is in on-line mode. Bypass can be activated in the LCD panel; though on-line can be run permanently if preferred.

Free Run Mode

The UPS operates in Free Run Mode when input frequency is outside of the selected input frequency range. Free Run Mode is when output frequency does not match input frequency. When starting the UPS, the frequency regulation detected is 50 or 60 Hz $\pm 0.25\text{Hz}$.

Diagnostic Tests

When the UPS is started, a diagnostic test is automatically executed, checking the electronics and batteries, reporting any problems on the LED display.

An Xtreme Battery Management system always monitors the conditions of the batteries, sending any forewarnings if replacement of batteries is required. Every 30 days of normal mode operation, a battery discharge test is automatically performed, reporting any problems on the LED display.

Except during the first 24 hours after startup while the UPS is in charging mode, diagnostic tests can be performed manually from the front panel at any time.

System Configuration

The UPS device and the internal batteries make up the system. Depending on the site and load requirements of the installation, certain additional options are available for the solution.

Planning a UPS system, the following should be taken into consideration:

- The total demand of the protected system shall dictate the output power rating (VA). Allow a margin for future expansion or calculation inaccuracies from measured power requirements.
- Backup time required will indicate the battery size needed. If the load is less than the UPS nominal power rating, then actual backup time is longer.
- The following options are available:
 - Extended Battery Packs (maximum of 3 battery packs of same model)
 - XPRT-BP4-90000019 for 6000
 - XPRT-BP5-90000030 for 10000
 - Connectivity Options –SNMP/WEB card
 - XPRT-SNMP2-90000031
 - 4-Post Mounting Rail Kit
 - XPRT-RR2-90000032
 - 10kVA Power Distribution Unit e/w (8)5-20R+(2)L5-20R+(2)L6-30R
 - XPRT-PDU3-90000035
 - Power Distribution Units for additional receptacles
 - XPD1420HV-90000045 provides 12FT 5-20P INPUT + (14)5-20R
 - XPD1420HVA-90000050 provides 12FT 5-20P INPUT + (14)5-20R + AMP METER

See the Specification section of this manual for addition model information.



6kVA FRONT VIEW



6kVA FRONT VIEW

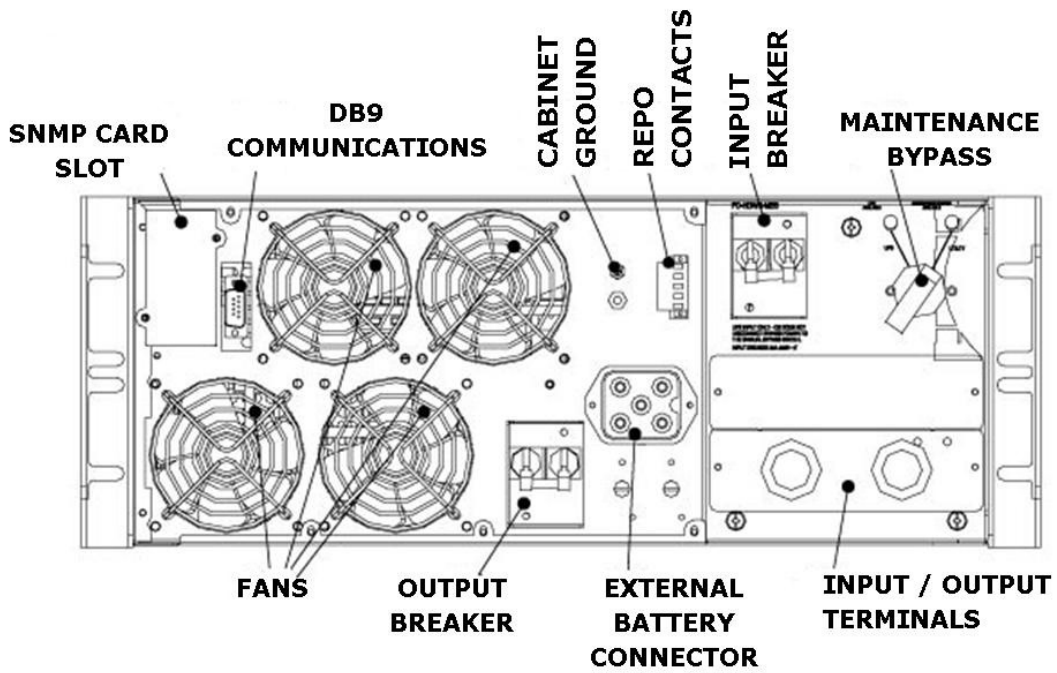

XPRT-6000HB-90000036 BUNDLE REAR VIEW
(WITH UPS, INTERNAL BATTERY & HARDWIRE PDU)

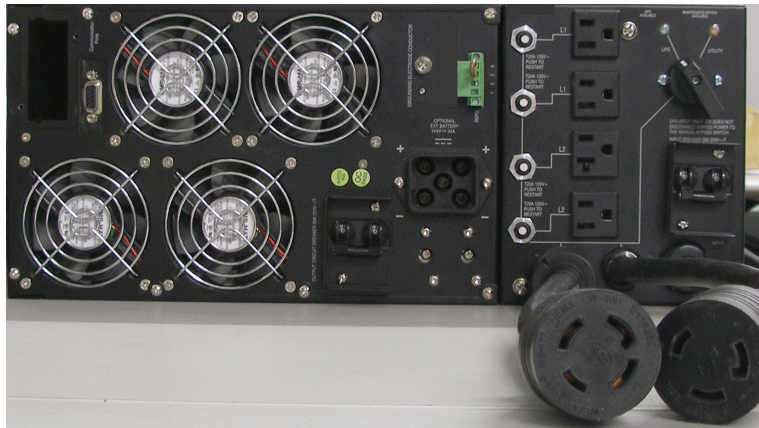

**XPRT-6000B-9000013 BUNDLE REAR VIEW
(WITH UPS, INTERNAL BATTERY & RECEPTACLE PDU (4) 5-20R + (1) L6-30R + (1) L14-30R)**

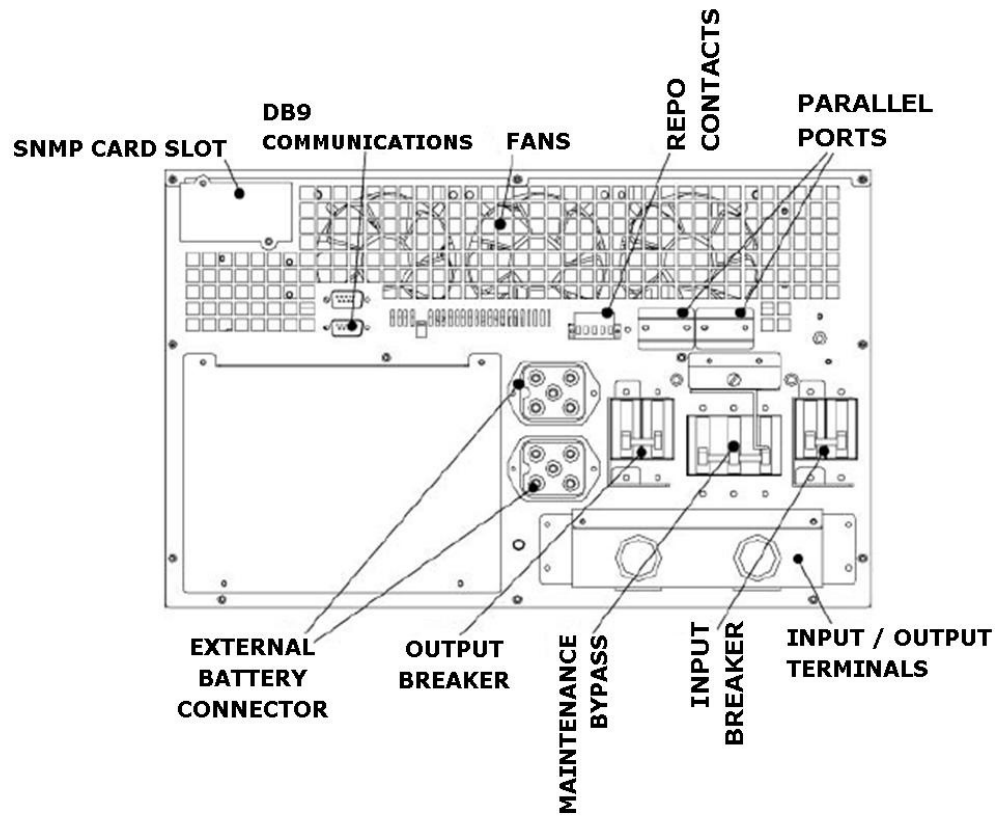

**XPRT-10000B-9000014 REAR VIEW
(STANDARD HARDWIRE + INTERNAL BATTERIES)**

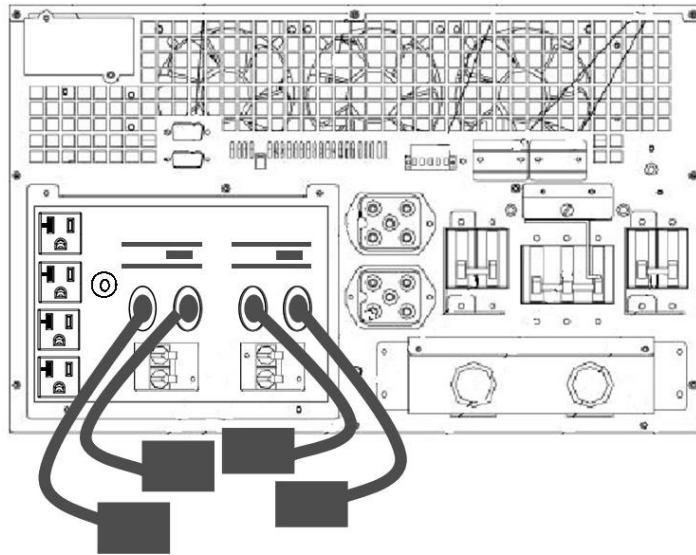

XPRT-10000-90000016 + XPRT-PDU3-90000035 REAR VIEW
(W/ PDU (4) 5-20R + (2) L5-20R + (2) L6-30R)

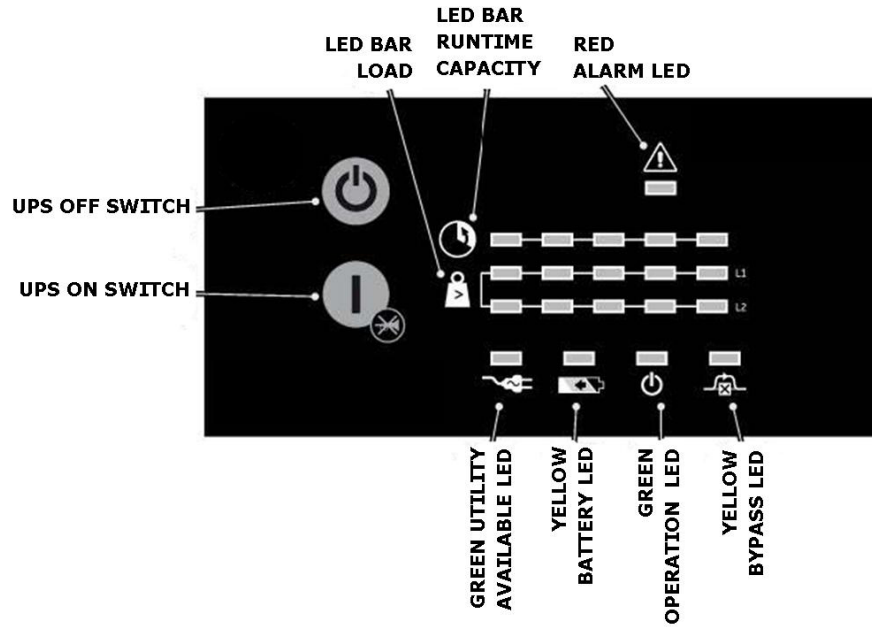

FRONT PANEL – HORIZONTAL

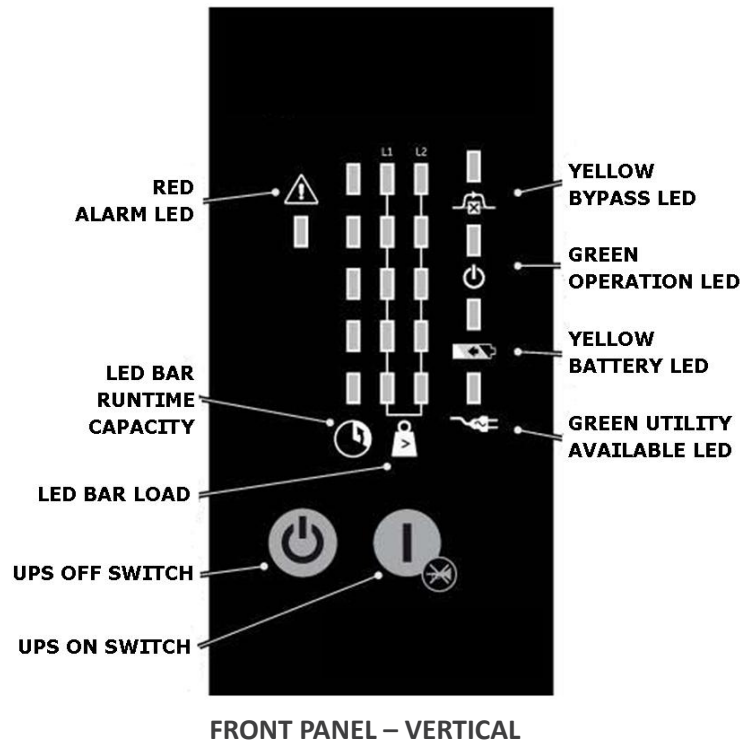
**UPS Off Switch**

Switches the UPS from normal operation to bypass and from bypass or battery to standby

UPS On Switch

Switches on the UPS, starts quick battery test, mute the buzzer

Green Utility Available LED

Indicates availability of utility input power

Yellow Battery LED

This LED will be in during on-battery operation: the utility input power fails, and the internal batteries (and external battery packs if available) supply the power until either the batteries are depleted or the utility input power returns

Green Operation LED

This LED will be on when the output is supplied by the UPS (not on bypass)

Yellow Bypass LED

This LED will be on when the UPS operates in Bypass Mode: the utility input power is passing directly to the load. If this LED blinks, then the input voltage is out of bypass tolerance

Red Alarm LED

This LED is on in case of an alarm

LED Bar Runtime Capacity (Green)

These LEDs indicate the remaining available battery runtime for the actual load in % of the maximum runtime. When the Alarm LED is on, this bar may show a combination of LEDs, describing the Alarm cause.

1 LED = 0-20%

2 LEDs = 21-40%

- 3 LEDs = 41-60%
- 4 LEDs = 61-80%
- 5 LEDs = 81-100%

LED Bar Load (Green or Yellow)

These LEDs indicate to what extent the output capacity of the UPS is used by the actual load for each output line (L1 and L2). If for example, the 25%, 50%, and 75% LEDs are on for Line 1, and the 25% and 50% LEDs are on for Line 2, the load exceeds 50% of the maximum load for Line 1 and 25% of the maximum load for Line 2. If all 5 LEDs are on, the unit operates in overload. As this is an abnormal situation, the alarm LED will also be on.

- 1 LED = 0-25% Green
- 2 LEDs = 26-50% Green
- 3 LEDs = 51-75% Green
- 4 LEDs = 76-100% Green
- 5 LEDs = >100% Yellow

Remote Emergency Power Off (EPO) Port

A customer supplied switch located remotely can be used to open the EPO connection and allows the UPS output receptacles to be switched off. Since the EPO shuts down the equipment immediately, orderly shutdown procedures are not followed by any power management software. The UPS will have to be manually restarted in order to regain power to the outlets on the UPS.

Hardware Installation Guide

Inspect the UPS for damage after unpacking. If any damage is present please immediately notify the carrier and place of purchase.



NOTE

The internal battery packs for these UPS ship separately. FOR the 6kVA model there is 1 internal battery pack, and for the 10kVA model there are 2 internal battery packs are shipped separately.



WARNING! In case of recognizable damage:

DO NOT connect any voltage to the unit
DO NOT put the unit into operation

Safety Information

Information presented here is vital to all personnel. Please read all Safety information.



IMPORTANT

Before making any connection and switching on the XPRT Series UPS, please check the following conditions:

- All electrical connections are to be realized by qualified skilled personnel only.
- To avoid potential health risks, electrical components should not be mechanically damaged or destroyed. Do not touch electronic components. They may be electrostatic sensitive and are for that reason easily damaged due to improper handling.
- Avoid locations that are excessively humid, near water, near heat sources or in direct sunlight. It is important that the unit has adequate ventilation. Maintain air movement around and through the unit. Do not

block the air vents.

- The ambient temperature should not exceed 40°C(104°F). Optimal battery lifetime is obtained if the ambient temperature does not exceed 30°C (86°F).
- Avoid spilling liquids or dropping any foreign object into the UPS.
- The UPS should only be powered from a two phase, four wire AC source equipped with neutral and earth connection. The input utility is 100 - 127 Volts (Line-N) and 60 Hz (if the input utility frequency is 50Hz, the output frequency of the UPS can be changed).
- The total power demand of the connected equipment does not exceed the rated output power of the XPRT Series UPS

CAUTION

A disconnect switch shall be provided by others for ac input and output circuit. To reduce the risk of fire, connect only to a circuit provided with a branch circuit overcurrent protection for 60 amperes rating in accordance with the National Electric Code, ANSI/NFPA 70. (For model XPRT-10000)



A disconnect switch shall be provided by others for ac input and output circuit. To reduce the risk of fire, connect only to a circuit provided with a branch circuit overcurrent protection for 30 amperes rating in accordance with the National Electric Code, ANSI/NFPA 70. (For model XPRT-6000)



CAUTION

To reduce risk of fire, connect the UPS only to a circuit provided with fuse or circuit breaker values as shown above.

Installation Procedures

The UPS can be used in a standalone tower format using the two supporting stands, or can be mounted in a 19 inch rack using the mounting brackets. Proceed to the corresponding section, and then connect internal batteries. All required items are included in the delivery, except rails – available as rail kit option.



NOTE

The UPS output receptacles and/or terminals are live as soon as the UPS is connected to input utility power, even if the UPS has not been switched on via the front panel.

Tower Installation

1. Place the UPS cabinet horizontally on a flat surface.
2. Assemble the plastic support feet and mount them to UPS bottom
3. Place the cabinet upright and mount top covers
4. Attach the display sticker

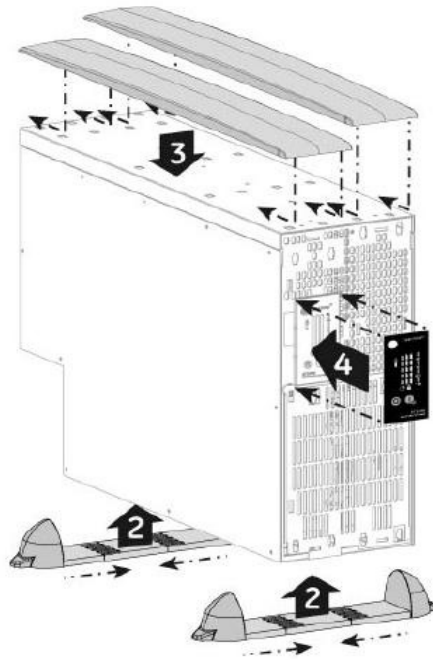

XPRT-6KVA TOWER ASSEMBLY

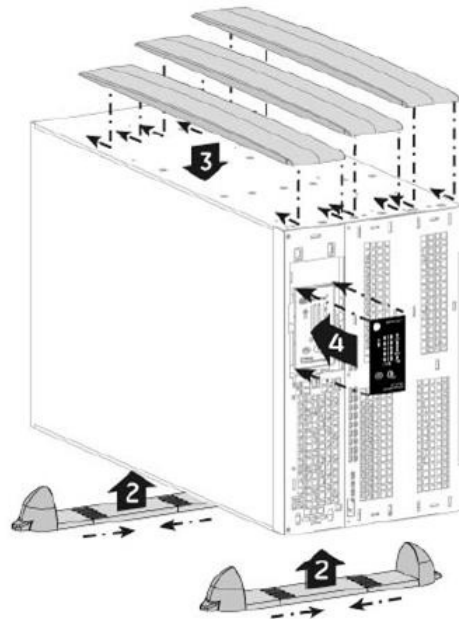

XPRT-10KVA TOWER ASSEMBLY

The XPRT Series UPS is now ready for further connection; proceed with internal battery connection.

Rack Mount Installation

1. Place the UPS cabinet horizontally on a flat surface.
2. Install the mounting brackets that came with the unit using the provided screws
3. Install the UPS into a 19' rack. The UPS cabinet must be supported by mounting rails, do not mount it by using the mounting brackets only.

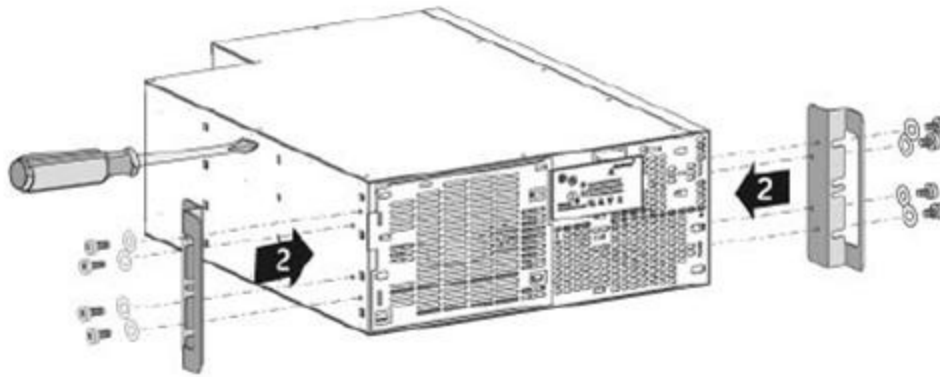

XPRT-6KVA RACK MOUNT ASSEMBLY

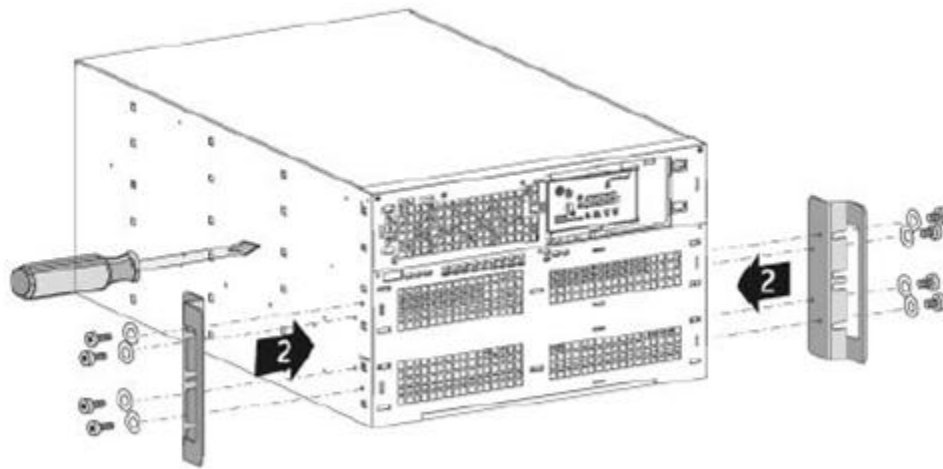

XPRT-10KVA RACK MOUNT ASSEMBLY



NOTE

Please consider the weight of the UPS prior to installation to ensure the rack and floor is capable of supporting the weight. For rack installation we recommend that the UPS is placed in the lower section of the rack. Fit the unit and the battery into the rack cabinet with the help of a second person.

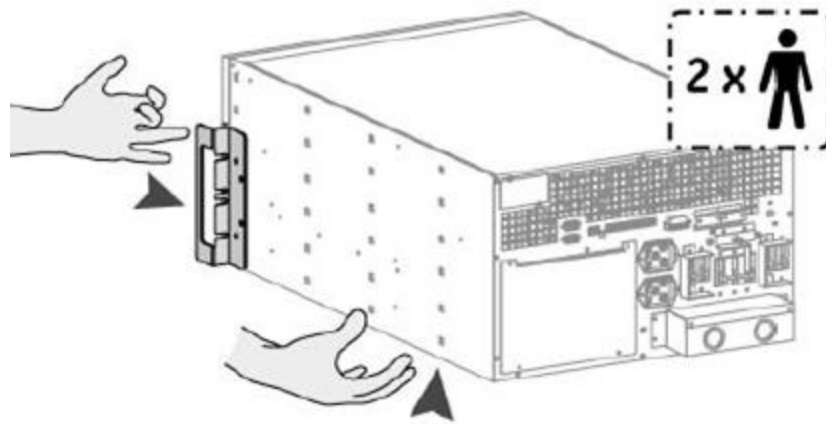

XPRT 6-10KVA RACK MOUNT ASSEMBLY



XPRT 6-10KVA RACK MOUNT ASSEMBLY

The XPRT Series UPS is now ready for further connection; proceed with internal battery connection.

Connecting Internal Battery Pack (6kVA Model)

The internal battery pack is shipped separately from the UPS cabinet. It has to be mounted inside the unit before the UPS installation. Please proceed with the following steps:

1. Unpack the battery pack from its container.
2. Place the battery pack in front of the battery compartment, aligning the rear connector to the front panel.
3. Slide the battery pack into the battery compartment until the rear connector is plugged with the UPS internal DC socket.
4. Fix the battery cover by tightening screws.
5. Mount the front panels by pushing the plastic part into the appropriate holes.
6. Proceed with the UPS installation.

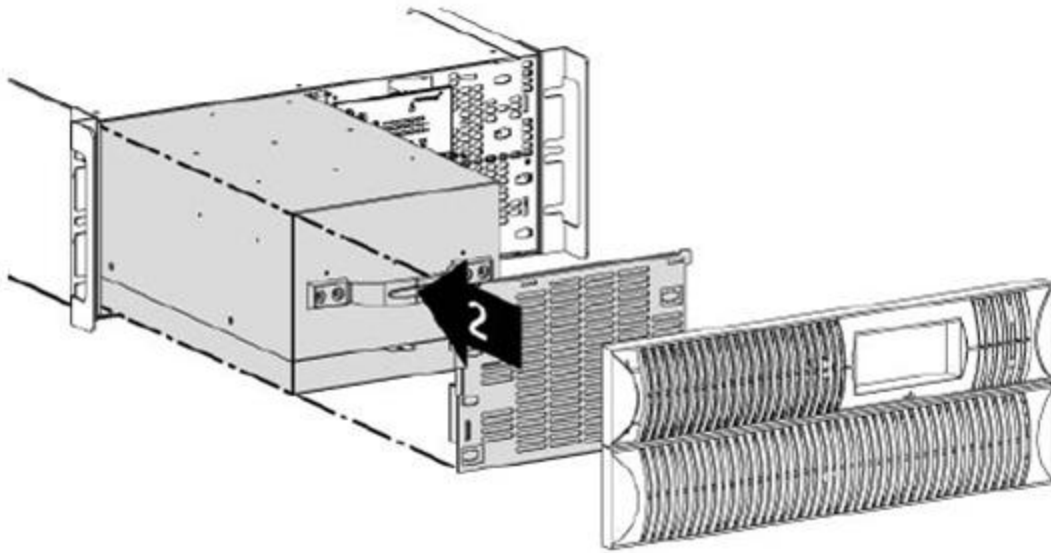

XPRT-6KVA SLIDE BATTERY PACK INTO UPS

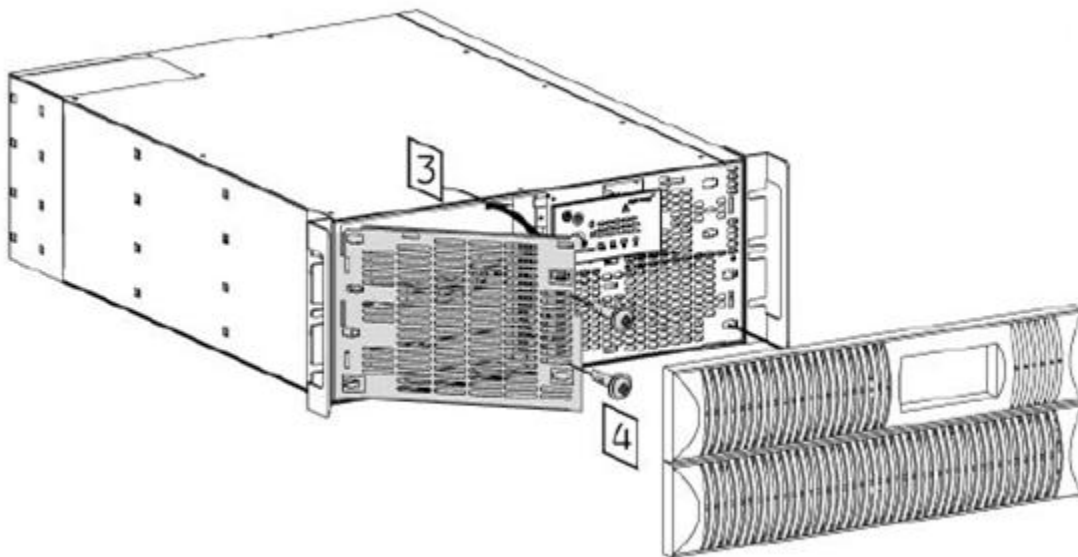

XPRT-6KVA ATTACH BATTERY COVER ON UPS

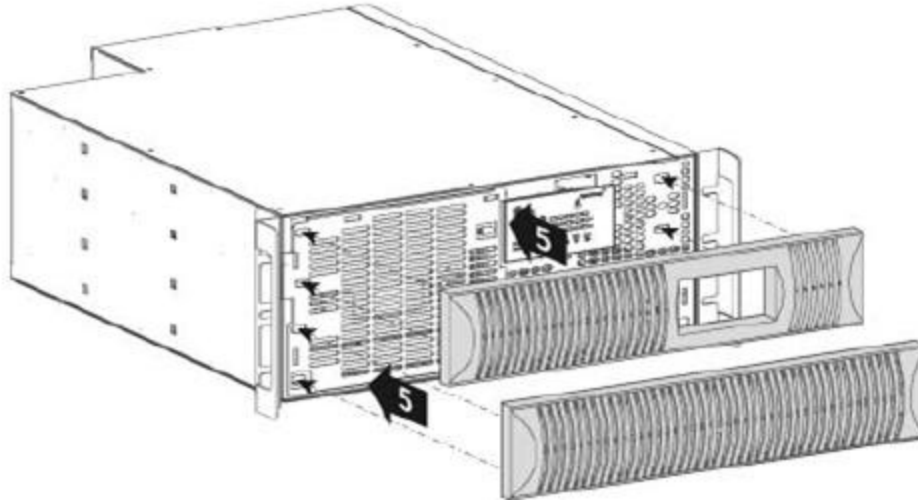

XPRT-6KVA MOUNT PLASTIC FRONT PANELS

Connecting Internal Battery Pack (10kVA Model)

The internal battery packs are shipped separately from the UPS cabinet. They have to be mounted inside the unit before the UPS installation. Please proceed with the following steps:

1. Unpack the two battery packs from its container.
2. Place the battery packs in front of the battery compartment, aligning the rear connector to the front panel.
3. Slide the battery packs into the battery compartment until the rear connector is plugged with the UPS internal DC socket.
4. Fix the battery cover by tightening screws.
5. Mount the front panels by pushing the plastic part into the appropriate holes.
6. Proceed with the UPS installation.

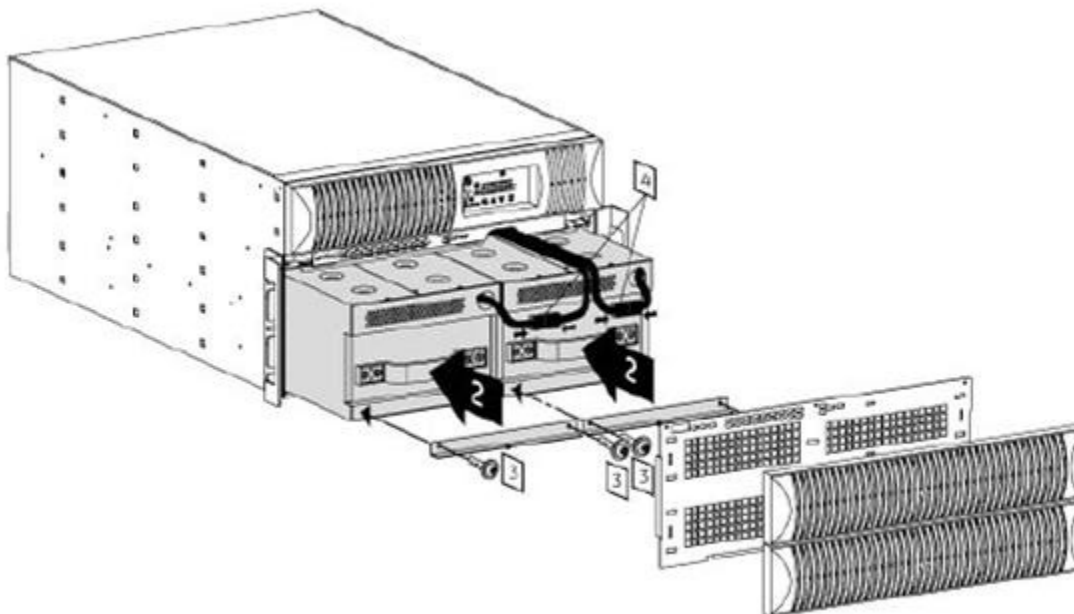

XPRT-10KVA SLIDE BATTERY PACKs INTO UPS

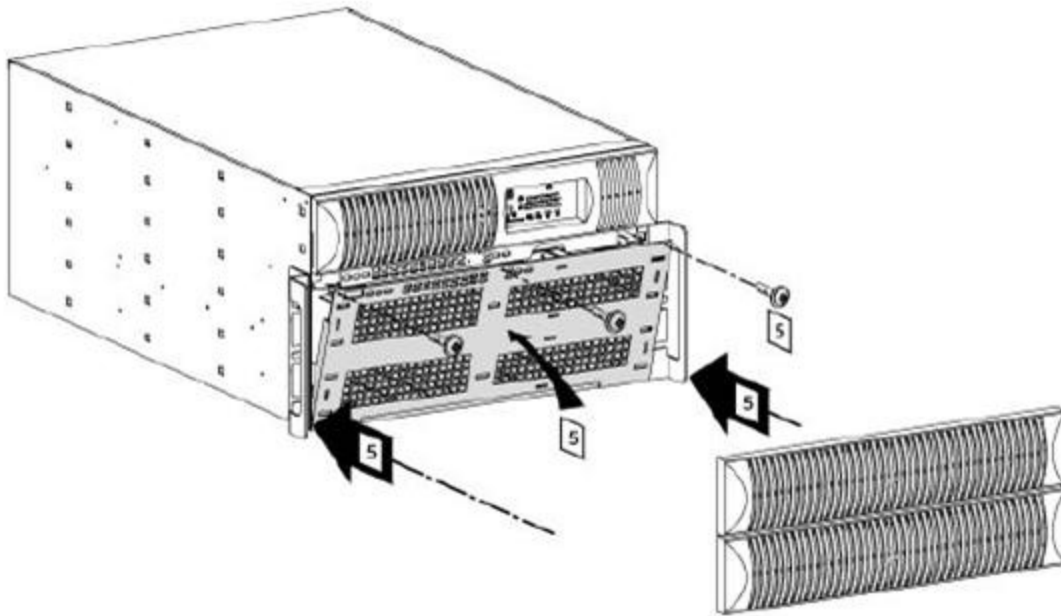

XPRT-10KVA ATTACH BATTERY COVER ON UPS



NOTE

The Battery Cover and Front Panel **MUST** be installed before trying to start the UPS. There is a switch that the Battery Cover activates - if not activated the UPS will not start.

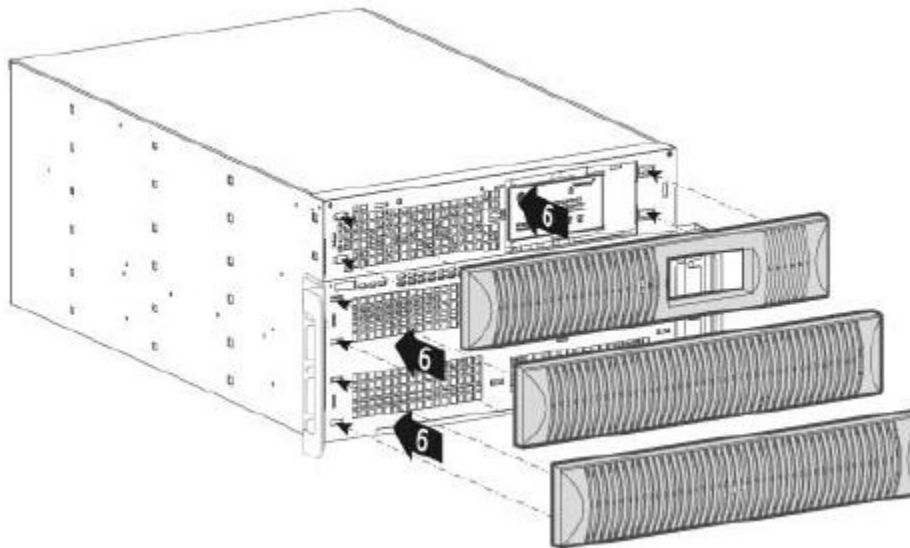

XPRT-10KVA MOUNT PLASTIC FRONT PANELS

Connecting Additional External Battery Packs (6kVA Model)

The additional external battery pack connects to the UPS in the same way whether the UPS is being used in tower or rack mount format.

When used in tower format, the UPS and additional battery packs can be mounted together in one set of mounting supports. Additional supports are shipped with battery cabinet.

Connect the cable provided with the battery between UPS and battery pack – plug it into the UPS battery socket and the nearest battery connection socket on the battery pack.

On first startup the value of the total battery capacity has to be set with the UPS Monitoring software.

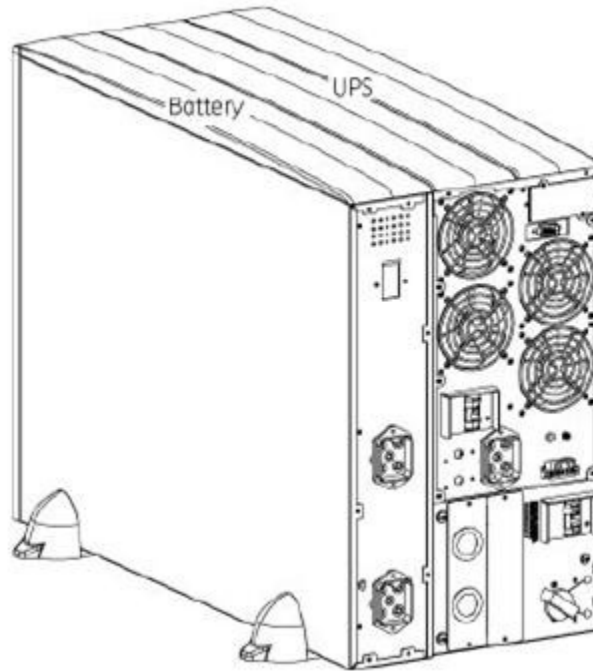

XPRT-6KVA UPS + BATTERY PACK

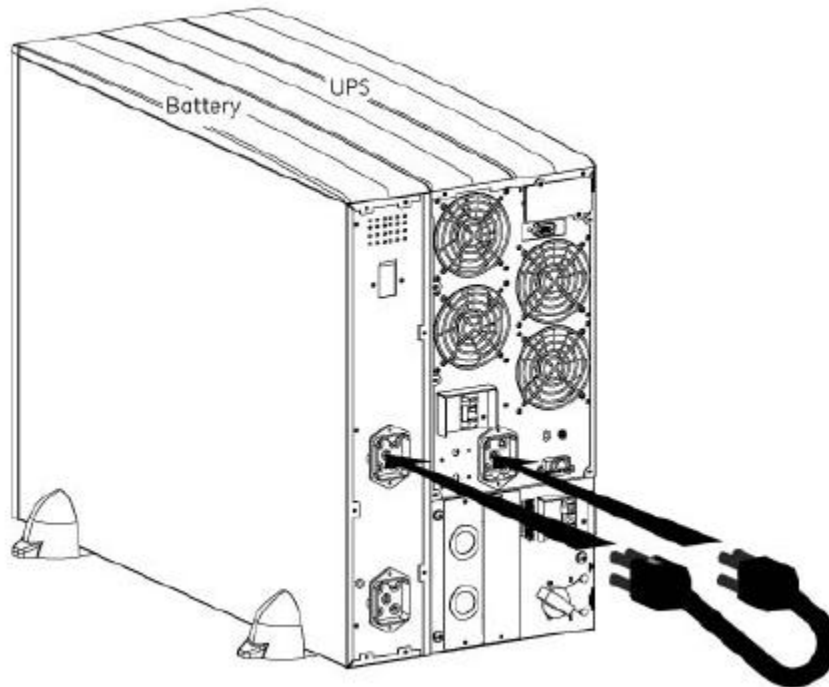

XPRT-6KVA UPS + BATTERY PACK CABLE CONNECTION

**NOTE**

If further battery packs are used, they connect via the previous battery pack. Thus, the cable provided is attached via the nearest socket connection on the existing battery cabinet.

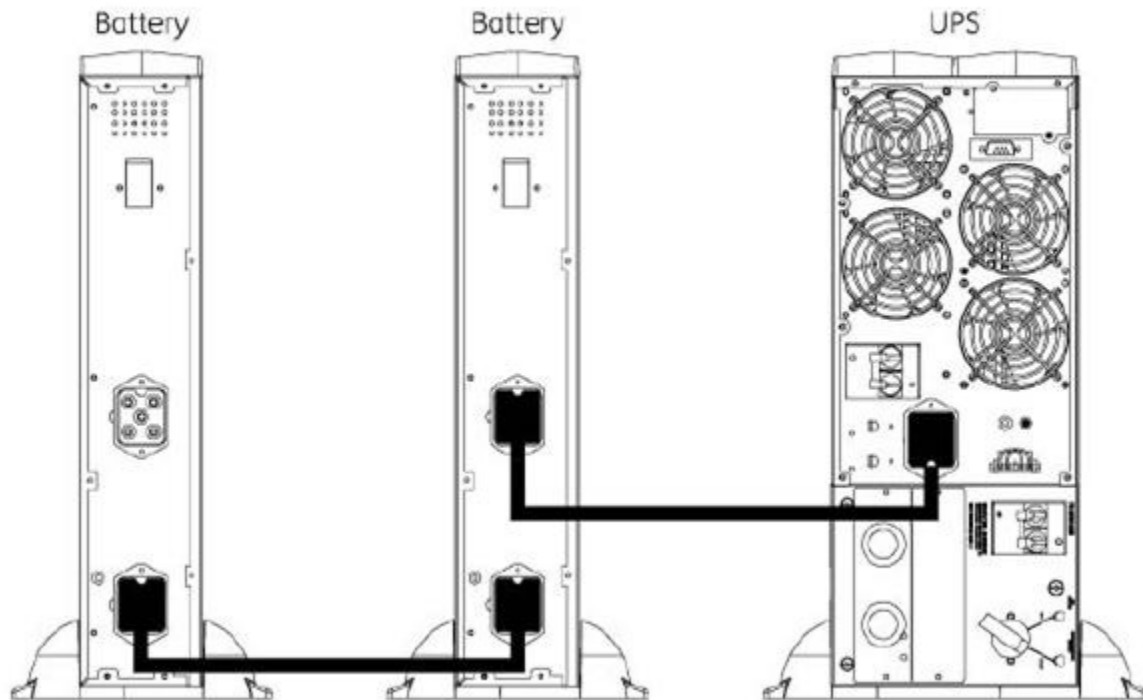

XPRT-6KVA UPS + MULTIPLE BATTERY PACK CABLE CONNECTION

**NOTE**

When the UPS is connected to the input utility, and the battery pack(s) are connected to the UPS, the batteries start charging. For best results, allow the UPS to recharge the batteries during a period of approx. 8 hours. It is acceptable to use the UPS without first charging the battery, but the runtime may be reduced.

Connecting Additional External Battery Packs (10kVA Model)

For the XPRT-BP5 (external battery pack for the XPRT-10kVA) the battery packs are shipped with the battery trays separate from the battery pack. The battery trays need to be mounted inside the battery pack after the battery pack is set in position.

1. Unpack the 2 battery trays from their container
2. Place the battery trays side by side in the battery compartment
3. Fix the 2 battery brackets with the screw set to hold battery trays into the battery pack
4. Connect the DC connectors of each battery tray
5. Install the battery grille in front of the battery compartment with 3 screws
6. Mount the 2 battery pack front covers

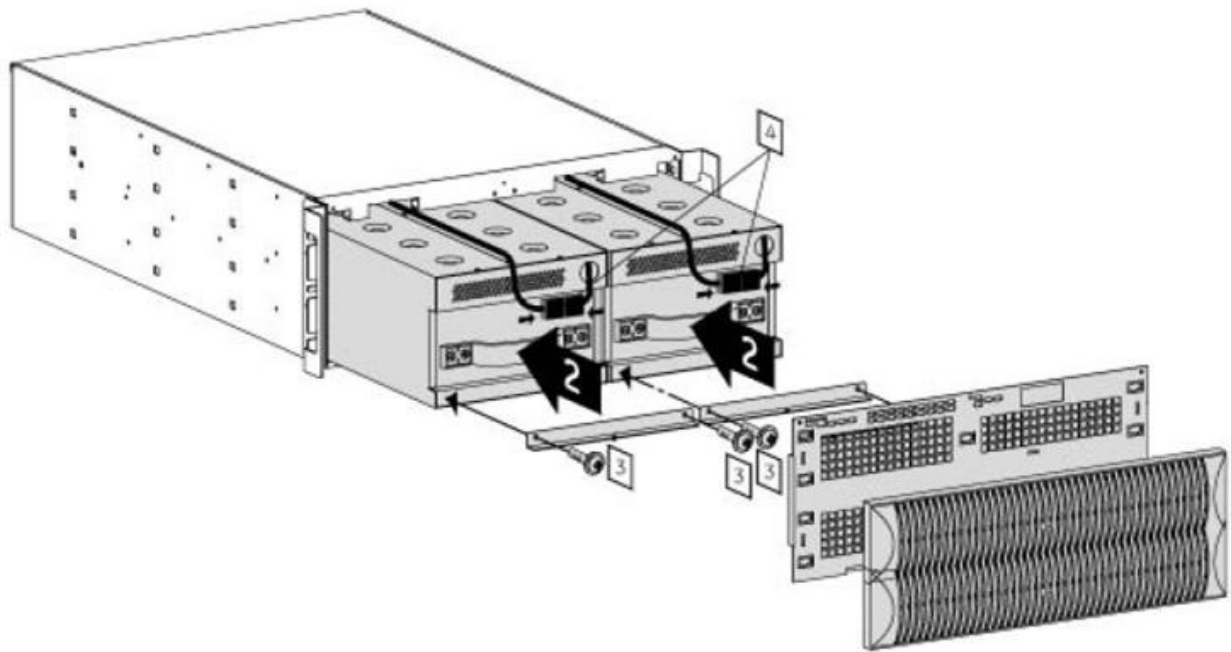

XPRT-10KVA BP5 BATTERY TRAY INSTALLATION

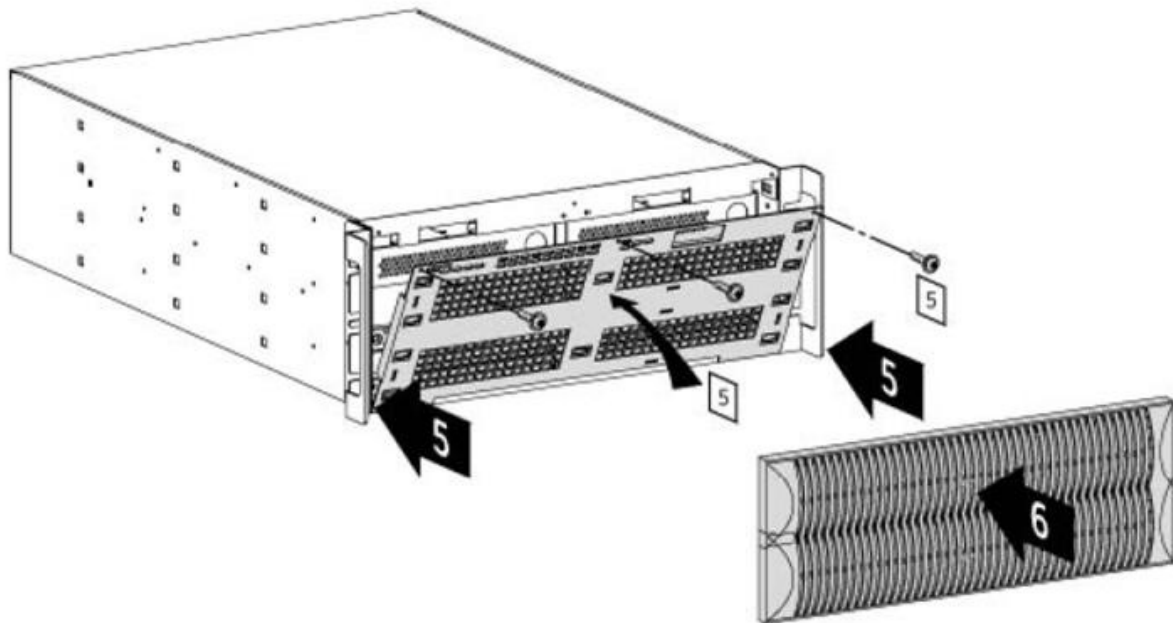

XPRT-10KVA BP5 BATTERY PACK COVER INSTALLATION

The additional external battery pack connects to the UPS in the same way whether the UPS is being used in tower or rack mount format.

When used in tower format, the UPS and additional battery packs can be mounted together in one set of mounting supports.

Connect the cable provided with the battery between UPS and battery pack – plug it into the UPS battery socket and the nearest battery connection socket on the battery pack.

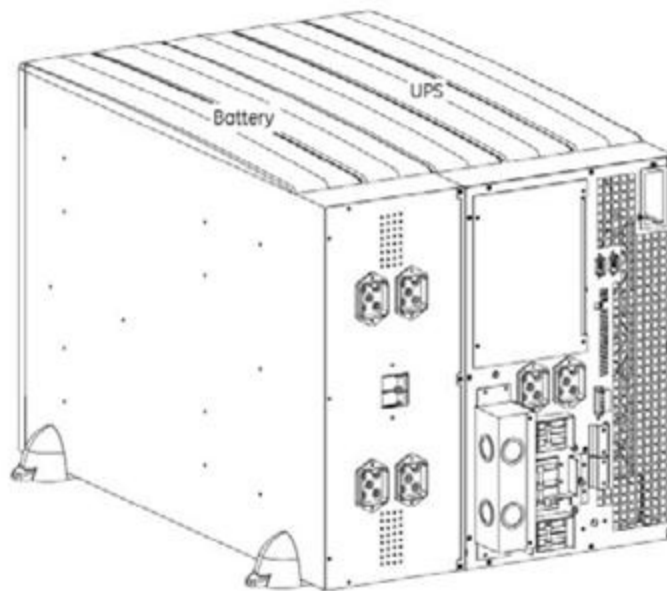

XPRT-10KVA UPS + BP5 TOWER INSTALLATION

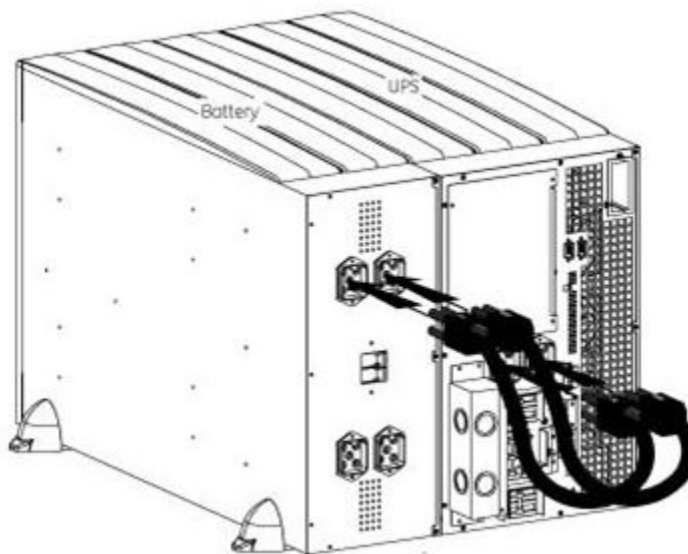

XPRT-10KVA UPS + BP CABLE INSTALLATION



NOTE

If further battery packs are used, they connect via the previous battery pack. Thus, the cable provided is attached via the nearest socket connection on the existing battery cabinet.

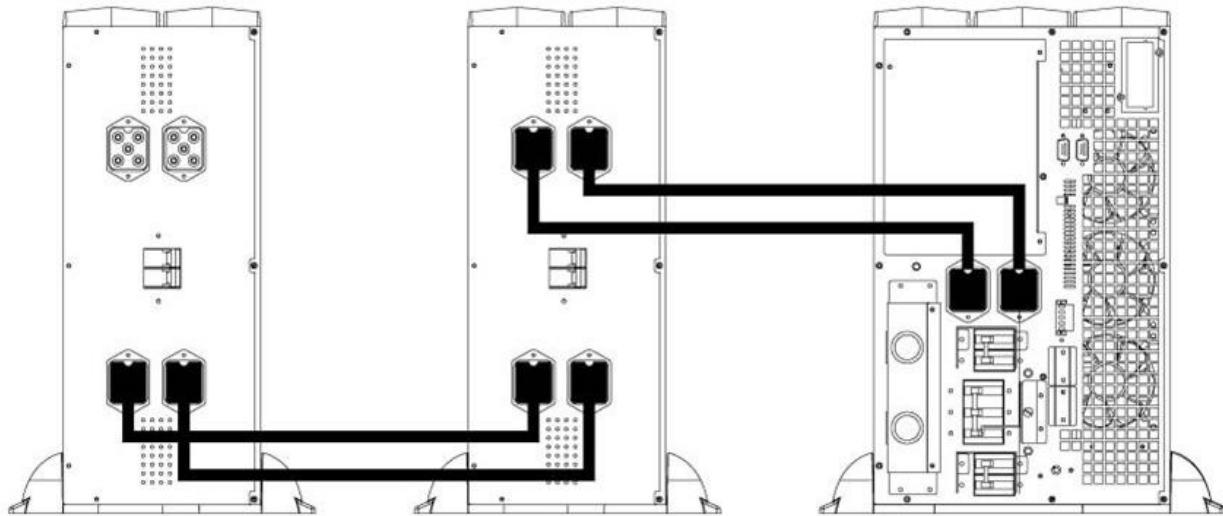

XPRT-10kVA UPS + MULTIPLE BP CABLE INSTALLATION



NOTE

When the UPS is connected to input utility power, and the battery pack is connected to the UPS, the batteries start charging. For best results, allow the UPS to recharge the batteries during a period of approx. 8 hours. It is acceptable to use the UPS without first charging the battery, but the runtime may be reduced.

Connecting Interface Devices

The UPS is equipped with two interface ports: a DB9 communication port and an SNMP card slot. Prepare the serial communication cable (for DB9 communication port connection) or the network cable (for SNMP communication connection) as follows:

1. Choose from the 2 provided ferrite beads the smaller one for serial communication and the bigger one for SNMP communication.
2. Place the cable part that is closest to the UPS connector inside the ferrite bead. For SNMP communication twist it once around the ferrite and place the second winding also inside the ferrite bead.
3. Close the ferrite bead such that the cable remains inside it.

You can now connect the DB9 port to a computer system by connecting the previously prepared serial cable. Additional signals can be read from the serial connector, refer to following table for details.

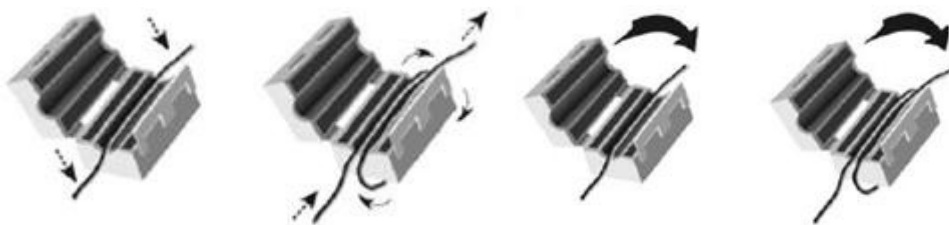

FERRITE BEAD INSTALLATION FOR COMMUNICATION CABLE

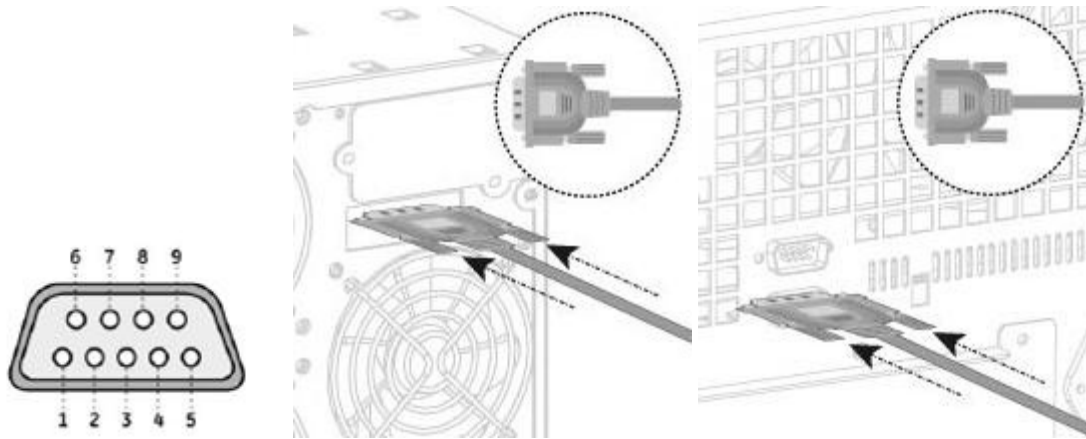

SERIAL CONNECTOR (DB9) PIN OUTS & CABLE INSTALL

1. Battery Low open collector	2. TxD (serial communication)
3. RxD (serial communication)	4. Remote shutdown (only on battery)
5. Communication ground	6.
7. Battery Low open emitter	8. Utility failure open emitter
9. Utility failure open collector	

Open the SNMP slot by removing the two screws and the cover, then pull in the easy installation SNMP Card and connect previously prepared network cable.

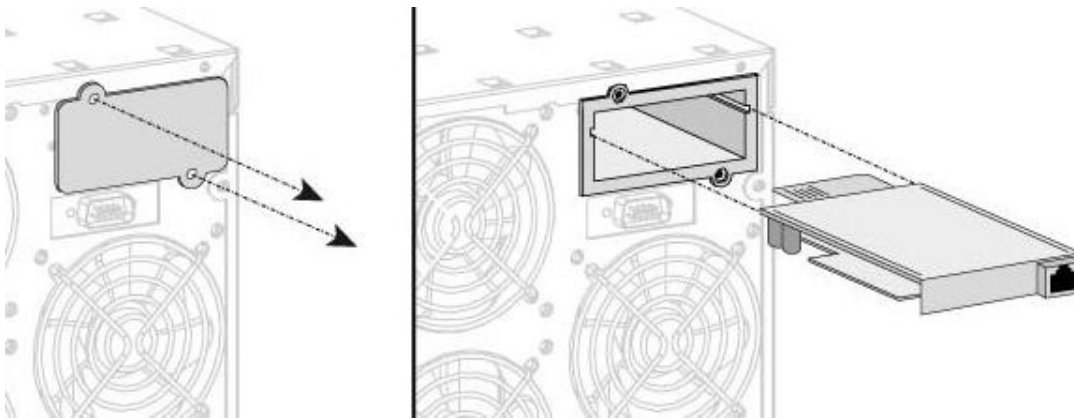

SNMP CARD INSTALL 6KVA UPS

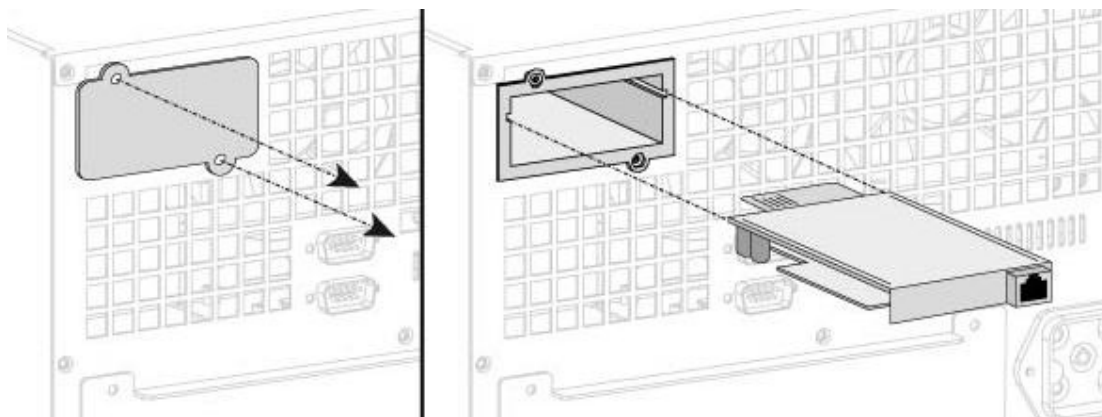

SNMP CARD INSTALL 10KVA UPS

Standard Hardwired Installation Procedure



NOTE

Ensure that the UPS is isolated prior to installation; no live input source may be connected to the UPS during the installation procedure. Open all the input/output switches/breakers on the power distribution and ensure no one is able to close them during this installation step.

1. For installation with Optional Power Distribution Unit please see the appropriate section of this manual.
2. Remove the terminal cover

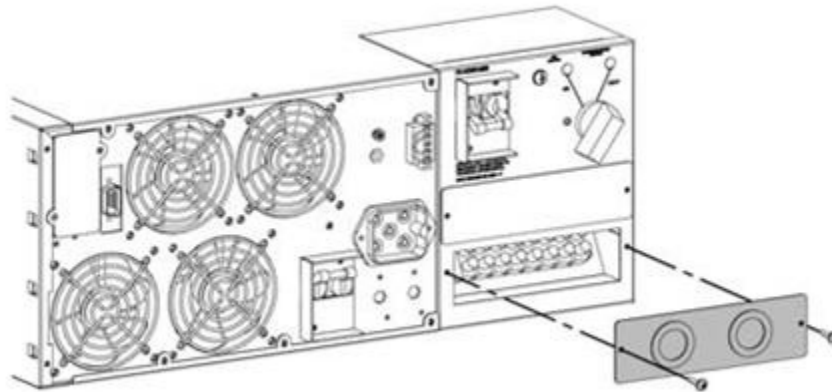

HARDWIRE INSTALL 6KVA UPS

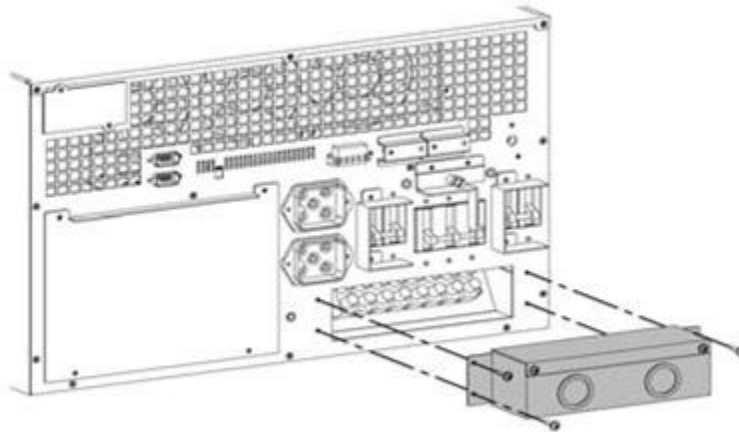

HARDWIRE INSTALL 10KVA UPS

3. Punch out the appropriate holes in the terminal cover. Secure the input/output cables using appropriate hardware

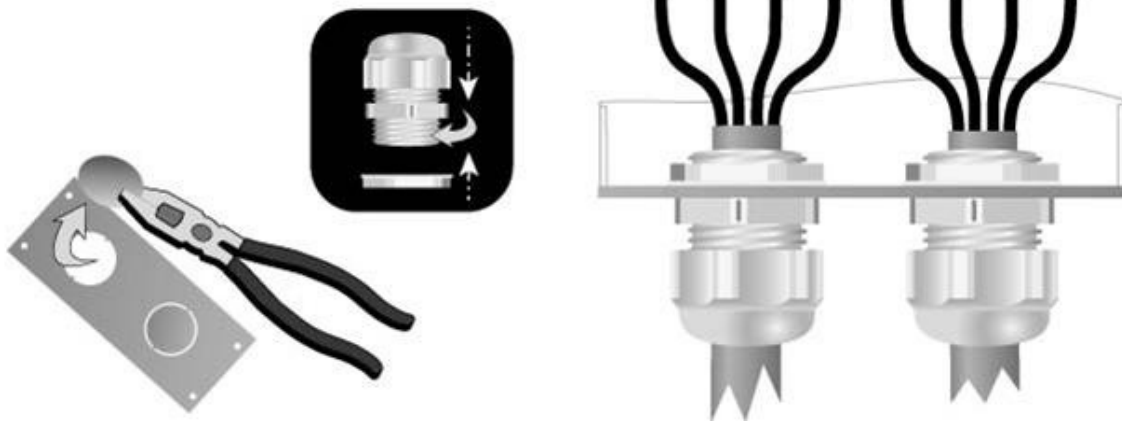

HARDWIRE INSTALL 6/10KVA UPS

- Input:** connect the input utility wires to the terminals L1-L2 (Line) and N (Neutral) and the ground wire to GRD. Ground connection is essential.

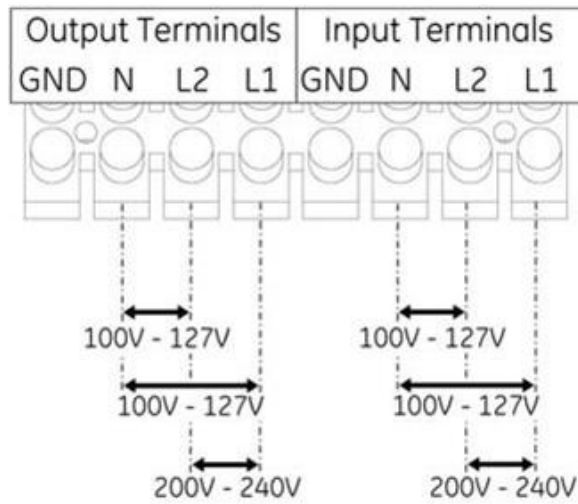

HARDWIRE WIRE CONNECTIONS 6KVA UPS



NOTE

Use No. 10 AWG, 75C Copper Wire.
Terminal tightening Torque: 20 in-lb.

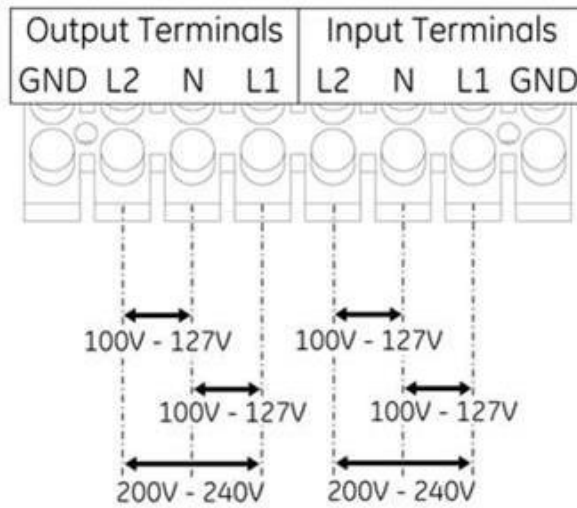

HARDWIRE WIRE CONNECTIONS 10KVA UPS



NOTE

Use No. 6 AWG, 75C Copper Wire.
Terminal tightening Torque: 20 in-lb.

- Output:** connect the load wires to the terminals L1-L2 (Line) and N (Neutral) and the ground wire to GRD. Ground Re-install the terminal cover.

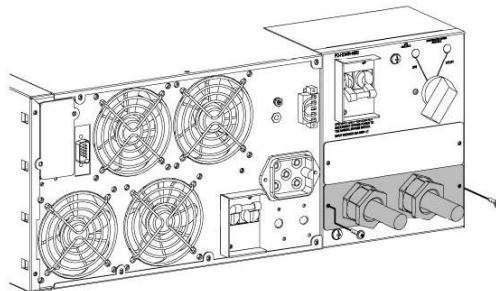

HARDWIRE TERMINAL COVER RE-INSTALL 6KVA UPS

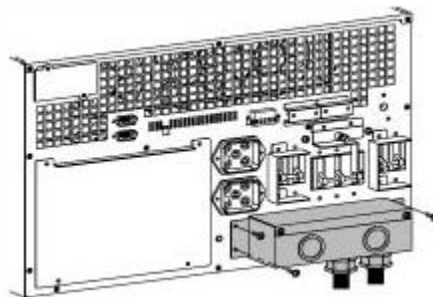

HARDWIRE TERMINAL COVER RE-INSTALL 10KVA UPS

- In case of external batteries, ensure the battery cable is connected between the battery cabinet and the UPS.
- Connect utility power to the UPS.
- Proceed to the Quick Start section of these instructions.

If parallel-operating units will be installed, please reference that section of these instructions.

**NOTE**

The UPS output sockets are live soon as the UPS is connected to the input utility power, even if the UPS has not been switched on via the front panel.

For 6kVA models an additional ground connection is required (the main ground can be removed with the PDU). Connect the UPS case to the nearest available ground connection with an 8 AWG (10 mm²) copper wire.

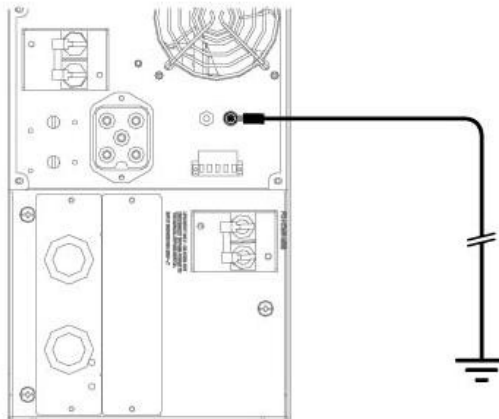

ADDITIONAL GROUND CONNECTION 6KVA UPS

Optional Power Distribution Units

A different power distribution set, equipped with Maintenance Bypass switch, can be installed on the rear side of the unit.

To replace the Power Distribution Unit on the 6kVA or to place the optional Power Distribution Unit on the 10kVA, proceed as follows:

1. Ensure the UPS is completely shutdown, with all breakers opened.
2. Disconnect internal batteries and external battery packs by removing cabling from the UPS DC connector.
3. On the 6kVA model, remove all power connection cables from the installed PDU
4. On the 6kVA model, loosen the three mounting screws on the installed PDU until the PDU can be removed from the UPS cabinet.

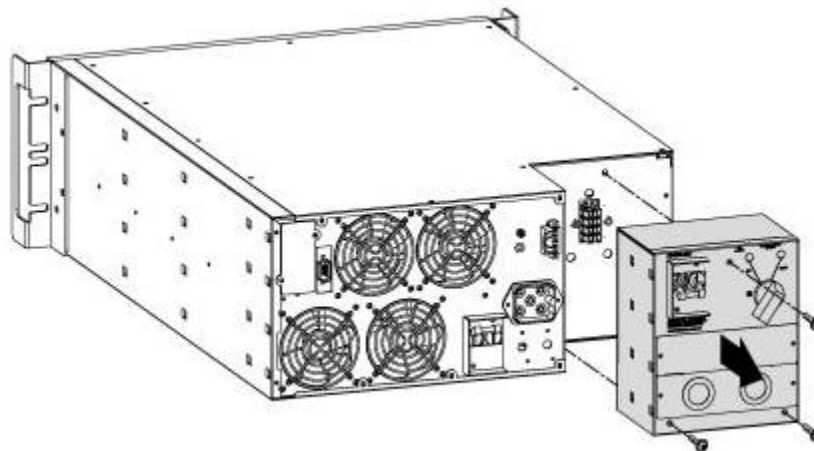

PDU REMOVAL 6KVA UPS

5. On the 10kVA model, loosen the four mounting screws on the PDU cover and remove it.

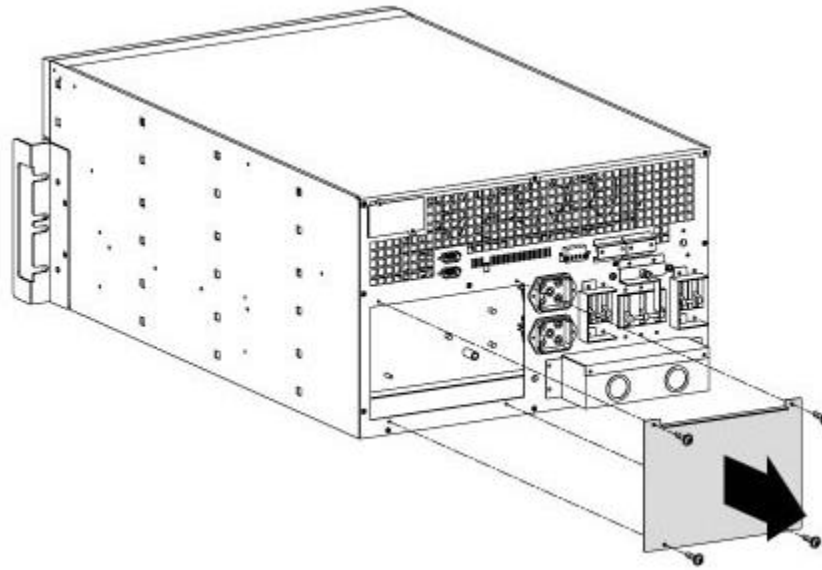
**PDU COVER REMOVAL 10KVA UPS**

6. Remove the PDU from the UPS.

The UPS is now ready for the new PDU assembly.

7. On the 6kVA model, align terminals on the backside of the PDU with the ones on the UPS, and slide the PDU into the UPS.

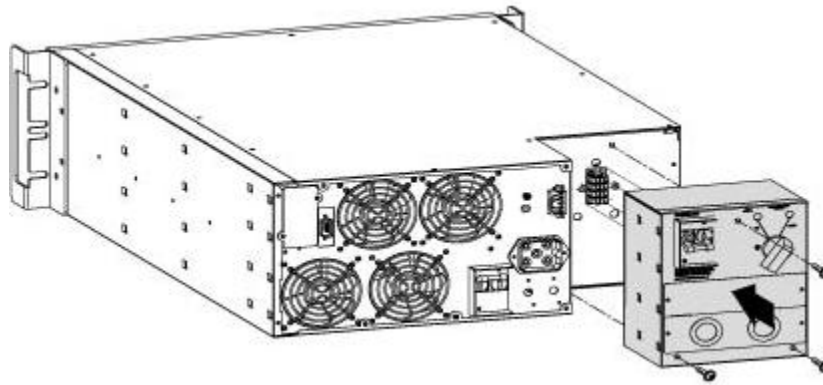
**PDU INSTALL 6KVA UPS**

8. On the 10kVA model, connect terminals on the backside of the PDU with connections in the PDU tray on the backside of the UPS, and slide the PDU into the UPS.

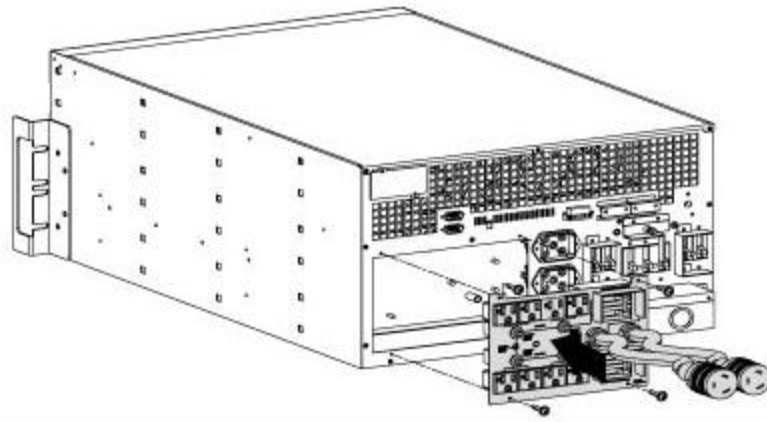

PDU INSTALL 10KVA UPS

Startup

Startup 6kVA UPS

1. Ensure that all breakers on the UPS are off.
2. In case external battery packs are used, switch on the battery pack circuit breaker.

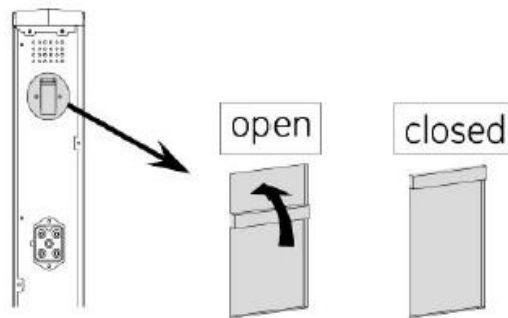

6KVA BATTERY PACK BREAKER

3. Ensure that the manual bypass switch on the PDU is turned to the "UPS" position.

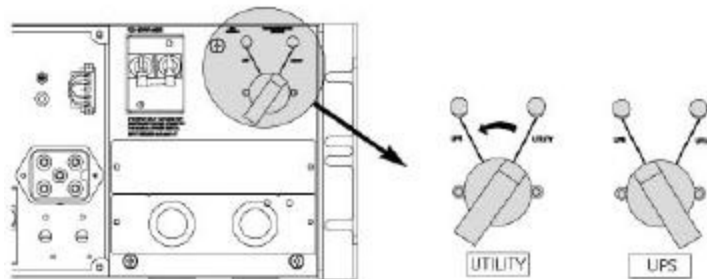

6KVA PDU BYPASS SWITCH

4. Close all switches and breakers upstream from the UPS.
5. Switch the INPUT CIRCUIT BREAKER placed on the rear side of the UPS to "ON" position.

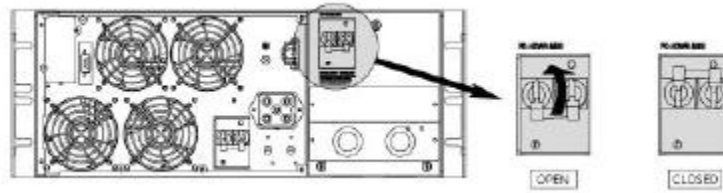

6KVA INPUT CIRCUIT BREAKER

6. Wait 45 seconds to allow the output voltage to stabilize.
7. Press the keypad "UPS ON" for 1 second. Within a few seconds "OPERATION" LED will be illuminated and "BYPASS" LED will be extinguished.
8. Close the OUTPUT CIRCUIT BREKAER on the rear side of the UPS.

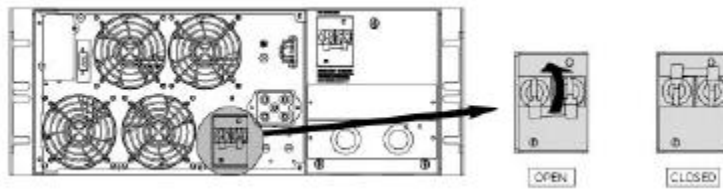

6KVA OUTPUT CIRCUIT BREAKER

9. The UPS is now in operation; equipment connected to the UPS output can now be switched on.
10. Load % will be shown on the "LOAD" LED BAR.

Startup 10kVA UPS (stand-alone not parallel systems)

1. Ensure that all breakers on the UPS are off.
2. In case external battery packs are used, switch on the battery pack circuit breaker.

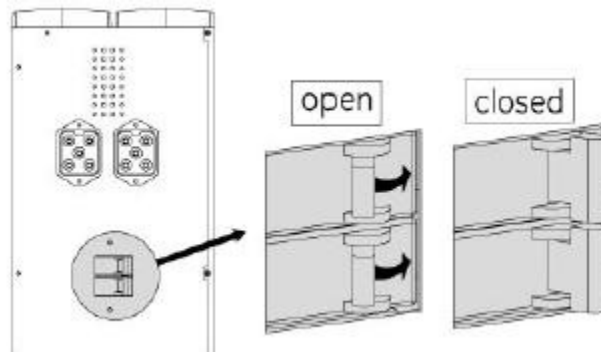

10KVA BATTERY PACK BREAKER

3. Ensure that the bypass circuit breaker on the UPS is turned to the "UPS" position, or that the protection bar is still mounted.

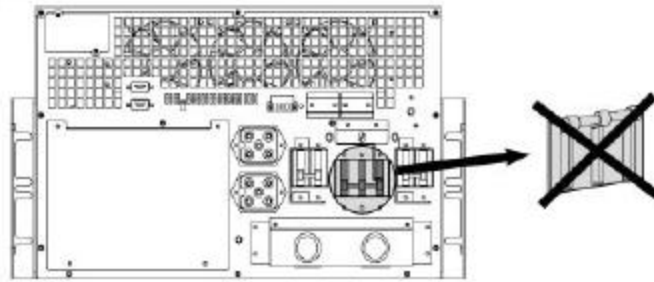
**10KVA BYPASS CIRCUIT BREAKER**

4. Close all switches and breakers upstream from the UPS.
5. Switch the INPUT CIRCUIT BREAKER placed on the rear side of the UPS to "ON" position. The GREEN "UTILITY INPUT" LED will be illuminated.

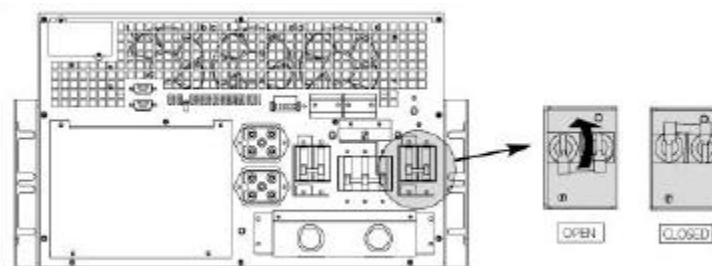
**10KVA INPUT CIRCUIT BREAKER**

6. Wait 45 seconds to allow the output voltage to stabilize.
7. Press the keypad "UPS ON" for 1 second. Within a few seconds "OPERATION" LED will be illuminated and "BYPASS" LED will be extinguished.
8. Close the OUTPUT CIRCUIT BREAKER on the rear side of the UPS.

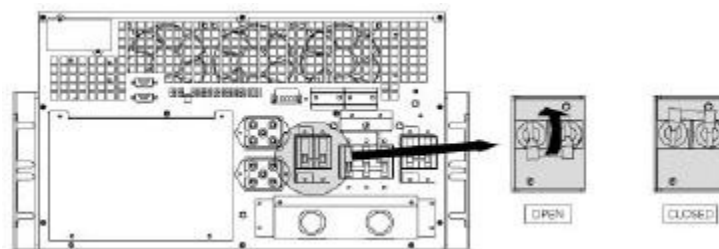
**10KVA OUTPUT CIRCUIT BREAKER**

9. The UPS is now in operation; equipment connected to the UPS output can now be switched on.
10. Load % will be shown on the "LOAD" LED BAR.

Operation

Normal Operation Conditions

1. The UTILITY INPUT is present and within the tolerance as show in Specification section of this manual.
2. The UPS is turned ON.
3. The LOAD does not exceed the capacity of the UPS.
4. The OPERATING TEMPERATURE is below alarm level.

Switching the UPS OFF

1. Make sure that the load has been shut down in an orderly manner.
2. Press the keypad for 1 second to switch the UPS to BYPASS.

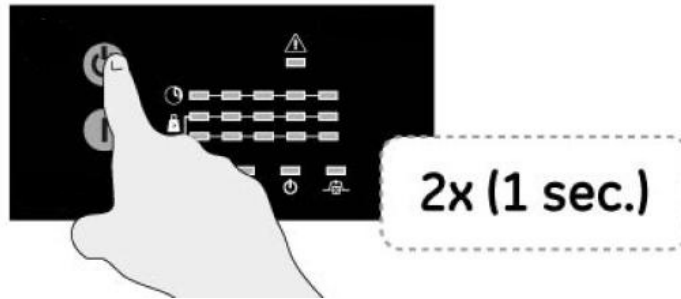

TO TURN THE UPS OFF

3. Press the keypad for a second time for 1 second to switch the UPS OFF.

If electrical isolation is required (e.g. for maintenance purposes) proceed with the following steps

4. Turn the OUPUT CIRCUIT BREAKER to OFF position.

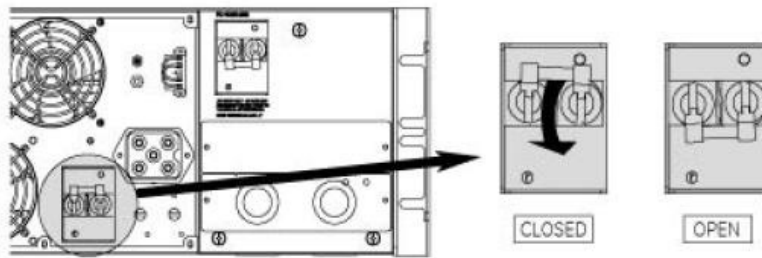

6KVA OUTPUT BREAKER

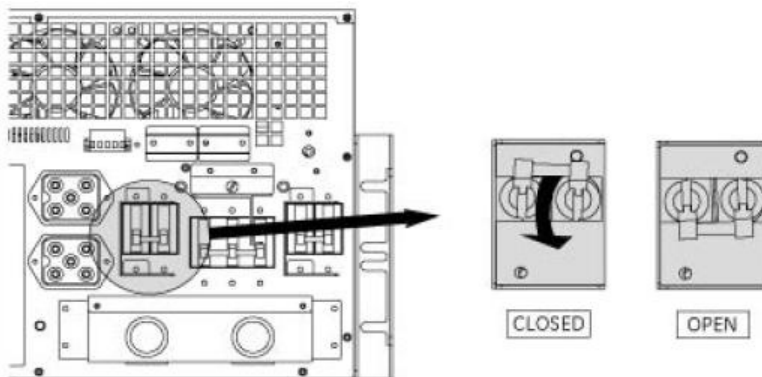

10KVA OUTPUT BREAKER

5. Turn the INPUT CIRCUIT BREAKER to OFF position.

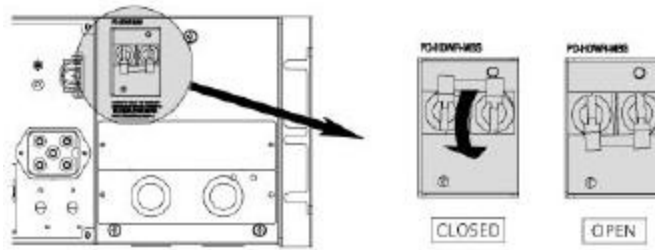

6KVA INPUT BREAKER

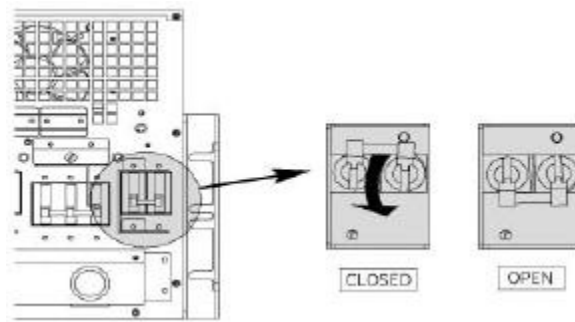

10KVA INPUT BREAKER

6. In case EXTERNAL BATTERY PACKS are connected, switch the BATTERY PACK CIRCUIT BREAKER to the OFF position, and disconnect battery cabling at the rear of the UPS.
7. Open all switches and breakers upstream to the UPS.
8. Remove internal and external battery pack connections and disconnect additional battery packs.

All LEDs should be out on the front panel of the UPS; the UPS is shutdown.

Maintenance Bypass

It is possible to bypass the UPS for maintenance purposes using the Maintenance Bypass Switch on the 6kVA PDU or use the standard bypass built into the 10kVA model. If required, proceed with the following steps:

1. Switch the UPS on BYPASS by
 - a. For 6kVA
 - i. Press the keypad UPS OFF button on the front panel for 1 second.
 - ii. Switch the Maintenance Bypass Switch to BYPASS.

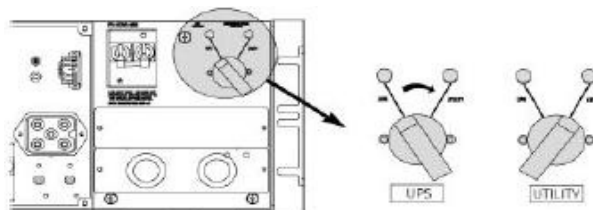

6KVA MAINTENANCE BYPASS SWITCH TO UTILITY

- iii. Switch the UPS off by pressing the keypad UPS OFF button on the front panel for 1 second.
 - iv. Open the OUTPUT CIRCUIT BREAKER.
 - v. Open the INPUT CIRCUIT BREAKER.
 - b. For 10kVA

- i. Remove the BYPASS PROTECTION COVER.

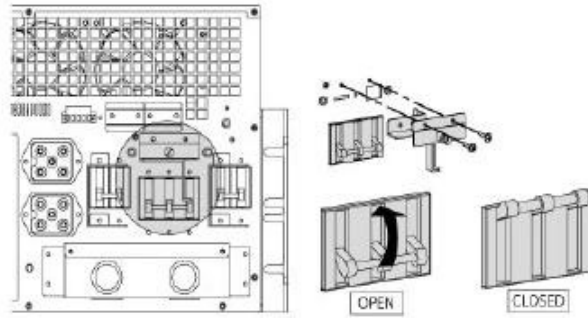

10KVA MAINTENANCE BYPASS SWITCH TO UTILITY

- ii. Remove the BYPASS LOCK PLATE before switching to BYPASS.
- iii. Press the keypad UPS OFF button on the front panel for 1 second.
- iv. Switch the Maintenance Bypass Switch to BYPASS.
- v. Open the OUTPUT CIRCUIT BREAKER.
- vi. Open the INPUT CIRCUIT BREAKER.

- 2. The UPS is now operating in UTILITY BYPASS MODE and maintenance can be performed.



NOTE

After the UPS is shutdown or in “External Bypass” condition, the residual DC voltage in the unit will be eliminated within 5 minutes.

Once the maintenance is performed on the UPS, resume normal conditions by following these steps:

1. Close the INPUT CIRCUIT BREAKER.
2. Wait 45 seconds to allow the output voltage to stabilize.
3. Press the keypad UPS ON for 1 second. Within a few seconds OPERATION LED will be illuminated and BYPASS LED will be extinguished.
4. Switch the UPS to BYPASS by pressing the keypad UPS OFF on the front panel for 1 second.
5. Close the OUTPUT CIRCUIT BREAKER.
6. For the 6kVA switch the Maintenance Bypass Switch to UPS position.

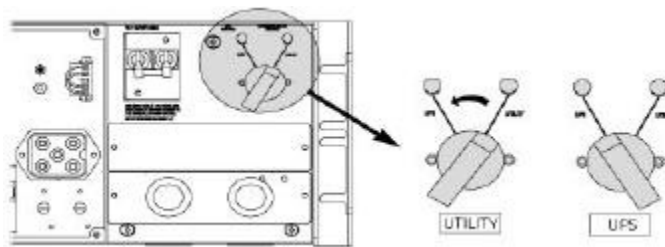

6KVA MAINTENANCE BYPASS SWITCH TO UPS

- 7. For the 10kVA switch the Maintenance Bypass Switch to UPS position and secure the bypass lock plate.

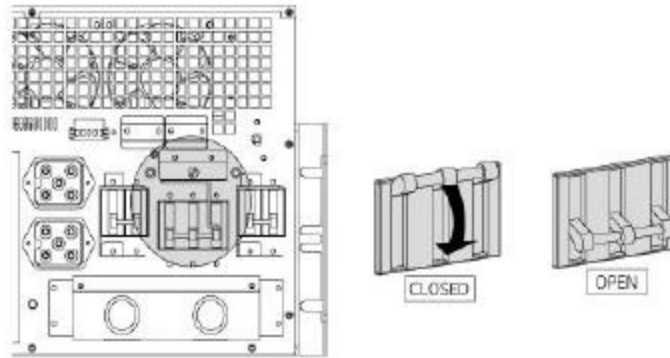

10KVA MAINTENANCE BYPASS SWITCH TO UPS

8. Press the keypad UPS ON for 1 second.

Now the UPS is protecting the load again.

10kVA Parallel Installation And Operation

The paralleling cable delivered with each 10kVA UPS allows you to connect up to (3) 10kVA UPS together in a parallel system.



NOTE

The units connected in parallel must be the same power rating and must have the same output voltage setting (i.e. 120V-120V not 120V-127V).

The paralleling cable delivered with each 10kVA UPS allows you to connect up to (3) 10kVA UPS together in a parallel system.

Installation of a Parallel System

1. All inputs of the UPS must be supplied from the same source. Be sure that L1 / L2 / N correspond on all the units of the parallel system. All inputs must be individually protected with fuses or breakers.
2. All outputs must be connected together, supplying the load. It is advised to install breakers (S 1,2,3) in the output wiring, in order to be able to isolate a unit from the remaining system for service and maintenance purposes. Optional Xtreme Power paralleling / bypass panels are available to accomplish this (not shown). Please contact Xtreme Power Sales for additional information.

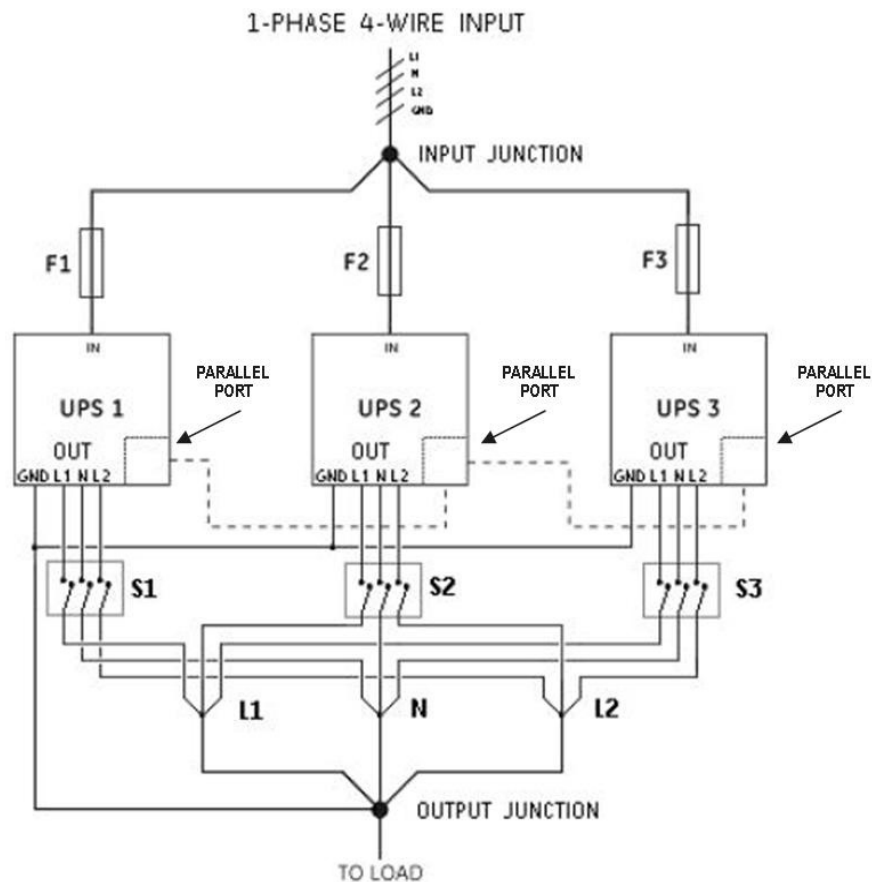

10KVA UPS PARALLEL SYSTEM DIAGRAM EXAMPLE

3. Use insulated copper input and output wiring, rated 90°C (194°F) wire size based on the ampacities given in Tables 310-16 of the National Electrical code, ANSI/NFPA 70-1993.
4. The length of all input cables from the input junction to the UPS inputs should be equal. The same applies to the cables from the outputs to the output junction. The minimum length of the input as well as the output cables is 3 meters.
5. The overall system load may not exceed 100% load of a single UPS in the configuration without the addition of an external maintenance bypass. Optional Xtreme Power bypass panel is available to meet this requirement. Please contact Xtreme Power Sales for additional information.

Installing the Parallel Connection



NOTE

Ensure that the UPS is isolated prior to installation; no live input source may be connected to the UPS during the installation procedure. Open all the input/output switches/breakers on the power distribution and ensure no one is able to close them during this installation step.

1. Locate the parallel port on the rear side of the UPS and remove the parallel communications cover

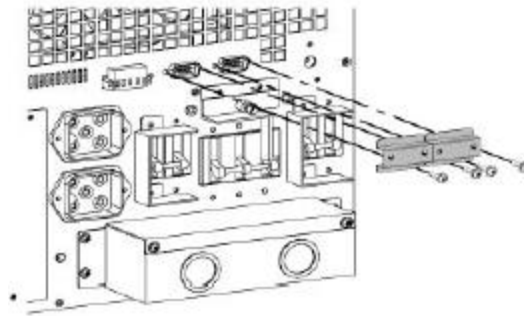

10KVA UPS REMOVE PARALLEL PORT COVER

- 2. Connect the DB9 parallel cable provided with the UPS to the parallel port.

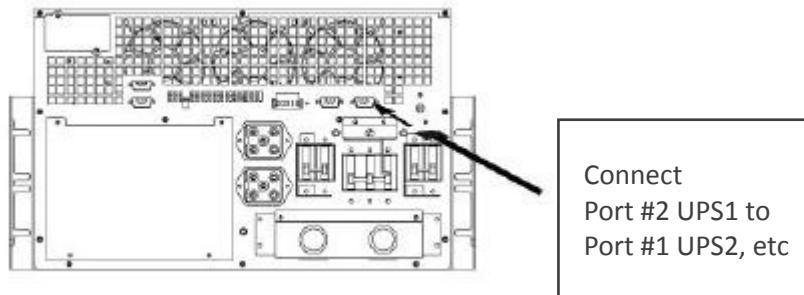

10KVA UPS CONNECT DB9 PARALLEL CABLE

- 3. One cable connects two UPS is parallel. To connect a third UPS into the parallel system, repeat the process as above.

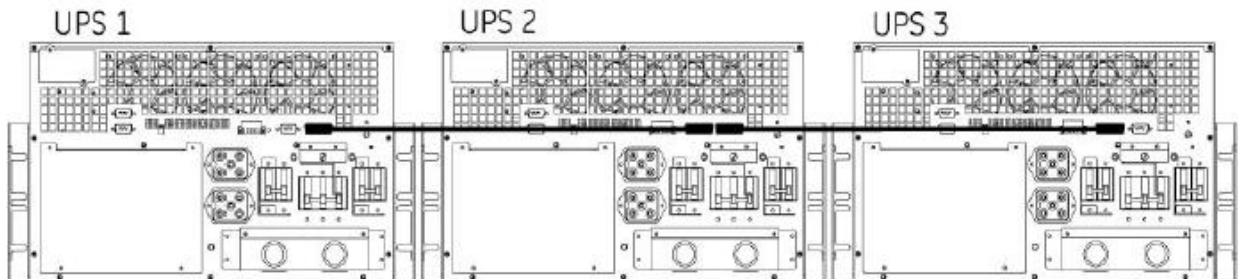

10KVA UPS CONNECTING 3 PARALLEL UNITS

- 4. For a quick start of the system, proceed to the Startup section of this manual.
- 5. Each UPS needs a different configuration of the DIP switch as identification of unit in the parallel system.

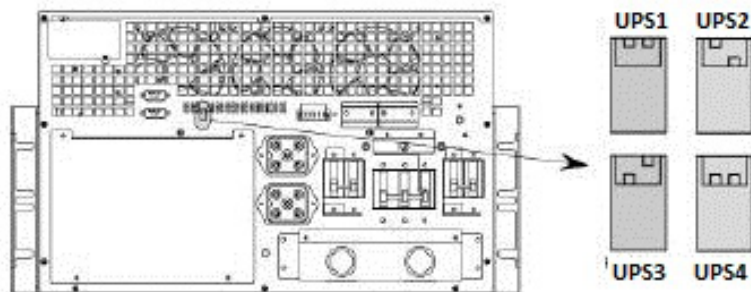

PARALLEL DIP SWITCH

Startup 10kVA UPS Parallel System

1. Ensure that all breakers on the UPS are off.
2. In case external battery packs are used, switch on the battery pack circuit breaker.
3. Ensure that the bypass circuit breaker on the UPS is turned to the "UPS" position, or that the protection bar is still mounted.
4. Close all switches and breakers upstream from the UPS.
5. Switch the INPUT CIRCUIT BREAKER placed on the rear side of the UPS to "ON" position in sequence. The GREEN "UTILITY INPUT" LED will be illuminated.
6. Wait 45 seconds to allow the output voltage to stabilize.
7. Press the keypad "UPS ON" for 1 second. Within a few seconds "OPERATION" LED will be illuminated and "BYPASS" LED will be extinguished.

REPEAT STEPS FOR ADDITIONAL 10KVA UPS IN PARALLEL CONFIGURATION

8. Close the OUTPUT CIRCUIT BREAKER on the rear side of the UPS.
REPEAT STEP FOR ADDITIONAL 10KVA UPS IN PARALLEL CONFIGURATION
9. The UPS is now in operation; equipment connected to the UPS output can now be switched on.
10. Load % will be shown on the "LOAD" LED BAR.

Normal Operation Conditions

1. The UTILITY INPUT is present and within the tolerance as show in Specification section of this manual.
2. The UPS is turned ON.
3. The LOAD does not exceed the capacity of the UPS.
4. The OPERATING TEMPERATURE is below alarm level.

Switching the UPS OFF

1. Make sure that the load has been shut down in an orderly manner.
2. Turn the OUTPUT CIRCUIT BREAKER to OFF position.
3. Press the keypad  for 1 second to switch the UPS to BYPASS.

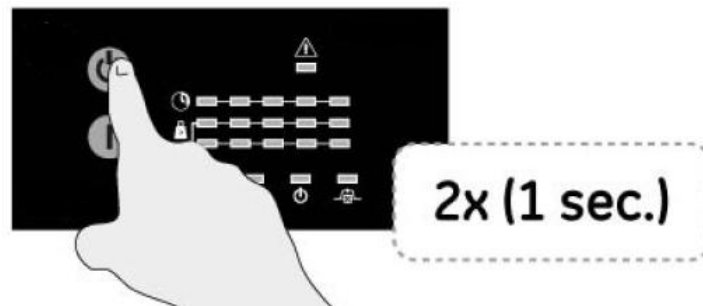

TO TURN THE UPS OFF

Press the keypad  for a second time for 1 second to switch the UPS OFF.

4. Turn the INPUT CIRCUIT BREAKER to OFF position.

If electrical isolation is required (e.g. for maintenance purposes) proceed with the following steps

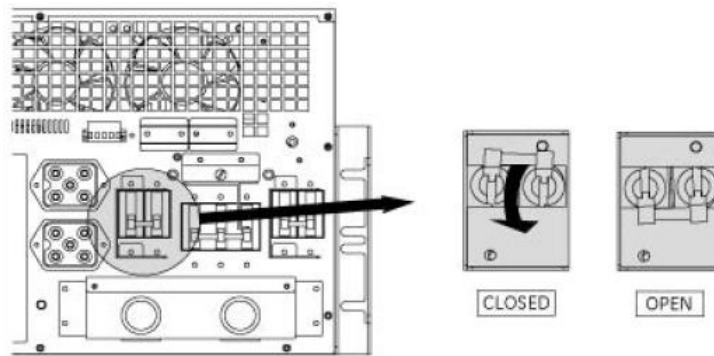
**10KVA OUTPUT BREAKER**

5. Turn the INPUT CIRCUIT BREAKER to OFF position.

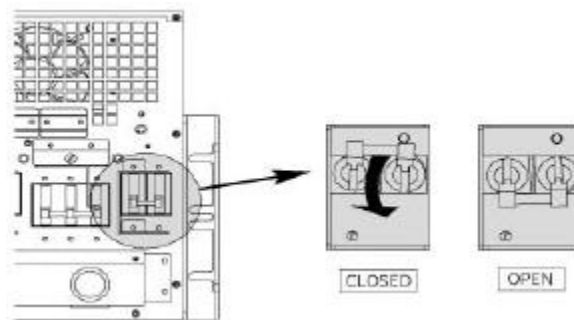







**10KVA INPUT BREAKER**

6. In case EXTERNAL BATTERY PACKS are connected, switch the BATTERY PACK CIRCUIT BREAKER to the OFF position, and disconnect battery cabling at the rear of the UPS.
7. Open all switches and breakers upstream to the UPS.
8. Remove internal and external battery pack connections and disconnect additional battery packs.

All LEDs should be out on the front panel of the UPS; the UPS is shutdown.

REPEAT STEP FOR ADDITIONAL 10KVA UPS IN PARALLEL CONFIGURATION

Status and Alarm Indications

SITUATION		INDICATORS ON FRONT PANEL							
									
O	STANDBY			—			1-5 —		
O	NORMAL OPERATION	—		—			1-5 —	0-4 —	
L	OVERLOAD WARNING	—		—			1-5 —		— — — 1/0.5 SEC
H	BATTERY NOT CONNECTED	—		—	— — —	—		0-4 —	
H	REPLACE BATTERY	—		—		—		0-4 —	— — — 1/60 SEC
L	BYPASS OUT OF LIMITS	—	— — —	—			1-5 —	0-4 —	
O	ON BYPASS		—	—			1-5 —	0-4 —	— — — 1/120 SEC
O	ON BATTERY	—			—		1-5 —	0-4 —	
H	BATTERY LOW	—			—		1 — — —	0-4 —	— — — 1/5 SEC
H	FAULT ON BYPASS		—	—		—	— — —	0-5 —	— — —
H	FAULT ON STANDBY					—	— — —		—

- LEGEND**
- O = OPERATION MODE
 - L = LOW PRIORITY ALARMS
 - H = HIGH PRIORITY ALARMS
 - — — = INTERMITTENT
 - = CONTINUOUS
 - 0-5 = NUMBER OF LEDs THAT CAN BE ON DEPENDING ON RUNTIME CAPACITY / LOAD BAR
 - MUTE BUZZER = PRESS BUTTON “|” BRIEFLY

On Bypass

The UPS is equipped with an automatic bypass switch. This switch automatically transfers the load to the utility input power if the UPS is unable to deliver the demanded output power due to overload or over temperature. If all 5 LOAD LEDs are illuminated, bypass operation is caused by an overload. If only first runtime LED is illuminated, bypass operation is caused by over temperature.

The UPS will switch back to normal operation when the overload has been removed. When temperature drops below alarm level unit can be switched back to normal operation. If a power failure occurs during bypass operation, the UPS will switch to battery if possible, otherwise output power is lost.

On Battery

During normal operating conditions, if an input utility failure occurs, the UPS uses the energy stored in the batteries to supply the load. The runtime capacity LED bar will show the remaining time. The UPS will shutdown:

- After the batteries have been discharged (automatic restart if enabled), or
- If keypad 'UPS OFF' is pressed (restart via front panel required), or
- If a 'UPS shutdown' command is given by the computer (via UPS monitoring software). Restart depends on the setting of "auto-restart" function.

Battery Low (end of runtime)

If during battery operation, the buzzer starts beeping every 5 seconds and the first LED of the battery charge bar starts blinking, the batteries are nearly discharged: the remaining runtime is less than 2 minutes (default setting, adjustable via the UPS monitoring software). Controlled shutdown of any computer equipment is absolutely necessary when this alarm is raised.

If the UPS operates at 100% load, the shutdown procedure should be completed within 2 minutes after the 'battery low' alarm started. If only part of the output capacity of the UPS is used this period can be longer, with aged batteries this period can be shorter.

When the batteries are fully discharged, the UPS is no longer able to supply the connected equipment and eventually **output power is lost**.

Bypass Out of Limits

The input utility voltage or input utility frequency is outside bypass tolerance but inside UPS input tolerance. Bypass operation is inhibited: if for whatever reason the UPS is not able to deliver the required output, output power is lost. If the input frequency is often out of tolerance – during which bypass operation is inhibited and an alarm is generated – it may be useful to disable bypass function (via UPS monitoring software) after which the unit operates as a UPS without automatic bypass switch.



NOTE

The unit can be used as frequency converter: the input frequency range is 47.5-63Hz, the output frequency is selectable 50/60 Hz, via UPS monitoring software. If the unit is used in this configuration, the bypass function is no longer available.

Overload

The demanded power exceeds the nominal capacity of the UPS. The "overload warning" alarm occurs when the load exceeds 150% the UPS will immediately switch to bypass, assuming that the conditions for a transfer to bypass are fulfilled.

If an overload condition between 110-150% persists, the UPS will also switch to bypass operation. In both conditions the "overload" alarm is generated.

During an overload the UPS may automatically switch off within a few minutes (load dependent) and output power is lost:

- if a transfer to bypass is inhibited, or
- if the bypass function has been disabled, or
- if the UPS operates on battery.

To avoid these problems, be absolutely certain that the power demand of the protected equipment is within the limits of the UPS.

Replace Battery

Either the batteries are almost chemically worn out or the battery wiring, including the battery fuse, is faulty. If the batteries are aged, they must be replaced as soon as possible to ensure full protection for your equipment. Perhaps the 'replace battery' alarm occurs after a test which you started immediately after installation or after a power failure. In this case the alarm may be incorrect as the batteries have been (partially) discharged during transport or storage or during the power failure. For this reason we advise to execute battery test only after 5 hours on line operation with no input utility failures. This allows the UPS to recharge the batteries.







Alarm Priority

'General alarm' comprises a group of alarms; the buzzer behavior indicates the priority of the generated alarm.

ON:	Battery not connected
1 / 0.5 secs.:	Overload
1 / 4 secs.:	General Alarm
1 / 60 secs.:	Battery test failed
1 / 120 secs.:	On bypass

Fault Mode

The UPS may be in FAULT MODE if the following failure occurred:

FAULT SITUATION		INDICATORS ON FRONT PANEL						
								
H	CHARGER OVER-VOLTAGE	—				—	—	--- 1/4 SEC
H	OUTPUT SHORT CIRCUIT	—					—	--- 1/4 SEC
H	NEGATIVE POWER	—		—			—	
H	OVERLOAD	—	—	—	—	—	—	--- 1/0.5 SEC
H	OVER-TEMPERATURE	—	—					--- 1/4 SEC
H	BEZEL INTERLOCK	—	—		—		—	--- 1/4 SEC

LEGEND

H = HIGH PRIORITY ALARMS

--- = INTERMITTENT

— = CONTINUOUS

In FAULT MODE, the UPS is “forced” on bypass or standby. After having solved the cause of the fault condition, you have to press the UPS OFF button for 0.5 seconds to switch the UPS to normal mode or restart the unit.

Standby

In standby mode, the UPS is turned off (output power is lost) and the batteries are being recharged. To put the UPS in Standby, press for 1 second the UPS OFF switch, the UPS switches to bypass. Press one more time UPS OFF switch for 1 second. The UPS is now in standby mode. Most changes to the UPS settings are only possible in bypass or standby mode.

Remote Emergency Power Off (REPO)

REPO may be created using either normally open or normally closed switch. The unit is shipped with a jumper connected between pin 3-4. In case of connection with a normally open contact, this jumper must be removed and a normally open switch cabling must be connected between pin 1-2. In case of connection with a normally closed contact, the jumper must be shifted between pin 1-2 and the normally close switch must be connected between pin 3-4.

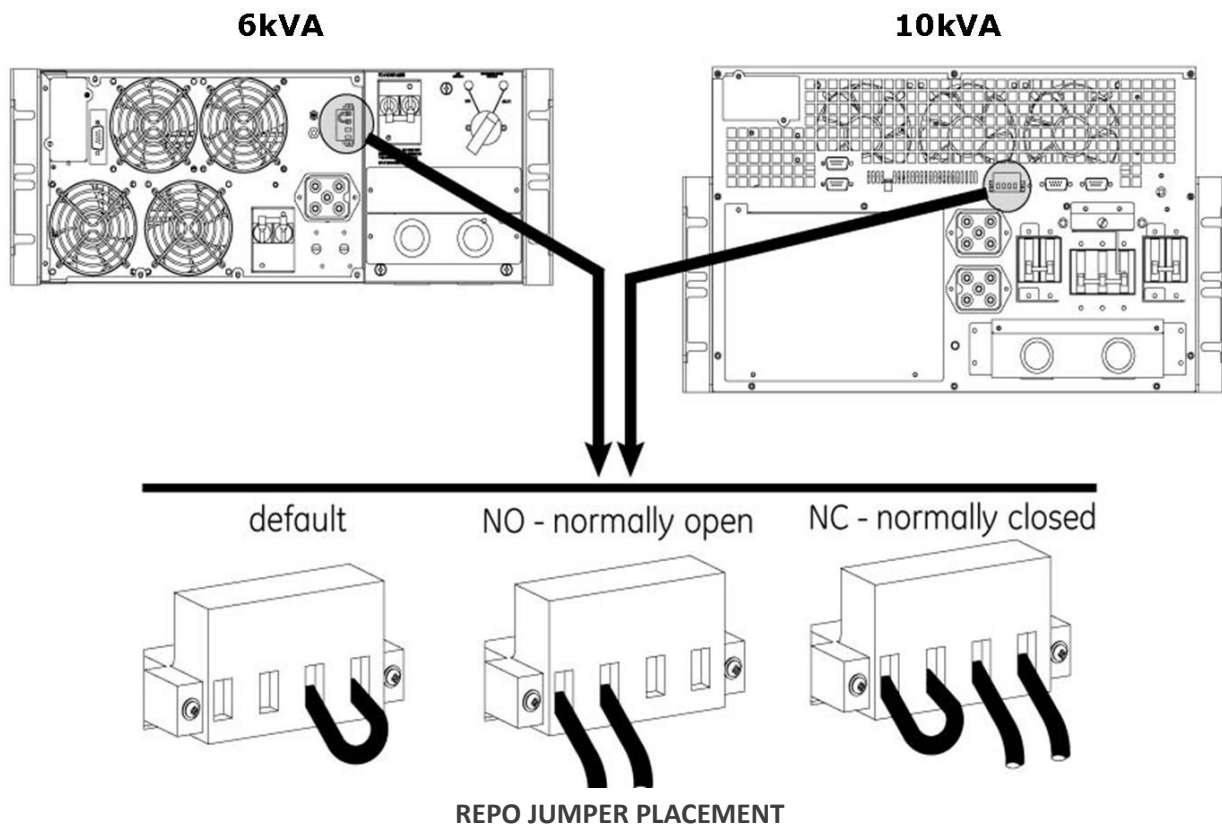

When REPO is activated the UPS will transfer to stand-by mode and output power is lost. It's not possible to restart the unit while the REPO is activated, thus, depending on the used switch, the connection must be restored by closing or opening the contact. Press UPS OFF button 2 times within 4 seconds to be able to restart the unit.

No Load Shutdown

If no load shutdown is enabled, if the load is less than 5% and in case of utility failure, the UPS will switch off, avoiding a deep discharge of the batteries and output power is lost. NO LOAD SHUTDOWN is disabled as default. It is possible to enable this feature via the UPS Monitoring Software.

Auto Restart

Default enabled AUTO RESTART may be disabled via the UPS Monitoring Software. Auto Restart acts after the UPS has been shut down during an input utility failure.

- If the function is set ENABLED, the UPS will automatically restart when the input utility power returns.
- If the function is set DISABLED, a manual restart either via the front panel or the UPS Monitoring Software is required.

Battery Management

Maximum battery life and reliability are obtained by the following features:

Battery Connection Test

At startup, the UPS performs an automatic test to check that the battery cabling and fuses are properly connected. If the test detects a battery disconnection, the corresponding alarm will be generated.

Quick Battery Test

A quick battery test may be launched to check if the batteries are healthy. To start the test, press the UPS ON button for 0.5 seconds when the UPS is in Normal Operation. In case of failure, the corresponding alarm condition will be generated.

Deep Battery Test

A deep battery test will update the runtime calculation, and may be started via the UPS Monitoring Software. The test will start only if the battery charge level is higher than 90%, and the load is at least 20% of the nominal rating. The runtime calculation will be updated only if the test can run uninterrupted for a complete battery discharge.

**NOTE**

When executing a deep battery test, the available runtime in case of input utility failure may be shorter than normal. Don't execute this test if reduced battery runtime is not acceptable.

**NOTE**

It is possible to reset the battery test, by pressing the UPS OFF switch for 0.5 sec. The UPS will switch to bypass mode.

Communication

RS-232 Communication Port

The RS232 port is a plug-in interface port, which enables advanced communication between the UPS and a computer via a serial cable and UPS Monitoring Software. The interface port is already operational in standby mode.

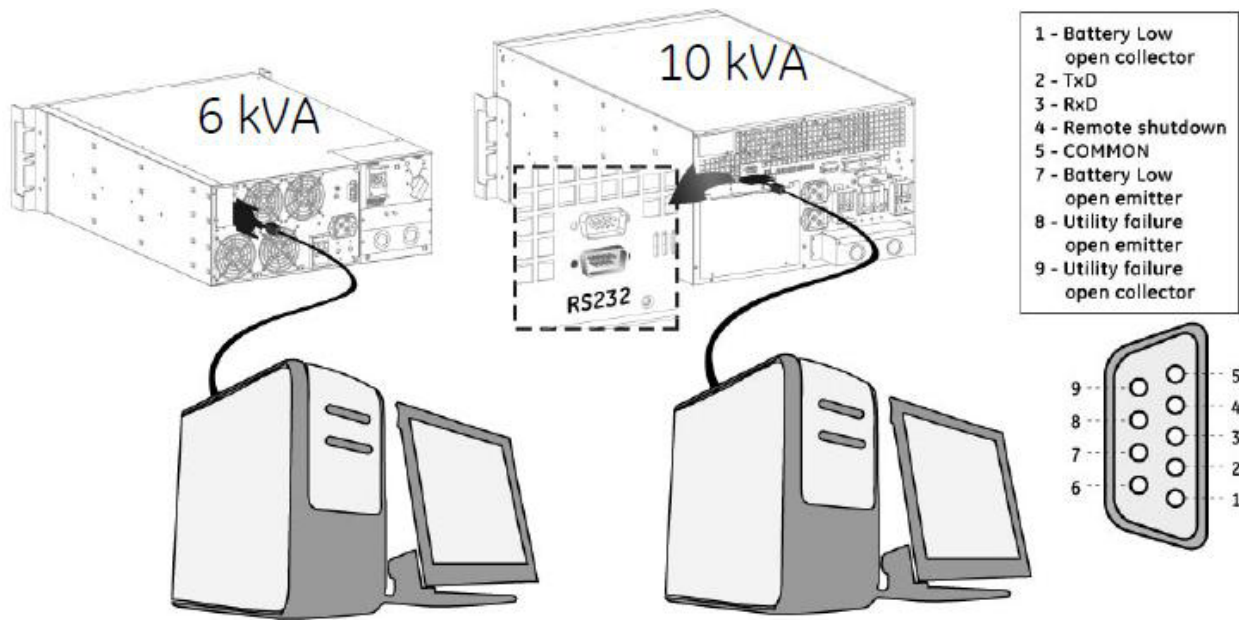

RS232 COMMUNICATIONS

To change settings of the UPS, we strongly recommend to be sure that the UPS is in standby mode. Some settings can only be changed if the UPS operates in bypass or standby mode.



NOTE

The change of some settings can cause the unit to switch from bypass to standby and output power is lost.

For more information regarding possible settings, please refer to the HELP manual on the UPS Monitoring Software CD.

SNMP Interface Card (Option)

This card allows the data interface to be connected directly to an Ethernet network. The card is fitted into the SNMP Card Slot. For more information, please refer to the user manual that comes with the interface card.

Extended Runtime

Extended runtime can be obtained by connecting a separate extended battery pack to the UPS. In this case the UPS must be informed about the new total battery capacity to allow a reliable recalculation of the available runtime (via UPS Monitoring Software). Depending of the charge condition of the new batteries the new runtime calculations may temporarily be unreliable.

Additional batteries increase the recharging time for the unit; all other operational information is the same as for standard models. The following table shows runtimes with up to 3 Battery Packs. 1 Battery Pack is the normal configuration.

UNIT	LOAD	ESTIMATED RUNTIME IN MINUTES				
		INTERNAL BATTERIES	1 BATTERY PACK	2 BATTERY PACKS	3 BATTERY PACKS	4 BATTERY PACKS
XPRT-6000	10%	75	156	235	313	391
	25%	31	75	115	155	195
	50%	14	34	58	82	105
	75%	8	22	35	50	65
	100%	5	14	25	36	47
XPRT-10000	10%	107	251	333	494	590
	25%	40	100	160	225	290
	50%	16	39	66	92	119
	75%	10	24	41	58	75
	100%	6	17	28	41	54

Maintenance

Safety



DANGER

When the UPS operates, all parts of the electronics are directly connected to the utility and high voltages are present on all internal parts, including the battery. Even after disconnection from the utility, all parts inside the UPS, including the battery, conduct dangerous voltages (except the COM port output). For your safety, only authorized service personnel may remove the UPS or BP cabinet cover.

General

The XPRT Series UPS is virtually maintenance free. Adhere to proper environmental requirements as shown in the Specification, and keep the air inlets / outlets free of dust.



NOTE

Except for battery replacement, refer maintenance and service work to qualified and skilled personnel only.

Recycling the UPS at the End of Service Life



NOTE

This product has been designed with respect to the environment, using materials and components respecting eco-design rules. It does not contain CFCs (Carbon Fluorine Chloride) or HCFCs (Halogen Carbon Fluorine Chloride).



The batteries contain lead, which is a harmful substance for the environment. Proper disposal or recycling of the batteries is required. Refer to your local codes for disposal requirements.



Xtreme Power Conversion Corp, in compliance with environment protection recommends that the UPS equipment, at the end of its service life, must be recycled conforming to the local applicable regulations.

Batteries

The service life of the batteries in this UPS and BP is from 3 to 5 years, depending on the operating temperature and number of discharge cycles.

A healthy battery is critical to the performance of the UPS. An automatic quick battery test is performed regularly to ensure failsafe operation. When the condition of the battery is critical, a REPLACE BATTERY alarm will be activated. Replace the batteries as soon as possible.

General Guidelines:

- When replace the batteries, use all the same type and size.
- Never short the battery terminals. Shorting may cause the battery to burn. When working with batteries, remove watches, rings or other metal objects, and only use insulated tools.
- Avoid charging batteries in a sealed container.
- Proper disposal of batteries is required. Refer to your local codes for disposal requirements.
- Never dispose of batteries in fire - they may explode.
- Never dismantle or reassemble batteries - their contents (electrolyte) may be extremely toxic. If exposed to electrolyte, wash immediately with plenty of water. If eye contact occurs, flush with water and contact a physician.

Internal Battery Replacement – 6kVA Model

In case of battery failure, please proceed with the following steps.



NOTE

During battery replacement the UPS will not be able to support the load if an input utility failure occurs! It is recommended to switch off the load before battery replacement.

1. Remove the UPS front cover from the UPS cabinet by gently pulling it out.
2. Remove the battery grille by loosening the two mounting screws.

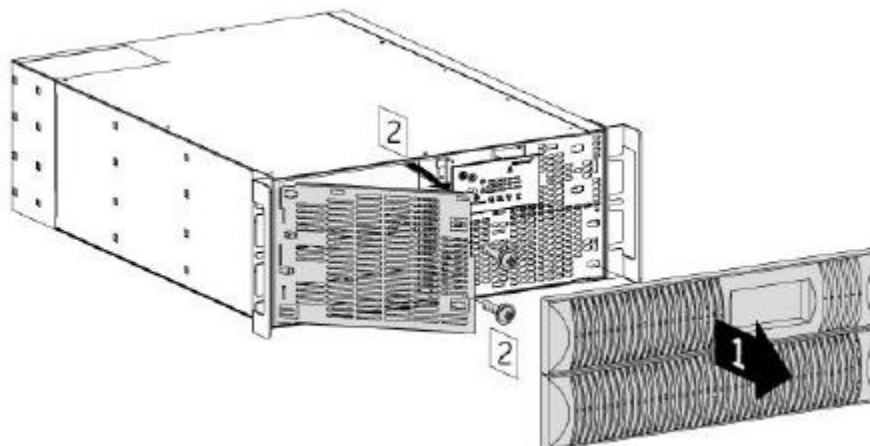

FRONT COVER REMOVAL

- Grab hold of the battery tray and slide it out. Be careful during this operation and consider the weight of the battery.

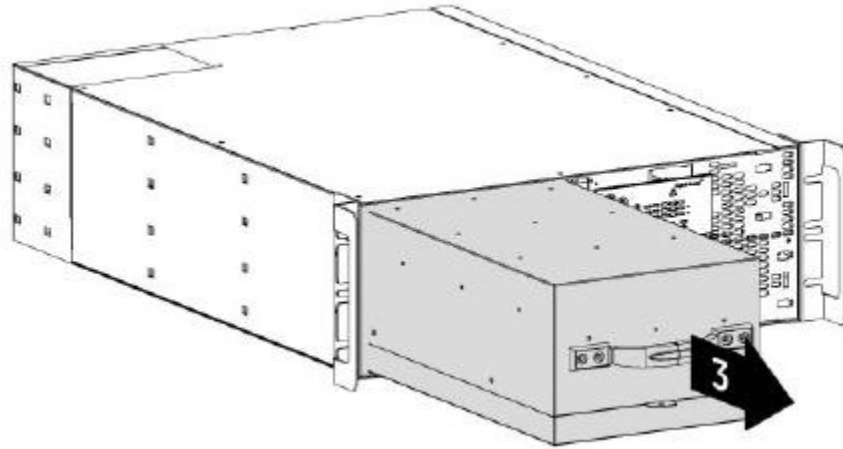

BATTERY TRAY REMOVAL

- Unpack the new battery tray from its box.
- Place the battery tray in front of the battery compartment, aligning the rear connector to the front panel.
- Slide the battery tray into the battery compartment until the rear connector is plugged with the UPS internal DC socket.
- Fix the battery grille by tightening screws.
- Re-install the two front covers.



NOTE

To avoid battery malfunction, in case of additional batteries connected, all battery packs have to be replaced! It's not possible to replace only 1 pack. Avoid connection between new and old battery packs.

Internal Battery Replacement – 10kVA Model

In case of battery failure, please proceed with the following steps.



NOTE

During battery replacement the UPS will not be able to support the load if an input utility failure occurs! It is recommended to switch off the load before battery replacement.

- Remove the UPS front cover from the UPS cabinet by gently pulling it out.
- Remove the battery grille by loosening the three mounting screws.

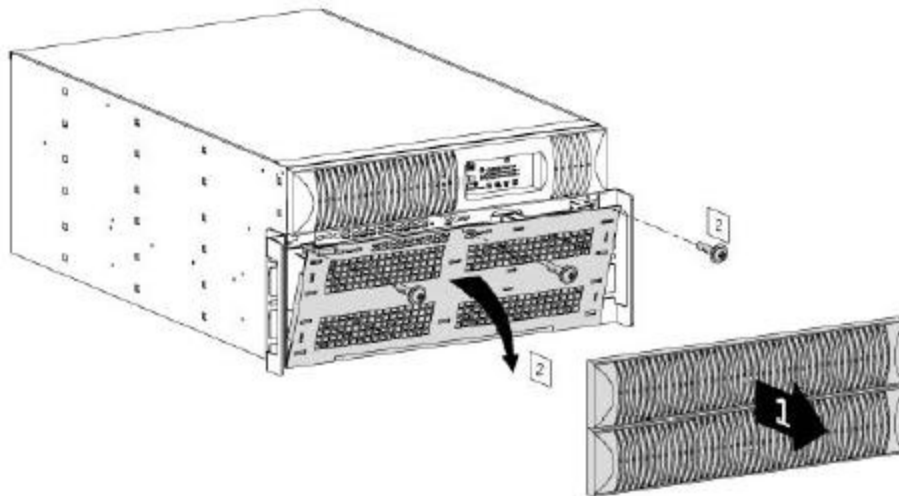

FRONT COVER REMOVAL

3. Disconnect DC cabling from battery tray connectors.
4. Grab hold of the battery trays and slide it out. Be careful during this operation and consider the weight of the battery.

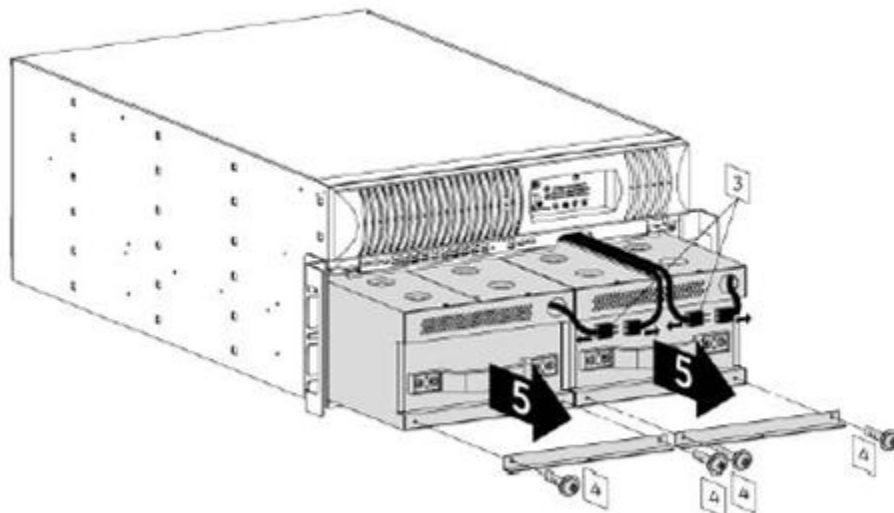

BATTERY TRAY REMOVAL

5. Unpack the 2 new battery trays from their boxes.
6. Place the battery trays side by side in front of the battery compartment, aligning the rear connector to the front panel.
7. Slide the battery tray into the battery compartment and reconnect the DC cabling on each battery tray. Affix the 2 battery brackets with the screws to hold the battery trays in the UPS cabinet.
8. Fix the battery grille by tightening screws.
9. Re-install the two front covers.



NOTE

To avoid battery malfunction, in case of additional batteries connected, all battery packs have to be replaced! It's not possible to replace only 1 pack. Avoid connection between new and old battery packs.

Power Unit Maintenance

For maintenance purposes, the power unit can be replaced while output is transferred to manual bypass. See the following detailed steps for the replacement procedure.



WARNING

The UPS has to be switched to manual bypass before power unit replacement, otherwise **output power is lost**.

Power Unit Replacement – 6kVA Model

1. Switch the UPS to manual bypass.
2. Loosen the 3 mounting screws on the PDU and slide it out from the power module.

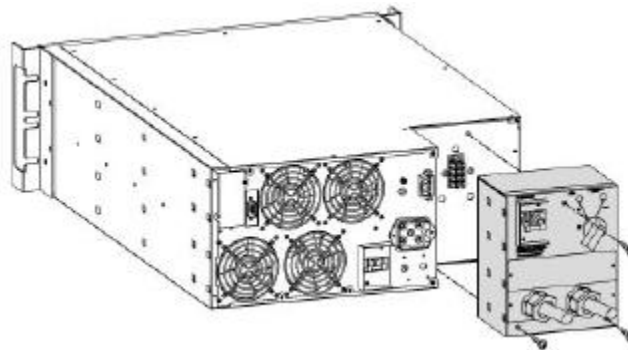

6KVA POWER UNIT SEPERATION FROM PDU

3. Loosen the 2 terminal cover screws on the back side of the PDU, slide the cover over the terminals, and re-affix the screws.



6KVA PDU TERMINAL COVER

4. The Power Module can now be replaced. If internal batteries are not at the end of life, they can be placed into the new power module.
5. Slide the PDU into the new power module and fix the 3 mounting screws.
6. Switch the UPS back to normal operation.

Power Unit Replacement – 10kVA Model

1. Switch the UPS to manual bypass.
2. Remove the 3 front covers.

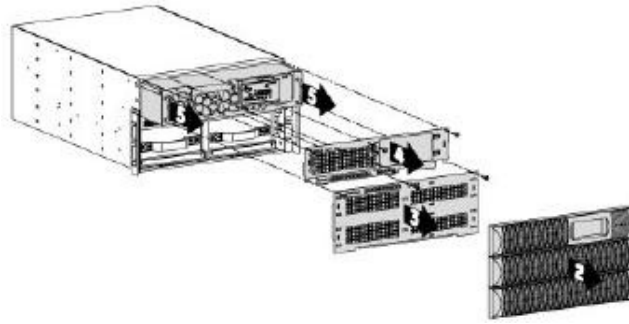

10KVA POWER UNIT REMOVAL

3. Loosen the 3 mounting screws of the internal battery cover and remove it.
4. Loosen the 5 mounting screws of the power module cover and remove it.
5. Slide the power module out of the UPS cabinet.
6. Power module can now be replaced.
7. Slide in the new power module until the rear connector of the power module is plugged into the socket on the UPS.

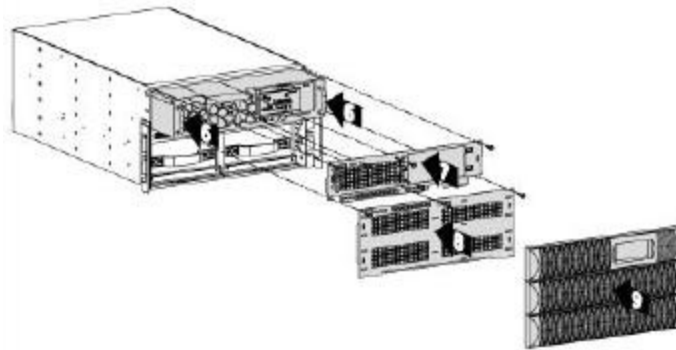

10KVA POWER UNIT REINSTALL

8. Reposition the power module cover and re-affix with the 5 screws.
9. Re-affix the 3 front covers.
10. Switch the UPS back to normal operation.

Troubleshooting

Whenever a malfunction occurs, first check external factors (e.g. connections, temperature, humidity or load) to determine whether the problem is caused by the unit itself or by its environment. Subsequently check the thermal circuit breaker: it may be tripped. If so: reset it and be sure that the UPS is not overloaded.

The following chart is a simple troubleshooting checklist. If the suggested solution does not succeed, or if the information is insufficient to solve the problem, please contact your dealer or consult www.xpcc.com.

PROBLEM	POSSIBLE CAUSE	SOLUTION
No display No alarm (UPS switched off)	Input utility switched off	Switch on input utility power
	No input utility voltage present	Inspect incoming utility circuit, consult qualified electrician
	Input fuse blown or circuit breaker tripped	Replace fuse or reset breaker
Input utility indicator not illuminating, acoustic alarm intermittent	No input utility voltage present	UPS on battery
Input utility indicator not illuminating, input utility voltage present, acoustic alarm intermittent	Input fuse blown or circuit breaker tripped	Replace fuse or reset breaker
Alarm LED illuminated, continuous acoustic alarm	UPS failure	Contact UPS dealer or go to www.xpcc.com
	UPS over temperature	Allow UPS to cool down
	Overload at UPS output	Reduce UPS load
Delivered runtime less than specified	Battery extension fuse switch is in 'Open' position	Switch to 'On' position
	Batteries are not fully charged	Charge batteries for 8 hours and reconfirm runtime
	Batteries are defective	Contact UPS dealer
	Charger is defective	Contact UPS dealer
Last load bar LED is lit, acoustic alarm intermittent	Overload at UPS output	Reduce UPS load
No communication between UPS and load	Incorrect communication cable	Check whether correct cable is used
	PC interface defective or being accessed by another service	Check if no other software is accessing the interface
	Interference on the data cable	Rearrange cables

Specifications

MODEL NUMBER		XPRT-6kVA	XPRT-10kVA
CAPACITY	Power rating	6kVA (4.2kW)	10kVA (8kW)
INPUT	Voltage	100/(173-200), 110/(190-220), 115/(198-230), 120/(208-240), 127/(220)VAC*	
	Frequency	40–70Hz	
	Power factor	> 0.97	
	Input connection	10 ft cord with L14–30P plug or hardwire	Hardwire
OUTPUT	Voltage	208/120VAC, 240/120VAC auto-sensing; 230/115VAC, 200/100VAC selectable	
	Frequency	50/60Hz auto-sensing ± 5% or frequency converter	
	Output connections	Integrated bypass/PDU with hardwired or receptacle options (options below)	
	Harmonic distortion	<3% with linear load; < 5% with non-linear load	
	Waveform	Sine wave, zero transfer time	
	Efficiency	> 92%	
	Auto restart/start on battery	Yes	
	Overload capacity	110% for 300 sec; 130% for 30 sec; 200% for 5 sec	
	Crest factor	3:1 at full load	
BATTERY	Battery quantity and size	(12) 9AH/144VDC	(24) 9AH/288VDC
	Recharge time	< 3 hours to 90%	
PHYSICAL	UPS dimensions (W x D x H)	16.9 x 22.5 x 6.9 in (4U)	16.9 x 26.0 x 10.6 in (6U)
	UPS weight	162 lbs	309 lbs
	BP dimensions (W x D x H)	16.9 x 22.5 x 3.5 in (2U)	16.9 x 26.0 x 6.8 in
	BP weight	95 lbs	200 lbs
ENVIRONMENT	Temperature	32–104°F (0–40°C)	
	Audible noise	< 55dBA	
	Altitude	11,500 ft above sea level	
APPROVALS	UL, cUL, FCC		
WARRANTY	3 years electronics, 3 years battery warranty (USA and Canada)		
COMMUNICATIONS INTERFACE	RS-232 and EBP (SNMP optional)		
AVAILABLE OPTIONS	PDUs, parallel tie/bypass panel options available		

Capacity derates in certain configurations. See user manual for more details

*Depending on load level

Shipping List

1. (1) UPS
2. (1) User's and Installation Manual
3. (1) 6 ft USB-DB9 adaptor cable
4. (1) UPS Monitoring Software CD
5. (2) sets of tower brackets
6. (2) sets of horizontal mounting brackets

Obtaining Service

If the UPS requires Service:

1. Use the TROUBLESHOOTING section in this manual to eliminate obvious causes.
2. Verify there are no circuit breakers tripped.
3. Call your dealer for assistance. If you cannot reach your dealer, or if they cannot resolve the problem, call Xtreme Power Conversion Corp Technical Support at 800.582.4524. Technical support inquiries can also be made at support@xpcc.com. Please have the following information available BEFORE calling the Technical Support Department:
 - Your name and address.
 - The serial number of the unit.
 - Where and when the unit was purchased.
 - All of the model information about your UPS.
 - Any information on the failure, including LED's that may or may not be illuminated.
 - A description of the protected equipment, including model numbers if possible.
 - A technician will ask you for the above information and, if possible, help solve your problem over the phone. In the event that the unit requires factory service, the technician will issue you a Return Material Authorization number (RMA).

If you are returning the UPS to Xtreme Power for service, please follow these procedures:

1. Pack the UPS in its original packaging. If the original packaging is no longer available, ask the Technical Support Technician about obtaining a replacement set of packaging material. It is important to pack the UPS properly in order to avoid damage in transit. Never use Styrofoam beads for a packing material.
2. Include a letter with your name, address, daytime phone number, RMA number, a copy of your original sales receipt, and a brief description of the problem.
3. Mark the RMA number on the outside of all packages. Xtreme Power cannot accept any package without the RMA number marked on the outside of the boxes.
4. Return the UPS by insured, prepaid carrier to the address provided by the Technician.
5. Refer to the Warranty statements in this manual for additional details on what is covered.

Xtreme Power Conversion Limited Warranty

Xtreme Power Conversion (XPC) Corporation warrants Xtreme Power Conversion equipment, when properly applied and operated within specified conditions, against faulty materials or workmanship (excluding batteries) for a period of **three years for XPRT-Series products** from the date of purchase. XPC Corporation warrants **internal batteries for a period of three years** from the date of purchase. For equipment sites within the United States and Canada, this warranty covers repair or replacement, at the sole discretion of XPC Corporation. The customer is responsible for the costs of shipping the defective product to XPC Corporation. XPC Corporation will pay for ground shipment of the repaired or replacement product. This warranty applies only to the original purchaser.

If equipment provided by XPC Corporation is found to be **Dead-on-Arrival (DOA)**, XPC Corporation will be responsible for the costs of shipping product to and returning equipment from the customer in a timely manner as agreed to with the customer, once the customer has requested and received a **Return Material Authorization (RMA)** number. DOA equipment is defined as equipment that does not properly function according to user documentation when initially received and connected in conjunction with proper procedures as shown in the user documentation or via support provided by XPC Corporation personnel or authorized agents.

This warranty shall be void if (a) the equipment is repaired or modified by anyone other than XPC Corporation or a XPC Corporation approved third party; (b) the equipment is damaged by the customer, is improperly used or stored, is subjected to an adverse operating environment, or is operated outside the limits of its electrical specifications; or (c) the equipment has been used or stored in a manner contrary to the equipment's operating manual, intended use or other written instructions. Any technical advice furnished by XPC Corporation or a XPC Corporation authorized representative before or after delivery with regard to the use or application of Xtreme Power Conversion equipment is furnished on the basis that it represents XPC Corporations best judgment under the situation and circumstances, but it is used at the recipient's sole risk.

EXCEPT AS STATED ABOVE, XPC Corporation DISCLAIMS ALL WARRANTIES, EXPRESSED OR IMPLIED, INCLUDING WARRANTIES OF MERCHANTABILITY AND FITNESS FOR A PARTICULAR PURPOSE.

EXCEPT AS STATED ABOVE, IN NO EVENT WILL XPC Corporation BE LIABLE FOR DIRECT, INDIRECT, SPECIAL, INCIDENTAL, OR CONSEQUENTIAL DAMAGES ARISING OUT OF THE USE OF Xtreme Power Conversion EQUIPMENT, including but not limited to, any costs, lost profits or revenue, loss of equipment, loss of use of equipment, loss of software, loss of data, cost of substitutes, or claims by third parties. Purchaser's sole and exclusive remedy for breach of any warranty, expressed or implied, concerning Xtreme Power Conversion equipment, and the only obligation of XPC Corporation under this warranty, shall be the repair or replacement of defective equipment, components, or parts; or, at XPC Corporations sole discretion, refund of the purchase price or substitution of an equivalent replacement product.

Xtreme Power Conversion Load Protection Policy

THIS POLICY IS NOT A WARRANTY. REFER TO **THE XPC CORPORATION, INC. LIMITED WARRANTY** FOR INFORMATION CONCERNING THE WARRANTY FOR YOUR XPC PRODUCT. THE LIMITATIONS AND CONDITIONS CONTAINED IN THIS POLICY DO NOT AFFECT **THE TERMS OF THE XPC LIMITED WARRANTY**.

Definitions:

1. “Product” means a Standard 120, 208, or 240 Volt power protection device that is used in the United States and Canada. This policy does not include custom manufactured products.
2. “Power Disturbance” means an AC power line transient (telephone line or Local Area Network, if applicable), spike or surge.
3. “Connected Equipment” properly connected electronic equipment
4. “Fair Market Value” of damaged Connected Equipment as determined by XPC shall be the lower of (a) the average price the same or similar items are being sold for on eBay, (b) the price list of Orion Blue Book (or if such price list is no longer published, a published or announced price list reasonably selected by XPC), (c) the lowest price the same or similar items can be purchased for in the United States or (d) the total amount of all payment(s) you have or are entitled to receive from insurance, other warranties, extended warranties, a legal liability claim or from other sources or persons for the damaged Connected Equipment.
5. “Purchaser” means the person or entity that originally purchased the Product from an authorized reseller or distributor of XPC Products.

The Purchaser of this Product is protected, for the term of the XPC Limited Warranty, against certain losses caused by a Power Disturbance for properly connected electronic equipment (referred to as the "Connected Equipment") subject to certain terms and conditions provided below.

This policy applies only to the original purchaser of the Product. If the Product is transferred or sold to another person or entity, this policy is void.

Load Protection Policy Dollar and Period Limits

For purchasers that meet the qualifications and conditions set forth in this policy, XPC will provide reimbursement (cost of repair or fair market value as determined by XPC) during the period limits and up to the dollar limits stated as follows:

PRODUCT	DOLLAR LIMIT	PERIOD OF COVERAGE
XVT	25,000	Term of XPC Limited Warranty
XST	25,000	Term of XPC Limited Warranty
S70	25,000	Term of XPC Limited Warranty
XPRT 6kVA & 10kVA	50,000	Term of XPC Limited Warranty
NXRT	50,000	Term of XPC Limited Warranty
P90, P90L, P90g, P90Lg	50,000	Term of XPC Limited Warranty
T90	50,000	Term of XPC Limited Warranty
TX90, TX90i	50,000	Term of XPC Limited Warranty

This Load Protection Policy is not deemed "first dollar" coverage. XPC’s obligation is reduced by any amounts that the Purchaser is entitled to recover, from other sources regarding the Connected Equipment, including, but not limited to, insurance, other warranty, extended warranty, or legal liability, regardless of whether or not the Purchaser makes a claim for recovery.

Eligibility for Coverage Under the Load Protection Policy

1. The Product must be registered on the XPC website, www.xpcc.com, within 10 days of purchase. All required information must be provided, and Purchaser should retain a copy for Purchaser’s records. When registering on the website, Purchaser must list all connected equipment that is directly connected to the

product. Only those devices registered in that manner will be covered.

2. All Connected Equipment must be UL or CSA approved.
3. The Product must be plugged into a properly wired and grounded outlet. Use of input surge devices, extension cords, adapters, ground wires, or electrical connections not manufactured by XPC voids the XPC Load Protection Policy. No other surge protection device may be connected to the output sockets of the Product. The installation must comply with all applicable electrical and safety codes set forth pursuant to the NEC.
4. The Product must have undeniable physical evidence of a Power Disturbance that directly and proximately caused the damage;
5. The Connected Equipment must have been damaged by a Power Disturbance on a properly installed, grounded, and National Electric Code, ("NEC"), code-compliant 120, 208, 240 Volt AC power line in the United States or Canada, by a Power Disturbance on standard telephone land line or PBX telephone equipment line that is properly installed and connected to an RJ11 port on the Product; or by a Power Disturbance on a standard Local Area Network connection that is properly installed and connected to an RJ45 port on the Product and (d) is directly plugged into, and properly connected to, the Product in its original condition which was properly operated when a Power Disturbance passed through the Product and (i) exhausts the protection capacity of the Product or (ii) damages the Product.
6. The Load Protection Policy does not apply if the Product has been operated in a failure mode or not in compliance with XPC operating instructions in the Product user's manual, or if the Connected Equipment has not been operated in compliance with the instructions and manuals of its manufacturer/vendor.
7. This policy is null and void if, XPC determines, in its sole discretion, that the Product has been tampered with or altered in any way.

What is Not Covered Under the Load Protection Policy:

The following damage is not covered by this Policy:

1. Restoration of lost data and reinstallation of software.
2. Damage from a cause other than AC power-line transients, except for damage due to telephone line, Local Area Network, or CATV transients, which is covered only if the Product offers such protection.
3. DAMAGE CAUSED BY FAILURE TO PROVIDE A SUITABLE INSTALLATION ENVIRONMENT FOR THE PRODUCT (INCLUDING, BUT NOT LIMITED TO, LACK OF A PROPER SAFETY GROUND).
4. Damage caused by the use of the Product for purposes other than those for which it was designed.
5. Damage caused by accidents, or natural disasters, including but not limited to, fire, flood, and wind.
6. Damage caused by abuse, misuse, alteration, modification, or negligence.
7. Any labor costs or travel, room and board expenses associated with the repair and/or restoration of lost or damaged hardware, software or data.

EXCEPT AS EXPRESSLY PROVIDED IN THIS POLICY, XPC SHALL NOT BE LIABLE FOR ANY DAMAGES WHATSOEVER, INCLUDING, BUT NOT LIMITED TO, DIRECT, INDIRECT, SPECIAL, INCIDENTAL, CONSEQUENTIAL, OR MULTIPLE DAMAGES ARISING OUT OF THE USE OF THE PRODUCT OR DAMAGE TO THE CONNECTED EQUIPMENT, REGARDLESS OF THE LEGAL THEORY ON WHICH SUCH CLAIM IS BASED, EVEN IF ADVISED OF THE POSSIBILITY OF SUCH DAMAGE. SUCH DAMAGES INCLUDE, BUT ARE NOT LIMITED TO, LOSS OF PROFITS, LOSS OF SAVINGS OR REVENUE, LOSS OF USE OF THE PRODUCT OR THE CONNECTED EQUIPMENT OR ANY ASSOCIATED EQUIPMENT, LOSS OF SOFTWARE, COST OF CAPITAL, COST OF ANY SUBSTITUTE EQUIPMENT, FACILITIES OR SERVICES, DOWNTIME, THE CLAIMS OF THIRD PARTIES, INCLUDING CUSTOMERS, AND INJURY TO PROPERTY.

Submitting a Load Protection Policy Claim:

1. Any claim under the Load Protection Policy must be made within 10 days of the date of alleged damage to the Connected Equipment.
2. Call the XPC technical support department at 1-800- 582-4524 and obtain a Load Protection Policy Returned Material Authorization (RMA) number. Have information on all applicable insurance or other resources of recovery/payment that is available to the Purchaser and the name of the power utility supplier for the location of the Connected Equipment. XPC will forward to the Purchaser a Load Protection Policy claims form, which

must be completed and filed with XPC within 30 days.

- Mark the Load Protection Policy RMA number on the Product the Purchaser is returning.
- Pack the Product in its original packaging or similar packing materials if the original packaging has been discarded. Enclose the completed Load Protection Policy claim form and a copy of the Purchaser's original sales receipt for the Product in the box.
- Mark the RMA number clearly on the outside of the box.
- Ship the Product (one-way shipping charges paid by the Purchaser) to:

XPC Corporation
230 Yuma Street
Denver, CO 80223
Attn: LPP RMA#

3. XPC will evaluate the Product to determine its level of functionality, and will examine the Product for evidence of damage from a Power Disturbance.
 - If XPCs' evaluation provides no evidence of damage from a Power Disturbance, XPC will send to the Purchaser (i) a report summarizing the tests performed and (ii) a rejection of claim notice.
 - If the Product shows evidence of damage from a Power Disturbance, XPC will request that all Connected Equipment for which a Load Protection Policy claim has been submitted, be sent for evaluation to either XPC or an authorized service center. If it is determined that the Connected Equipment has been damaged by a Power Disturbance, XPC will, in its sole discretion, issue payment to the Purchaser for either the cost of repair of the Connected Equipment or the Fair Market Value of the damaged Connected Equipment, up to the dollar limits stated above. XPC reserves the right to require the Purchaser to transfer title and deliver the Connected Equipment to XPC if it chooses to reimburse the Purchaser for the fair market value of the Connected Equipment. XPCs' maximum liability shall be reduced to reflect all such other payments or sources of recovery, whether applied for or not.
4. If XPC issues payment to the Purchaser to have the Connected Equipment repaired, the repair must be performed at a service center that is authorized by the manufacturer of the Connected Equipment. XPC reserves the right to contact the authorized service center directly to discuss repair costs and damage to the Connected Equipment to determine if it was caused by a Power Disturbance and the right to request that the service center forward the Connected Equipment or components of the Connected Equipment to XPC for inspection
5. Unless modified in writing signed by an officer of XPC and the Purchaser, the terms of this policy are the complete and exclusive agreement between the parties, superseding all prior agreements, oral or written, and all other communications between the parties relating to the subject matter of this agreement. No employee of XPC or any other party is authorized to make any representations beyond those made in this agreement concerning the Load Protection Policy.

XPC Corporation
230 Yuma Street
Denver, CO 80223
1.800.582.4524

Appendix A: SNMP/WEB Card (Optional)



WARNING!

The UPS contains hazardous voltages. Observe carefully the safety instructions to prevent risk of electrical shock.



CAUTION!

The SNMP/Web Card contains a lithium coin-cell battery. RISK OF EXPLOSION IF BATTERY IS REPLACED BY AN INCORRECT TYPE. DISPOSE OF USED BATTERIES ACCORDING TO LOCAL CODE AND INSTRUCTIONS.

Introduction

This addendum to the XPRT 6 / 10 kVA User’s Manual provides information on the optional SNMP/Web Card that can be used with these products.

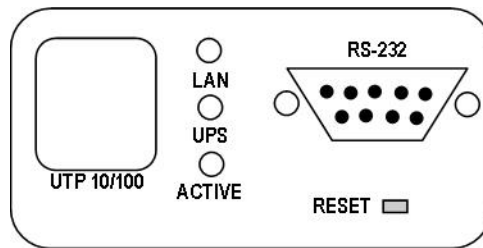

SNMP/WEB CARD FRONT VIEW

LEDs

The front panel LEDs have the following meaning:

	STATUS	MEANING
LAN/NETWORK	OFF	NO LAN CONNECTION DETECTED
	ON	LAN CONNECTION ESTABLISHED, NO COMMUNICATION
	BLINK	LAN CONNECTION ESTABLISHED, RECEIVE OR TRANSMIT ACTIVE
UPS / FAIL	OFF	OK / NO FAULT
	ON	NO UPS CONNECTION
ACTIVE	OFF	FAULT OF DEVICE
	BLINK	DEVICE OK / NO FAULT

Features

Each SNMP/Web Card provides the following features:

- 10/100 Mbps connection speed
- Use of DHCP / BOOTP or manual configuration for the TCP/IP network settings
- SNMP Agent
- Web server
- Console interface
- UPS status / alarms / readings; event logging over different interfaces
- Digital outputs (open-collector outputs for relay drive)

- SNMP Traps and E-mail notification upon UPS event
- Advanced security features

Architecture

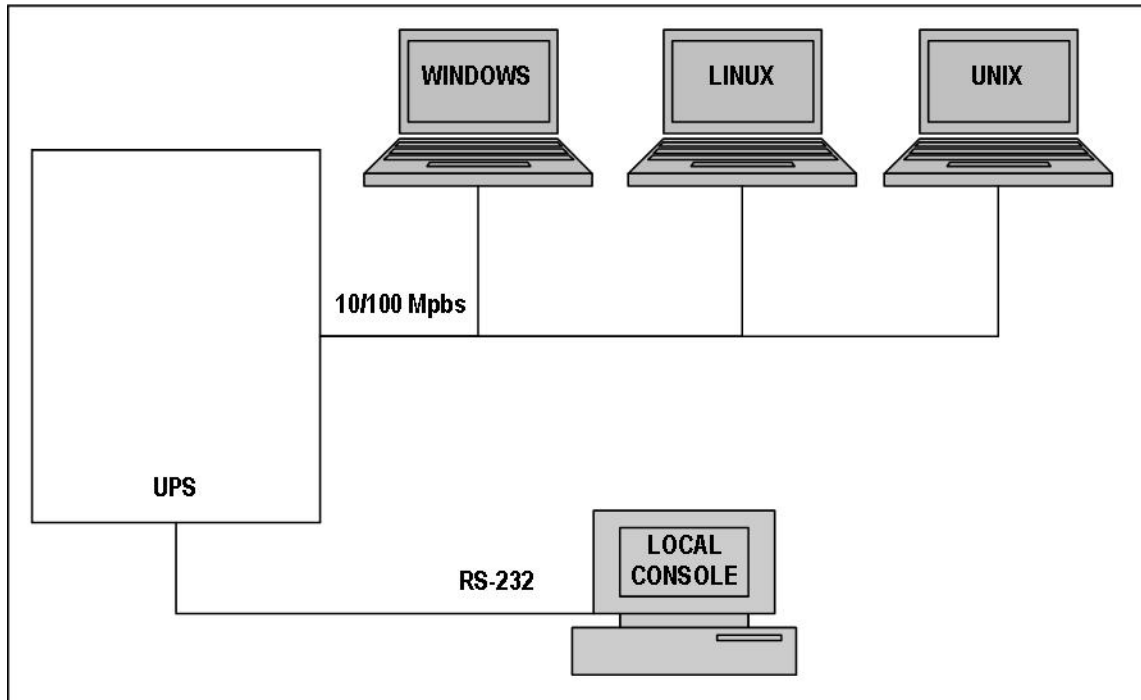

COMMUNICATIONS ARCHITECTURE

Installation



NOTE!

Strictly observe the 'UPS Safety Rules'. Read carefully the main sections of this UPS User's Manual before installing or operating the equipment. If any problems are encountered with the installation procedure, please contact the support@xppc.com before proceeding.

- Switch off the UPS, and wait for approximately 2 minutes or place the UPS into maintenance bypass. If switching to maintenance bypass, make sure the utility input voltage is stable before switching.
- Install the SNMP/Web Card in the option slot on the rear of the UPS.

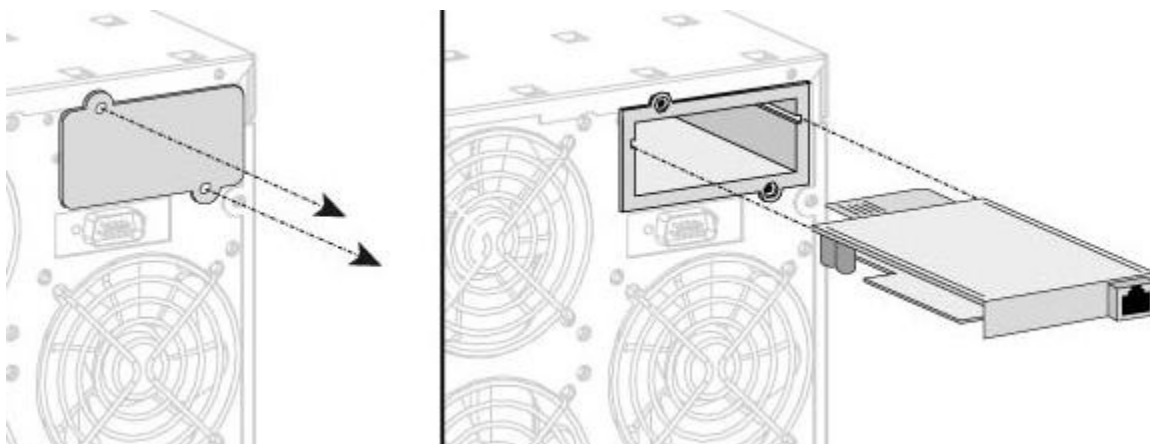

SNMP INSTALL 6kVA UPS

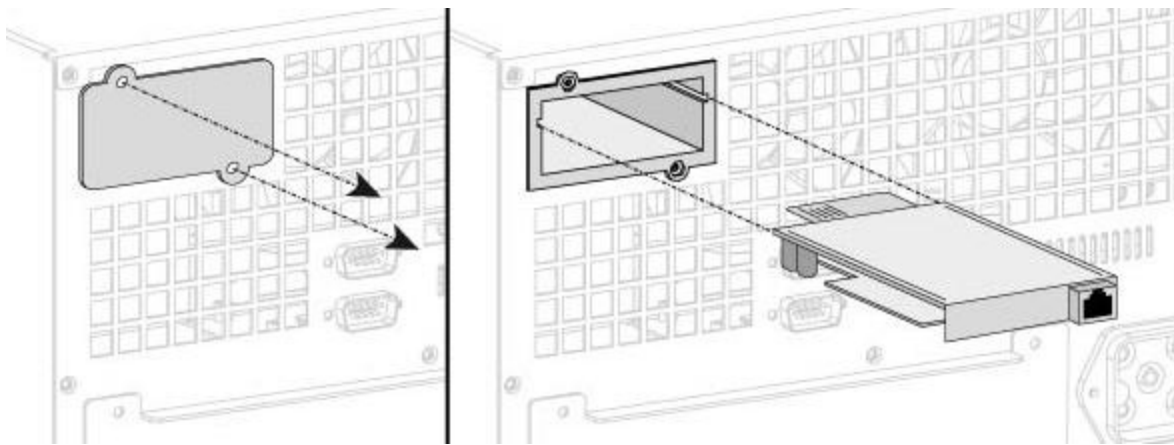

SNMP INSTALL 10kVA UPS

- Make all necessary connections (see figure on previous page).
- Switch on the UPS or go back to normal from maintenance bypass.

Interfaces

UPT 10/100 – RJ45 Port

Connection to an Ethernet 10/100 Mbps network using a UTP cable.

RS-232 – DB9 Port

Serial communication connection to a local console.
Use a straight (1:1) serial cable for connection to a PC

CONNECTOR PIN OUT AS FOLLOWS:	
PIN #	FUNCTION
2	TD – TRANSMIT DATA
3	RD – RECEIVE DATA
5	GND

Configuration

Configuration via serial connection

- Connect the SNMP/Web Card to a computer using a standard 1:1 serial communications cable.
- Run a terminal simulator (e.g. HyperTerminal on a PC running Windows).
- Configure the terminal simulator as follows:
 - o 115.200bps
 - o 8 data bits
 - o 1 stop bit
 - o parity none
 - o flow control none
 - o Terminal emulation VT-100
- Establish the connection and press <enter>
- The default username (login) and password are ge and ge
- A command-line configuration interface is entered. Type menu to enter the quick network configuration menu

Note: *Although the console interface provides a full set of commands, access using the serial connection is only needed for initial configuration when no DHCP server is available, or the IP-address is unknown. The quick network configuration menu provides a simple interface for basic network configuration. For all other settings the user-friendly web interface is recommended.*

Note: Saving the settings

Apart from some network parameters, most settings are immediately active. However, the card will revert to the last saved settings at reboot. Therefore, in order to permanently modify the SNMP/Web Card settings, remember to save the configuration after every change. This can be done by:

- Pressing S on the quick configuration menu
- Entering nvsave at the command interface prompt

Configuration via the network

TELNET

- Launch a telnet client (e.g. on a PC running Windows, select Run from the Start menu and type telnet <IP>)
- The default username (login) and password are ge and ge
- A command-line configuration interface is entered

WEB BROWSER

- Launch a web browser
- Enter the URL of the SNMP/Web Card : http://<IP>/
- The default username and password are ge and ge

Note: Saving the settings

Apart from some network parameters, most settings are immediately active. However, the card will revert to the last saved settings at reboot. Therefore, in order to permanently modify the SNMP/Web Card settings, remember to save the configuration after every change.

Network Parameters

The SNMP/Web Card connects to the network using the following parameters:

IP ADDRESS	IDENTIFIES THE CARD ON THE NETWORK
SUBNET MASK	DEFINES A RANGE OF ADDRESSES WITHIN THE ORANIZATION
GATEWAY	THE NODE USED FOR CONNECTION TO ADDRESSES OUTSIDE THE SUBNET

The card can be configured to obtain these settings automatically using DHCP or BOOTP protocols, or to use static addresses (manual configuration).

Default Configuration

The SNMP/Web Card comes with a pre-configured MAC address, with the following format:

00:12:93:fx:xx:xx 00:12:93 identifies the manufacturer
 x:xx:xx is a unique code for every card

The MAC address is written on a label sticker on the SNMP/Web Card.

The factory default configuration for the SNMP/Web Card is using DHCP. Assign the IP address to the card MAC address in your DHCP server. Then reboot the card in order to have it retrieve the IP address. The card is now accessible and configurable over the network.

Reboot

Every time the network settings are changed, these become effective only after a reboot. The card can be rebooted by:

- Manually pressing the reset button on the front of the card
- Using the console interface (either serial connection or telnet) by injecting the reboot command
- Using a web browser, selecting Reboot in the menu

Access

WEB INTERFACE

- After the installation and configuration of the SNMP/Web Card, the connection can be tested with a web browser.
- Launch the browser
- Enter the URL of the SNMP/Web Card: `http://<IP>/` (e.g. `http://192.168.24.14/`)
- When prompted, enter username and password
- The SNMP/Web Card home page will be shown

TROUBLESHOOTING

If no answer is received for the card, verify the card installation, cabling, and network configuration. Check the Ethernet connection to the card by launching a ping command from a workstation in the same subnet.

- Select Run from the Start menu
- Enter `ping <IP>` (e.g. `ping 192.168.24.14`)
- Verify that the SNMP Card is correctly replying