



E90 Online UPS

10kVA, 15kVA, 20kVA Models

User & Installation Manual

Table of Contents

Important Safety Instructions.....	3
Product Description.....	6
Summarization.....	6
Functions and Features.....	6
Installation.....	7
E90 Cabinet View Outlook.....	10
LCD control Panel.....	12
Installation Notes.....	12
External Protective Devices.....	14
Power Cables.....	14
Power Cable Connection.....	15
Duel Input Connection.....	15
EBP80 External Battery Pack Setup.....	17
UPS parallel Installation	21
Operation.....	22
Operation Modes.....	24
Turn on/off UPS.....	25
The LCD Display.....	28
Display Messages/Troubleshooting.....	41
Options	42
Problems and Solution.....	43
USB communication port definition.....	45
RS232 communication port definition.....	46
RS485 communication port definition.....	47
BAT_T communication port definition.....	48
REPO instruction.....	49
Specifications.....	50
Obtaining Service.....	57
Xtreme Power Conversion Limited Warranty.....	58

Thank you for selecting the XTREME Power Conversion E90-Series uninterruptible power supply (UPS). Please read this manual before installing the E90-Series UPS models E90-10K, E90-15K, and E90-20K as it provides important information that should be followed during installation and maintenance of the UPS and batteries, allowing you to correctly set up your system for the maximum safety and performance. Included is information on customer support and service, if it is required. If you experience a problem with the UPS, please refer to the Troubleshooting section in this manual to correct the problem. If the problem is not corrected, please collect information so that the Technical Support personnel can more effectively assist you.

Important Safety Instructions: (Save These Instructions)

SAVE THESE INSTRUCTIONS - This manual contains important instructions for Model E90 10-20K that should be followed during installation and maintenance of the UPS and batteries.

 CAUTION! (UPS having External Batteries) - To reduce the risk of fire, connect only to a DC circuit provided with 63 A DC (10kVA) or 125ADC (15kVA /20kVA) maximum branch circuit over current protection in accordance with the National Electric Code, ANSI/NFPA 70, and the Canadian Electrical Code, Part I, C22.1.

 CAUTION! (UPS having Internal Batteries): Risk of electrical shock – Hazardous live parts inside this unit are energized from the battery supply even when the input AC power is disconnected.

 CAUTION! (No User serviceable Parts): Risk of electrical shock, do not remove cover. No user serviceable parts inside. Refer servicing to qualified service personnel.

 CAUTION! (Non-isolated Battery supply): Risk of electric shock, battery circuit is not isolated from AC input, hazardous voltage may exist between battery terminals and ground. Test before touching.

 WARNING! (Fuses): To reduce the risk of fire, replace only with the same type and size of fuse.

 WARNING! Unit intended for installation in a controlled environment.

Servicing of batteries should be performed or supervised by personnel with knowledge of batteries and the required precautions. Keep unauthorized personnel away from batteries.

For Replacement of batteries located in an SERVICE ACCESS AREA

1) Servicing of batteries should be performed or supervised by personnel knowledgeable about batteries and the required precautions.

2) Risk of explosion if battery is replaced by an incorrect type. When replacing batteries, replace with the same type and number of batteries.



CAUTION: Do not dispose of batteries in a fire. The batteries may explode. Dispose of used batteries according to the instructions.



CAUTION – Do not open or mutilate batteries. Released electrolyte is harmful to the skin and eyes. It may be toxic.



CAUTION – A battery can present a risk of electrical shock and high short circuit current. The following precautions should be observed when working on batteries:

- a. Remove watches, rings, or other metal objects.
- b. Use tools with insulated handles.
- c. Wear rubber gloves and boots.
- d. Do not lay tools or metal parts on top of batteries.
- e. Disconnect charging source prior to connecting or disconnecting battery terminals.
- f. Determine if battery is inadvertently grounded. If inadvertently grounded, remove source from ground. Contact with any part of a grounded battery can result in electrical shock. The likelihood of such shock can be reduced if such grounds are removed during installation and maintenance.

These UPS units are extremely heavy. Caution should be taken in moving and positioning equipment. The instructions contained within this safety manual are deemed important and should be closely followed at all times during installation and follow-up maintenance of the UPS and batteries.

 **CAUTION**

The unit has dangerous voltages. If the UPS indicator is on, the unit's output may have a dangerous amount of voltage even when AC power is not applied because the battery may continue to supply power.

In order to reduce the risk of electric shock, UPS should be installed indoors, in an environment that is temperature and humidity controlled and free from electrically-conductive particles.

All servicing on this equipment must be carried out by qualified service personnel.

Before conducting any maintenance, repair, or shipment, first ensure that all AC and DC power is turned off completely and disconnected.

Special Symbols

The following symbols used on the UPS warn you of precautions:



RISK OF ELECTRIC SHOCK - Please observe the warning that a risk of electric shock is present



CAUTION: REFER TO OPERATOR'S MANUAL - Refer to the operator's manual for additional information, such as important operating and maintenance instructions.



SAFE GROUNDING TERMINAL - Indicates primary safe ground



Please do not discard of the UPS or the UPS batteries as the UPS may have valve-regulated lead-acid batteries. Please recycle batteries appropriately.

Summarization

The E90 series UPS is a three-phase in, three-phase out high frequency online UPS.

The UPS can solve all the power supply problems, such as AC blackout, power sag, voltage surge, brownout, over-voltage, normal mode noise, frequency variation, switching transient, and harmonic distortion.

This UPS can be applied to applications such as computer device, automatic equipment, communication systems, and industry equipment.

Functions and Features

Three-Phase In/Three-Phase Out UPS

The E90 is a three-phase in, three-phase out high-density UPS system, of which input current is kept in balance.

Digital Control

The E90 is controlled by Digital Signal Processor (DSP); hence, it increases reliability, performance, self-protection, and self-diagnostics and so on.

Charging Current is configurable

The user may set the capacity of the batteries as well as reasonable charging current as well as maximum charging current. Constant voltage mode, constant current mode or floating mode can be switched automatically and smoothly.

Intelligent Charging Method

The E90 series UPS adopts advanced three-stage charging method

1st stage: high current constant current charging to guarantee to charge back to 90%;

2nd-stage: Constant Voltage to vitalize battery and make sure batteries are fully charged

3rd stage: floating mode. To maintain charged batteries and extend battery life.

With this 3-stage charging method, it extends the life of the batteries and guarantees fast charging.

LCD Display

With LCD plus LED displays, the user may easily get UPS status and operational parameters, such as input and output voltage, frequency & load%, battery % and ambient temperature, etc...

Intelligent Monitoring Function

Via optional SNMP Card, you may remotely control and monitor the UPS.

EPO Function

The E90 series UPS may be completely shut off when the EPO is pressed. REPO function (Remote EPO) is also available.

System Configuration

The UPS device and the external batteries make up the system. Depending on the site and load requirements of the installation, additional options are available for the solution.

When planning a UPS system, the following should be taken into consideration:

- The total demand of the protected system shall dictate the output power rating (VA). Allow a margin for future expansion or calculation inaccuracies from measured power requirements.
- Backup time required will indicate the battery size needed. If the load is less than the UPS nominal power rating, then actual backup time is longer.
- The following options are available:

o Connectivity Options –SNMP/WEB/Relay card

o Extended Battery Packs -Matching battery pack configuration and maximum quantity:

10kVA Maximum 4 EBP80-63A battery packs

15/20kVA Maximum 4 EBP80-125A battery packs

See the Specification section of this manual for additional model information.

Installation

Dimension (inches)

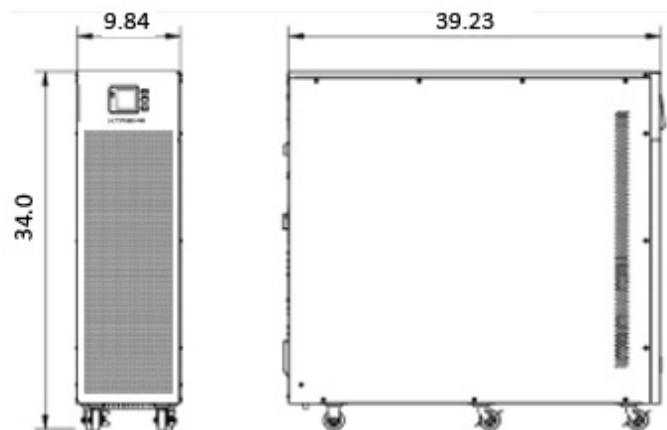

Clearances

Leave proper space around the cabinet for operation, ventilation, and service.

1. Leave at least 20" space in the front for ventilation
2. Leave at least 12" space at the back for ventilation
3. Minimum service clearance is 36" back, 36" front, and 36" sides. Manufacturer recommends using flexible conduit to allow moving UPS to provide required service clearance.

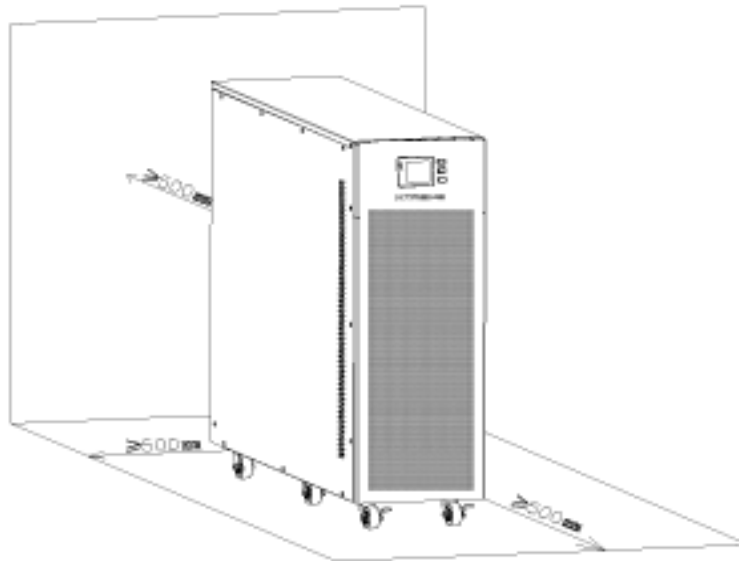
**Unpacking the UPS**

1. Don't lean the UPS when moving it out from the packaging
2. Visually inspect after unpacking to see if the UPS was damaged during transportation. Do not switch on the UPS if any damage found. Please contact the dealer right away.
3. Check the accessories according to the packing list and contact the dealer in case of missing parts.

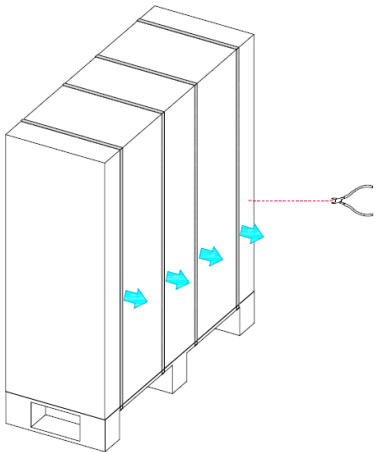

1. Cut off the bandage and remove outer packaging

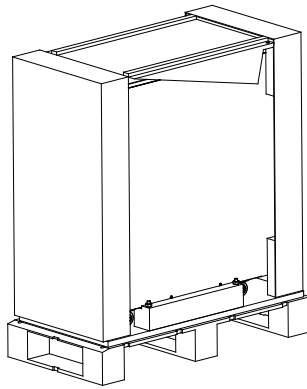

2. Remove inner packaging

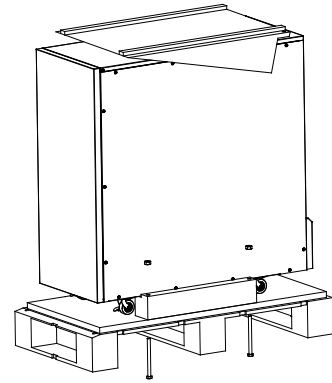

3. Unfasten the screws and remove the fixed wooden bar to the cabinet.

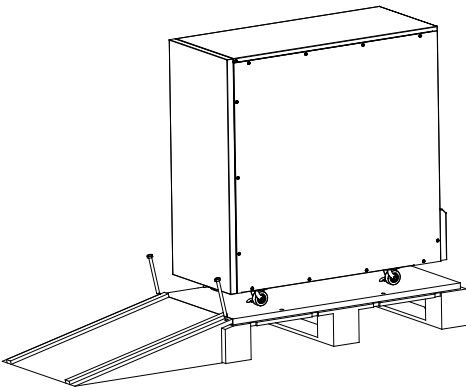

4. Place the incline board to the ground, use the screws unfastened from the last step to fasten the incline board with pallet.

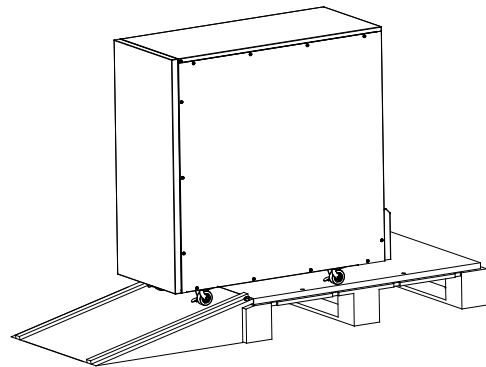

5. Slowly slide down the cabinet from pallet.

E90 Cabinet View Outlook

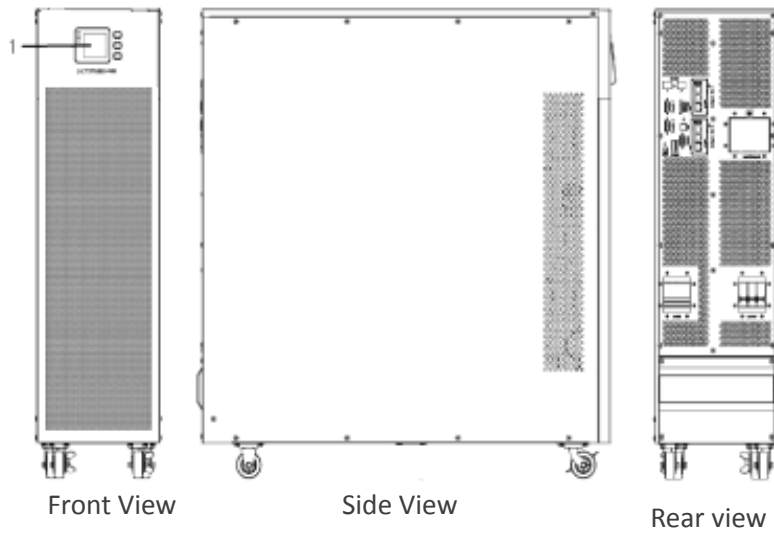

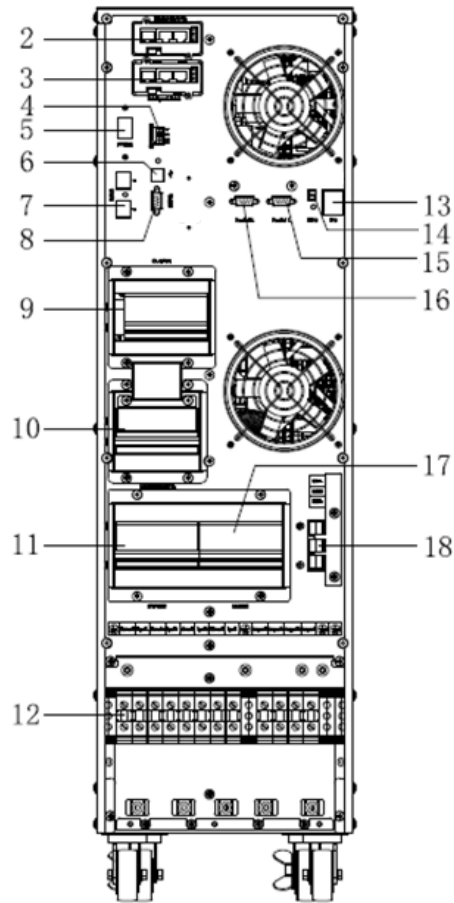

Rear View (without terminal block cover)

(1) LCD panel	(2) Intelligent Slot 1 (SNMP card/ Relay card)
(3) Intelligent Slot 2 (SNMP card/ Relay card)	(4) Dry contact output port
(5) Power Switch	(6) USB port
(7) RS485 port	(8) RS232 port
(9) Output Switch	(10) Maintenance switch & its cover
(11) Bypass Switch	(12) Terminal block for Input, output & GND
(13) EPO switch	(14) REPO port
(15) Parallel port 2	(16) Parallel port 1
(17) Mains Input Switch	(18) Terminal block for external battery*

* Note: 10kVA has only one set of Terminal block for external battery (18)

LCD control panel

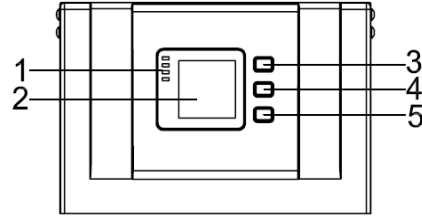

LCD control panel introduction

Number	Feature
1	LED (from top to bottom: "alarm", "bypass", "battery", "inverter")
2	LCD display
3	scroll button
4	ENTER button
5	On button (battery cold start switch)

Installation notes

Please place the UPS in a clean, stable environment. Avoid vibration, dust, humidity, flammable gas, liquids, and corrosives. Avoid high room temperature, room should be temperature controlled.

The environment temperature around UPS should be kept in a range of 0°- 40°C. If the environment temperature exceeds 40°C, the rated load capacity should be reduced by 12% per 5°C. The max temperature can't be higher than 50°C.

Batteries should be mounted in an environment where the temperature is within the required specs. Temperature is a major factor in determining battery life and capacity. In a normal installation, the battery temperature is maintained between 15°C and 25°C. Keep batteries away from heat sources.



WARNING!

Typical battery performance data are quoted for an operating temperature between 20°C and 25°C. Operating it above this range will reduce the battery life while operation below this range will reduce the battery capacity.

If the equipment is not to be installed immediately it must be stored in a room so as to protect it against excessive humidity and or heat sources.



CAUTION!

A stored battery must be recharged every 6 months. Temporarily connecting the UPS to a suitable AC supply mains and activating it for the time required to recharge the batteries may be required.

The highest altitude that UPS may work normally with full load is 1500 meters. The load capacity should be reduced when this UPS is installed in place whose altitude is higher than 1500 meters, shown as the following table: (Load coefficient equals max load in high altitude place divided by nominal power of the UPS)

Altitude(m)	1500	2000	2500	3000	3500	4000	4500	5000
Load coefficient	100%	95%	90%	85%	80%	75%	70%	65%

The UPS cooling is depending on fan, so it should be kept in well ventilated area. There are many ventilation holes on the front and rear, so they should not be blocked by any external obstacles.

External Protective Devices

For safety reasons, it is necessary to install an external circuit breaker at the input AC utility and to the battery.

External Protective Devices

For safety reasons, it is necessary to install an external circuit breaker at the input AC utility and to the external battery.

External Battery

The UPS and its associated batteries are protected against the effect of over-current through a DC compatible thermo-magnetic circuit breaker located close to the battery.

UPS Output

Any external distribution board used for load distribution shall be fitted with protective devices so as to avoid the risk of UPS overload.

UPS Input

A protection device shall be installed at the distribution panel of the incoming utility power, and should match the input requirements and the overload capacity of the system.



CAUTION!

Select a thermo-magnetic circuit-breaker with an IEC 60947-2 trip curve D (normal) for 125% of the current as listed below.

10Kva: 40A Input Circuit Breaker required. *

15Kva: 60A Input Circuit Breaker required.

20Kva: 80A Input Circuit Breaker required.

* If the battery charger current is to be programmed to 15A or higher, increase the 10kVA input circuit breaker to 45A

Power Cables

The cable design shall comply with the voltages and currents provided in this section, and in accordance with local electrical codes.



WARNING!

UPON STARTING, PLEASE ENSURE THAT YOU ARE AWARE OF THE LOCATION AND OPERATION OF THE EXTERNAL CIRCUIT BREAKERS WHICH ARE CONNECTED TO THE UPS INPUT/BYPASS SUPPLY OF THE UTILITY DISTRIBUTION PANEL.

CHECK TO SEE THAT THESE SUPPLIES ARE ELECTRICALLY ISOLATED, AND POST ANY NECESSARY WARNING SIGNS TO PREVENT ANY INADVERTENT OPERATION

UPS MODEL	CABLE SIZES (THHW wiring at 75°C)			
	AC INPUT	AC OUTPUT	DC INPUT	GROUNDING
10kVA	8 awg	8 awg	6 awg	8 awg
15kVA	6 awg	6 awg	2*6 awg	6 awg
20kVA	4 awg	4 awg	2*6 awg	4 awg

Recommended installed screw torque

	Position		
	ACINPUT	ACOUTPUT	GROUNDING
Screw type	M6	M6	M6
Recommended torque(Nm)	6.5	6.5	6.5



CAUTION!

Protective earth ground cable: connect each cabinet to an earth ground, following the shortest route possible.



WARNING!

FAILURE TO FOLLOW ADEQUATE GROUNDING PROCEDURES MAY RESULT IN ELECTROMAGNETIC INTERFERENCE OR IN HAZARDS INVOLVING ELECTRICAL SHOCK AND FIRE.

Single UPS Installation

Power cable connection

Once the equipment has been finally positioned and secured, connect the power cables as described in the following procedure.

Verify the UPS is totally isolated from its external power source and also all power isolators of the UPS are open. Check to see if they are electrically isolated, and post any necessary warning signs to prevent their inadvertent operation.

Remove the cover over terminal block to access terminals.

Common input connection

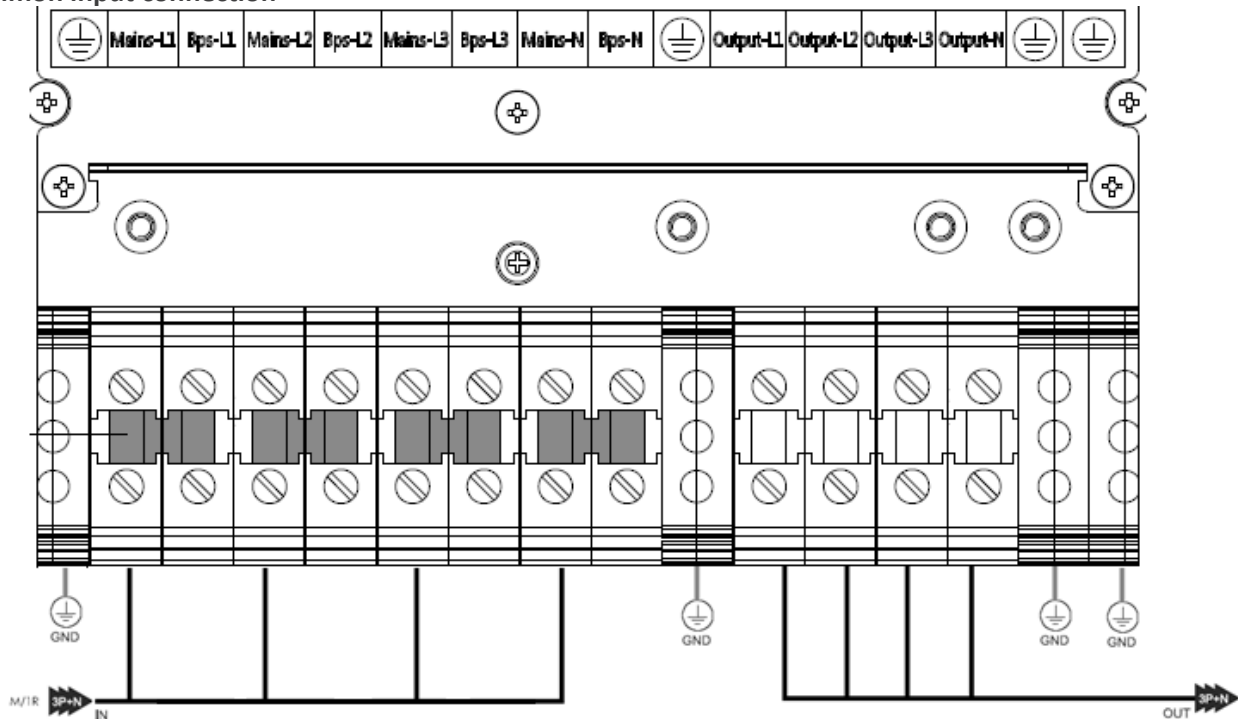

IN: Primary input Line	OUT: Output line
Input -L1: Primary input Phase L1	Output-L1: Output Phase L1
Input -L2: Primary input Phase L2	Output-L2: Output Phase L2
Input -L3: Primary input Phase L3	Output-L3: Output Phase L3
Input-N: Input Neutral	Output-N: Output Neutral
GND: Ground	GND: Ground

Dual input connection

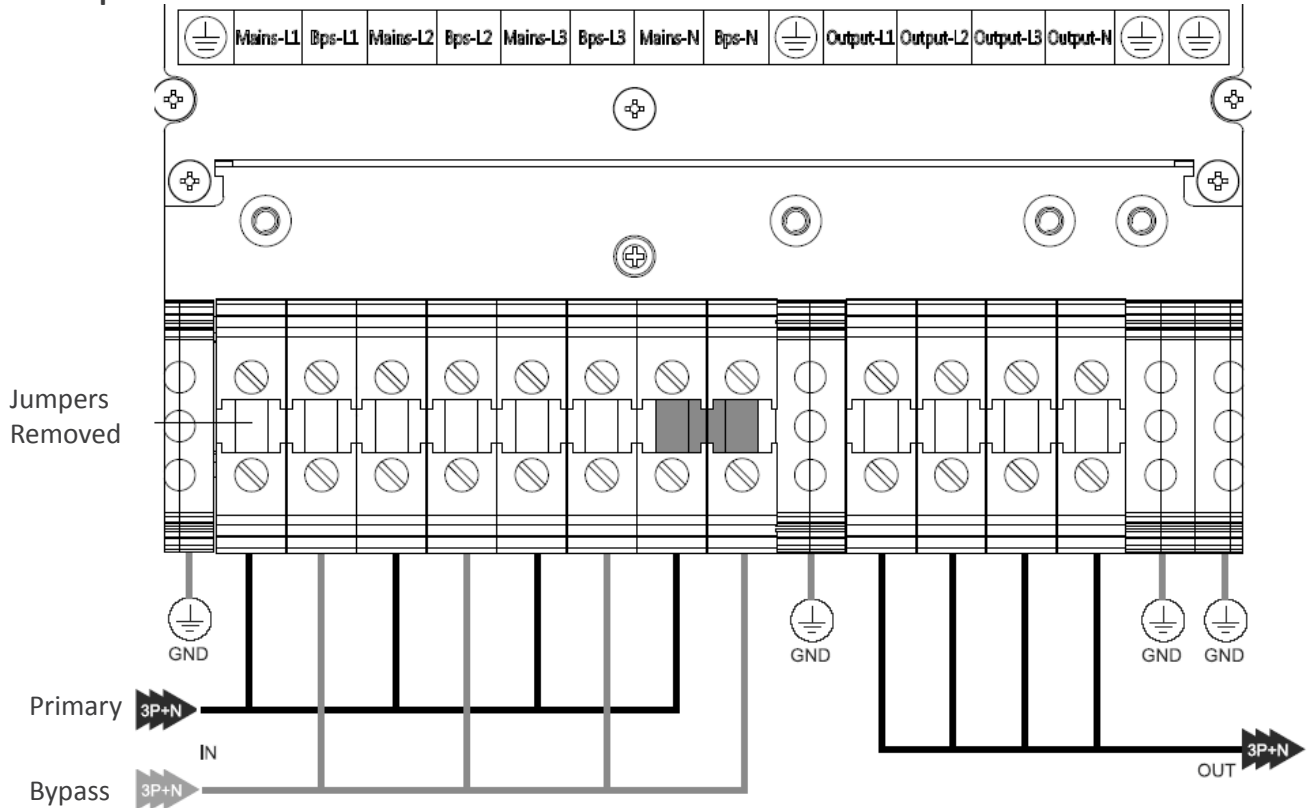

IN: Primary Input Line	OUT: Output line
IN Bypass: Bypass input line (optional)	Output-L1: Output Phase L1
Mains-L1: Primary input Phase L1	Output-L2: Output Phase L2
Mains-L2: Primary input Phase L2	Output-L3: Output Phase L3
Mains-L3: Primary input Phase L3	Output-N: Output Neutral
Input-N: Primary Input Neutral	GND: Ground
GND: Primary Input Ground	
Bps-L1: Bypass input Phase L1	
Bps-L2: Bypass input Phase L2	
Bps-L3: Bypass input Phase L3	
Bypass-N: Bypass Input Neutral	
GND: Bypass Input Ground	

**Warning**

In the case of “separate bypass and rectifier inputs” operation, make sure the copper jumpers between each input lines have been removed. The AC input and the AC bypass supplies must be referenced to the same neutral point.



WARNING! - If the load equipment is not ready to accept power prior to the arrival of the commissioning engineer then ensure that the system output cables are safely isolated.

**CAUTION!**

Connect the safety earth and any necessary bonding earth cables to the GND terminals. All cabinets in the UPS must be grounded properly. The earthing and neutral bonding must be in accordance with local and national codes.

EBP80 External Battery Pack Setup**Unpacking & Inspection**

Attention: Any damage to packing should be noted at the time of receipt with the delivery carrier

Note: The battery packs are very heavy, be cautious when unpacking and lifting the unit to avoid injury.

1. Don't lean the battery pack when moving it out from the packaging
2. Visually inspect after unpacking to see if the battery pack was damaged during transportation. Do not connect the battery pack to the UPS if any damage found. Please contact the dealer right away.
3. Check the accessories according to the packing list and contact the dealer in case of missing parts.

Remove the battery pack from the packaging.

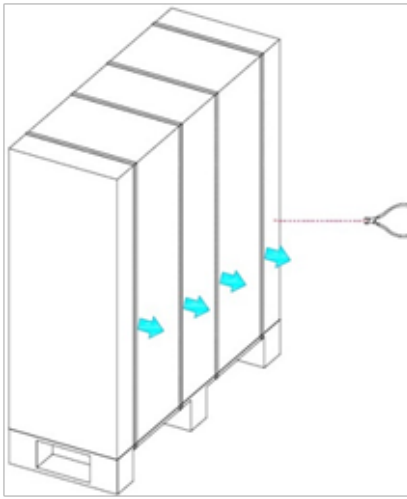

1. Cut off the banding and remove outer packaging

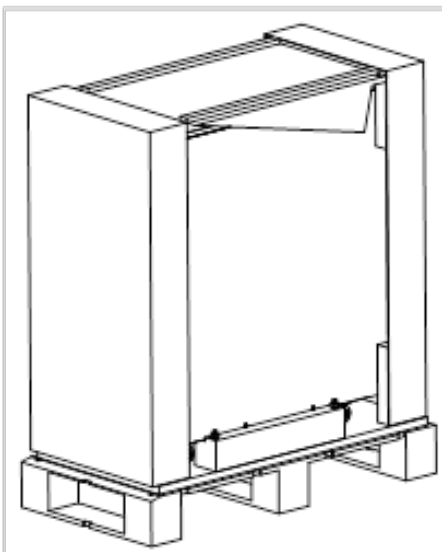

2. Remove inner packaging

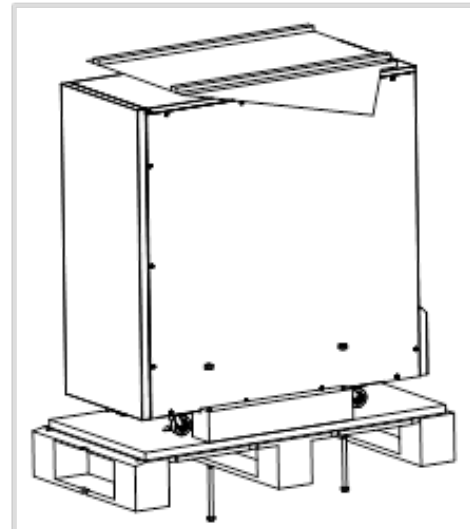

3. Unfasten the screws and remove the wooden spacer between the UPS and pallet.

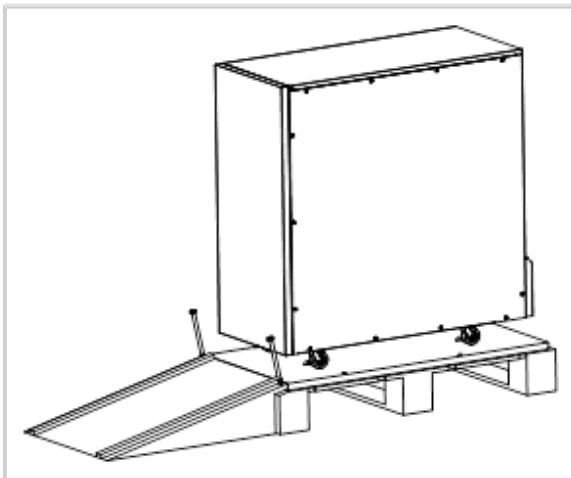

4. Place the ramp from the pallet to the ground. Use the screws unfastened from the last step to fasten the ramp to the pallet.

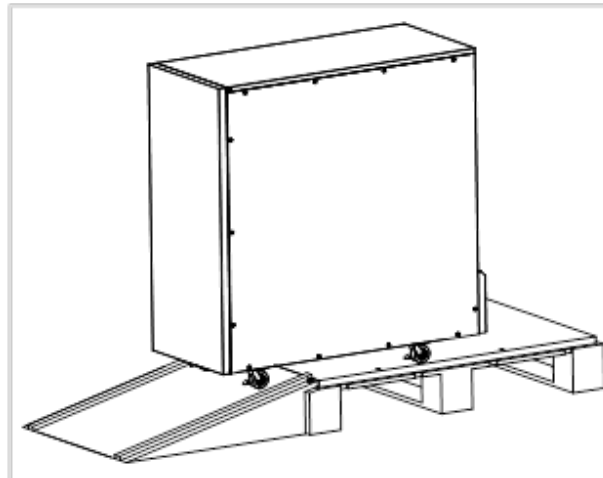

5. Slowly slide the cabinet off the pallet and down the ramp.

EBP80 External Battery Pack Dimensions

The dimensions of E90 series battery pack is 9.8 x 39.2 x 34.0 in (W x D x H).

The battery pack includes battery cables, breaker, fuses and terminals, and 80pcs of 12V/9AH batteries.

The 80 batteries are connected to be four strings of 20 batteries. The DC voltage is $\pm 120V$ DC, which consists of BAT+, N, and BAT-. The figure below shows the overall chassis



EBP80 External Battery Pack Installation



CAUTION! - Ensure correct polarity of the battery string series connection. DO NOT mix batteries with different capacity or different brands, or new and old batteries.



WARNING! - ENSURE CORRECT POLARITY OF STRING CONNECTIONS TO THE BATTERY CIRCUIT BREAKER, AND FROM THE BATTERY CIRCUIT BREAKER TO THE UPS TERMINALS (I.E. + TO + / - TO - / N TO N).

Installation and Setup

Note: Before installation, please inspect the unit. Verify that nothing inside the package is damaged.

Please keep the original packing material in a safe place for future use.

Selecting Installation Position

It is necessary to select a proper environment to install the unit, in order to minimize the possibility of damage to the battery system and extend the life of the batteries. Please follow the instructions below:

1. Do not block the air-flow to the ventilation openings of the unit.
2. Please ensure the installation site environmental conditions are in accordance with the unit's working specifications to avoid overheat and excessive moisture.
3. Do not place the unit in a dusty or corrosive environment or near any flammable objects.
4. This unit is not designed for outdoor use.

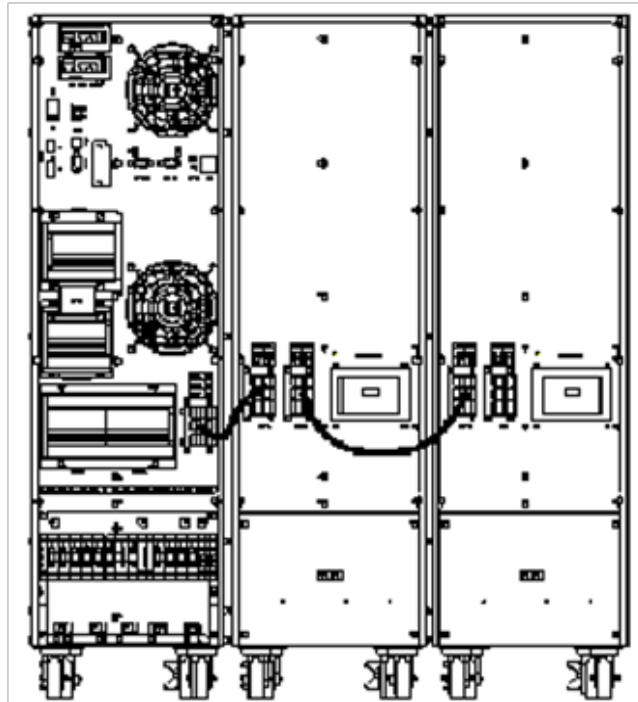

E90 10-20kVA to EBP80-63A/
EBP80-125A battery connection

Battery Pack Setup

E90 10-20kVA to EBP80-63A/EBP80-125A battery connection

Position the external battery packs as close as possible to the UPS. If multiple external battery packs are to be connected, position all external battery packs side by side.

The E90 10kVA and the E90 EBP80-63A External Battery Pack use a single DC cable between the UPS terminal block for battery and the battery pack or from battery pack to battery pack.

The E90 15/20kVA and the E90 EBP80-125A External Battery Pack use two parallel DC cables between the UPS terminal blocks for battery and the battery pack or from battery pack to battery pack.

Connect one end of each supplied cable(s) to the UPS terminal block(s) for battery and the other end to the external battery pack.

If connecting multiple external battery packs, continue this from battery cabinet to battery cabinet.

3rd party external battery connection

The UPS DC bus voltage is +/- 120VDC. The external battery must consist of one or more strings of 20 batteries each. Each string of batteries must have a center-tap between the 10th and 11th battery to be connected to the UPS neutral. The external battery must provide overcurrent protection for all three cables to be connected to the UPS. The three connections will be BAT +, N, and BAT -. The illustration below shows the configuration required.

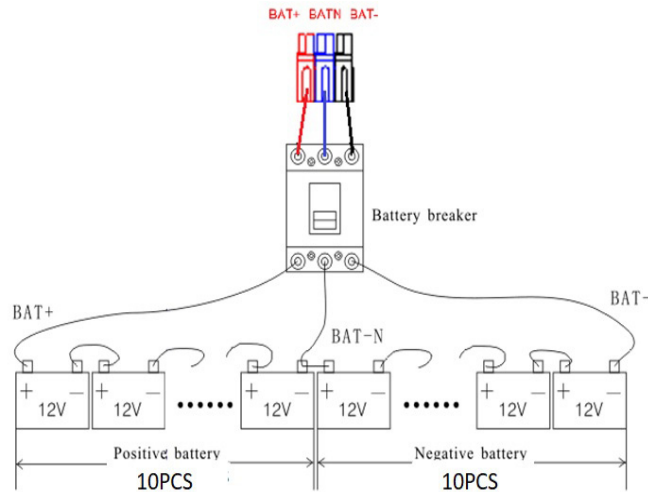

CAUTION!

Ensure correct polarity battery string series connection. I.e. inter-tier and inter block connections are from (+) to (-) terminals. DO NOT mix batteries with different capacity or different brands, or new and old batteries.



WARNING! - Ensure correct polarity of string end connections to the Battery Circuit Breaker and from the Battery Circuit Breaker to the UPS terminals i.e. (+) to (+) / (-) to (-)

UPS parallel Installation

Requirement for the parallel system

The paralleled UPS behaves as one large UPS system but with the advantage of presenting larger capacity and higher reliability. In order to assure that all UPS are equally utilized and comply with relevant wiring rules, please follow the requirements below:

- 1) All UPS must be of the same rating and be connected to the same bypass source.
- 2) The outputs of all the UPS must be connected to a common output bus.
- 3) The length and specification of power cables including the bypass input cables and the UPS output cables should be the same. This facilitates load sharing when operating in bypass mode.
- 4) Each UPS must be programmed via the front panel to enable parallel operation

Cabinet installation

Connect all the UPS to be put into parallel per the picture below picture.

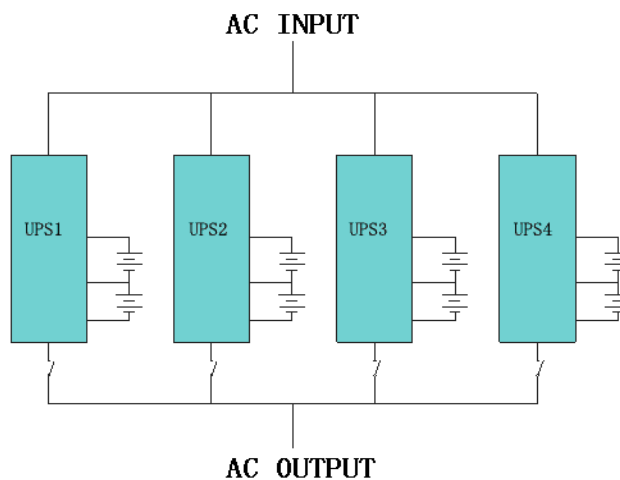

Make sure each UPS input breaker is in “off” position and there is no output from each UPS connected. Battery groups can be connected separately or in parallel, which means the system itself provides both separate battery and common battery.



WARNING!

Make sure the N, L1, L2, L3 lines are connected correctly and in phase.

Parallel cable installation

Shielded and double insulated communication cables must be interconnected in a ring configuration between UPS units as shown below. The ring configuration ensures high reliability of the control.

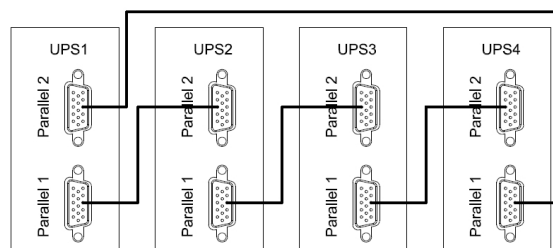

Operation

Operation Modes

The UPS is a double-conversion on-line UPS that may operate in the following alternative modes:

Normal mode

The rectifier/charger derives power from the AC Mains and supplies DC power to the inverter while floating and boost charging the battery simultaneously. Then, the inverter converts the DC power to AC and supplies AC power to the load. The power flow diagram is below

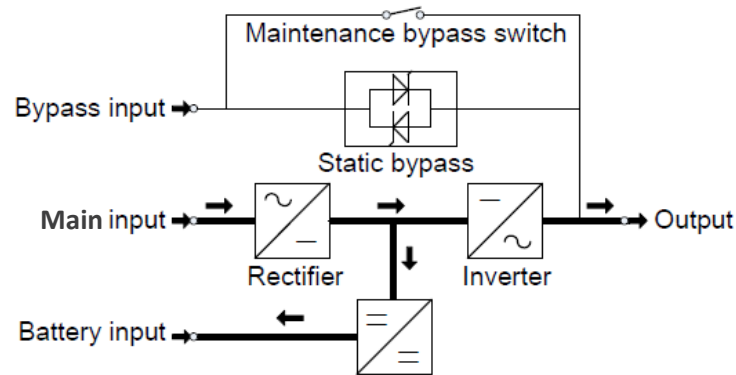

Battery mode (Stored Energy Mode)

If the AC mains input power fails, the inverter, which obtains power from the battery, supplies the critical AC load. There is no power interruption to the critical load. The UPS will automatically return to Normal Mode when AC recovers. The power flow diagram is below.

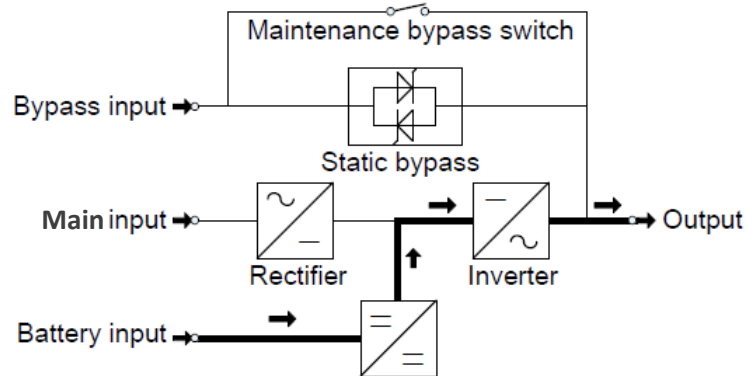

Static Bypass mode

If the inverter is out of order, or if overload occurs, the static transfer switch will be activated to transfer the load from the inverter supply to bypass supply without interruption to the critical load. In the event that the inverter output is not synchronized with the bypass AC source, the static switch will perform a transfer of the load from the inverter to the bypass with power interruption to the critical AC load. This is to avoid paralleling of unsynchronized AC sources. This interruption is programmable but typically set to be less than an electrical cycle e.g. less than 20ms (50Hz) or less than 16.66ms (60Hz). The power flow diagram is below.

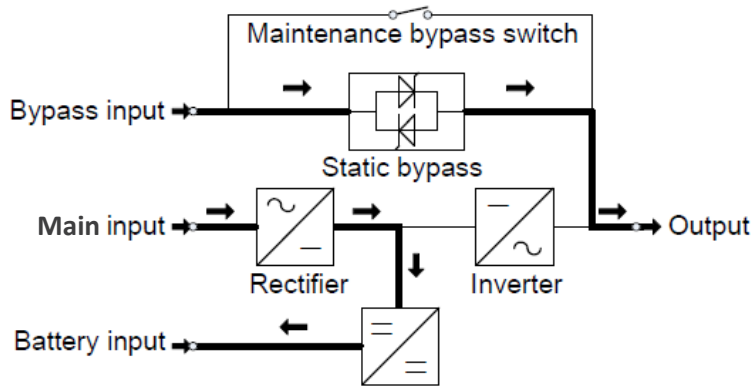

ECO Mode

When the UPS is on AC Mode and the requirement to the load is not critical, the UPS can be set at ECO mode in order to increase the efficiency of the power supplied. At ECO mode, the UPS works in Line-interactive mode, so the UPS will transfer to bypass supply when the bypass input is within the set window . When the bypass input is out of set window, the UPS will transfer from bypass to Inverter and supplies power from the battery, and then the LCD shows all related information on the screen. The ECO mode is enabled as default. The power flow diagram is below.

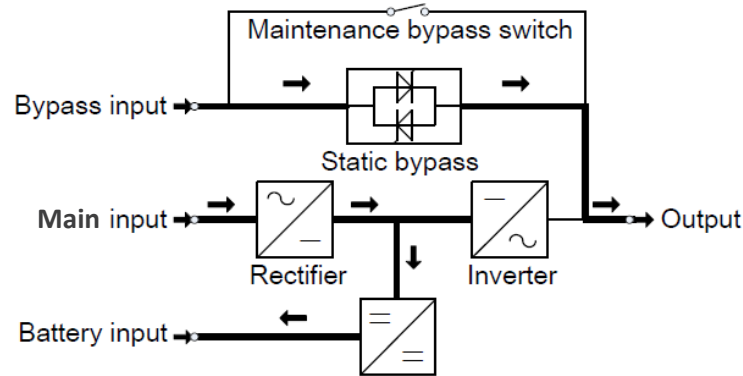

Maintenance mode (Manual Bypass)

A manual bypass switch is standard to ensure continuity of supply to the critical load when the UPS is out of order or being serviced. A micro-switch below the bracket covering the maintenance bypass switch will force the UPS into static bypass mode to ensure the maintenance bypass supply and UPS output are in phase when switching to maintenance mode. The power flow diagram is below.

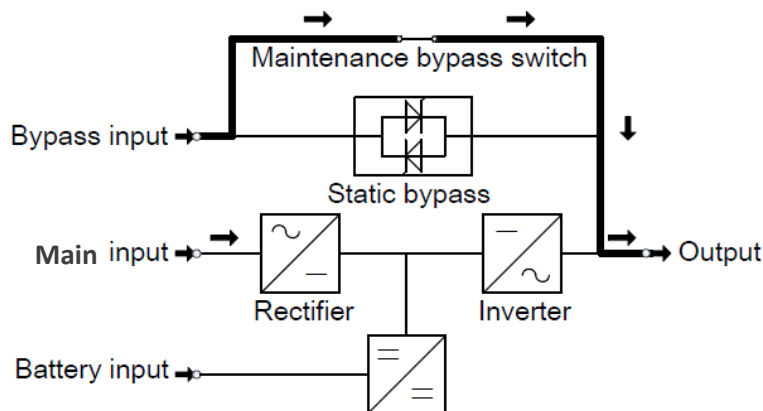

Turn on/off UPS

Start procedure

**CAUTION!**

Make sure grounding is properly done!

**CAUTION!**

Check to see if the load is safely connected with the output of the UPS. If the load is not ready to receive power from the UPS, make sure that it is safely isolated from the UPS output terminals

- 1) Switch ON UPS Main switch
- 2) If the mains input is within voltage range, the rectifier will start up in 30 seconds then the inverter will start up.
- 3) Switch ON UPS output switch.
- 4) If the rectifier fails at startup, the bypass LED will light up. When the inverter starts up, the UPS will transfer from bypass mode to inverter mode, and then the bypass LED extinguishes and the inverter LED lights up. No matter whether the UPS working normally or not, all the status will be shown on the LCD display.

Test procedure

**CAUTION!**

The UPS is operating normally. It may take 60 seconds to boost up the system and perform self-test completely

- 1) Switch off the MAINS to simulate utility failure, the rectifier will turn off and the battery should feed the inverter without interruption. At this time, the battery LED should turn on.
- 2) Switch on the MAINS to simulate utility recovery, the rectifier will restart automatically after 20 seconds and the inverter will supply to the load. It is suggested to use testloads for testing. The UPS can be loaded up to its maximum capacity during load test if the utility input breaker is sized to support the UPS at maximum capacity and the load .

Maintenance Bypass

To supply the load via Mains, you may simply activate the internal mechanical bypass switch.

CAUTION!

The load is not protected by the UPS when the internal mechanical bypass system is active and the power is not conditioned.

Switch to Maintenance Bypass

- 1) Open the cover of maintenance switch, the UPS turns to bypass mode automatically.
- 2) Turn on MAINTENANCE breaker.
- 3) Switch OFF the MAINS breaker.
- 4) Switch OFF OUTPUT breaker.

At this time the bypass source will supply to the load through the MAINTENANCE breaker.

Switch to normal operation (from Maintenance Bypass)

CAUTION!

Never attempt to switch the UPS back to normal operation until you have verified that there are no internal UPS faults

- 1) Switch ON the OUTPUT breaker.
- 2) Switch ON the MAINS breaker. The UPS powers from the static bypass instead of the maintenance bypass, and the bypass LED will light up.
- 3) Switch OFF the maintenance bypass breaker, then the output is supplied by the static bypass of the UPS.
- 4) Put on the maintenance switch cover.
- 5) The rectifier will operate normally after 30 seconds. If the inverter works normally, the system will be transferred from bypass mode to normal mode.

Cold start procedure

⚠ CAUTION!

Follow these procedures to start the UPS when the input AC Utility fails, but battery is normal

- 1) Switch ON the power switch (power will feed to auxiliary power board).

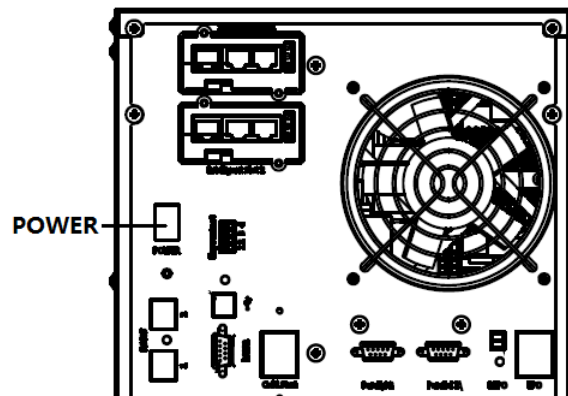

- 2) Press the cold start button as indicated by number 5 of the below drawing.

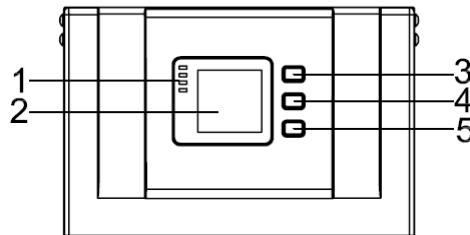

- 3) When battery is normal, the inverter starts and operates and battery LED turns on

Shut down procedure:



CAUTION!

This procedure should be followed to completely shut down the UPS and the LOAD. After all power switches, isolators and circuit breakers are opened, there will be no output.

From the On-line mode:

- 1) Press OFF to shut down the UPS. The shutdown process will take about 30s.
- 2) Switch OFF the MAINS breaker.
- 3) Switch OFF the OUTPUT breaker. The UPS shuts down;
- 4) To completely isolate the UPS from AC Mains, all input switches of Utility shall be completely off.
- 5) The primary input distribution panel is often located far away from the UPS area. A label should be posted to advise service personnel that the UPS circuit is under maintenance.
- 6) Press OFF to shut down the UPS. The shutdown process will take about 30s.
- 7) Switch OFF the OUTPUT breaker. The UPS shuts down.



WARNING!

Wait for about 5 minutes for the internal D.C. bus bar capacitors to be completely discharged.

The LCD Display

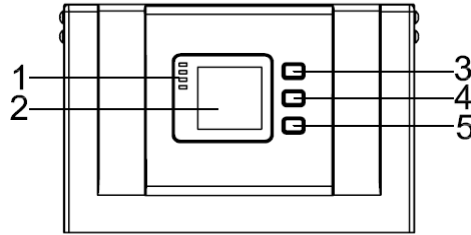

Overview of the operating panel of the UPS

Number	Feature
1	LED (from top to bottom: "alarm", "bypass", "battery", "inverter")
2	LCD display
3	scroll button
4	ENTER button
5	On button (battery cold start switch)

Introduction

The display provides more functions than those described in this manual.

CAUTION!

The setting of most parameter cannot be set when the UPS is in inverter mode.

Main Page: default display

The main data page is shown below. The display can be changed to view other data or information, view or change settings, or view records. Press the scroll key to highlight the other choices on the right side of the screen and press the enter key to enter the highlighted page.

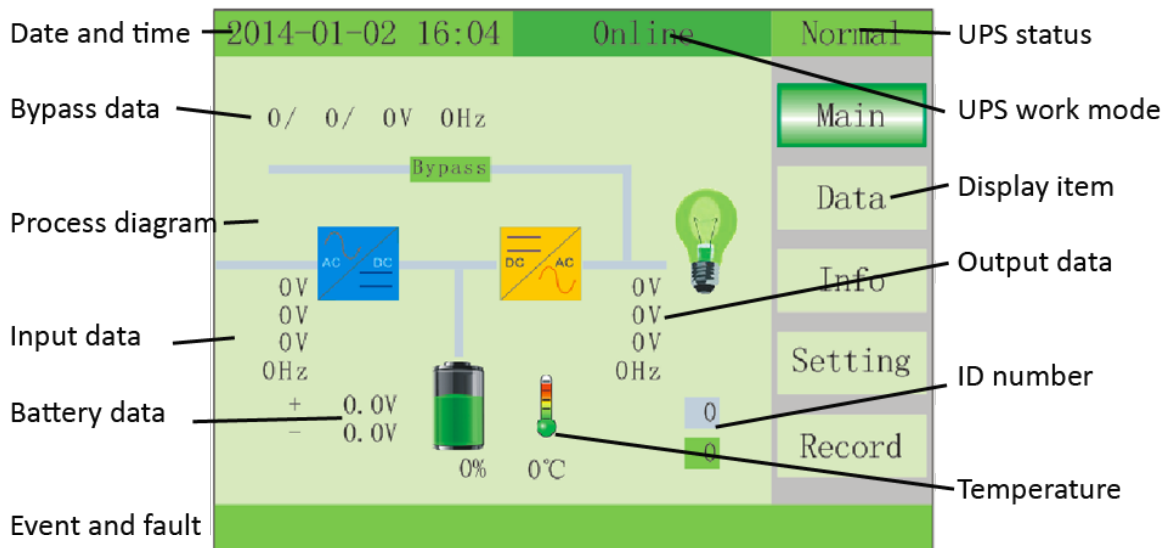

Data : Press the scroll key for approximately 1 sec. to highlight Data. The Data page will display all three phases of input and output voltage, current, and frequency and output load percentage as shown below.

2014-01-02 16:04	Online	Normal
Data-Input		
V	120.0	120.0 120.0V
I	0	0 0A
F	60.0Hz	
Data-Output		
V	120.0	120.0 120.0V
I	0	0 0A
F	60.0Hz	
load	0	0 0%

While in the Data page, additional data pages to view will be shown on the right side of the screen.

Input: Press ENTER key for approximately 1 sec. The display will show all three phases of the Main voltage, current, and frequency and the Bypass voltage and frequency as shown below.

2014-01-02 16:04		Online		Normal
Data-Main				
V	120.0	120.0	120.0V	Input
I	0	0	0A	Output
F	60.0Hz			Battery
Data-Bypass				
V	120.0	120.0	120.0V	Load
F	60.0Hz			Inside

Output: Press the scroll key for approximately 1 sec. The display will show all three phases of the Output voltage, current, and frequency as shown below.

2014-01-02 16:04		Online		Normal
Data-Output				
V	120.0	120.0	120.0V	Input
I	0	0	0A	Output
F	60.0Hz			Battery

Battery: Press scroll key for approximately 1 sec. The display will show the Battery voltage, current, estimated battery runtime and battery capacity as shown below.

2014-01-02 16:04		Online		Normal
Data-Battery				
V	+120	-120V		Input
I	0	0A		Output
Time	0	0min		Battery
CaP.	0	0%		Load
				Inside

Load : Press the scroll key for approximately 1 sec. The display will show all three phases of the Load %, kW, and kVA as shown below

2014-01-02 16:04		Online		Normal
Data-Load				
%	0	0	0%	Input
P	0	0	0kW	Output
S	0	0	0kVA	Battery
				Load
				Inside

INSIDE: press ↻ key for approximately 1 sec. to move to the fifth page, the fifth page of data is Inside data.

Inside: Press the scroll key for approximately 1 sec. The display will show the internal V-BUS (DC bus voltage), T1/T2 (Temperature 1 and Temperature 2), V-Inv (Inverter Voltage), and F-Inv (Inverter Frequency) as shown below.

2014-01-02 16:04		Online	Normal
Data-Inside			
V-Bus	+ 250	- 250V	Input
T1/T2	PFC:69	INV:69°C	Output
V-Inv	0	0	0V
F-Inv	0Hz		Battery
			Load
			Inside

Info: Press the scroll key for approximately 3 sec. to exit Data, and press the scroll key for approximately 1 sec. move to Info. The display will show LCD, PFC, and INV software versions and power rating as shown below.

2014-01-02 16:04		Online	Normal
Information			
LCD Ver.	V004B001D000		Main
PFC Ver.	V001B345D000		Data
INV Ver.	V001B345D000		Info
Power	10.0kVA		Setting
			Record

Setting: Press the scroll key for approximately 1 sec. to move to the setting page, then press ENTER key to enter setting-user page. Press the scroll key to change item, press ENTER key to enter item and press the scroll key to change value, press ENTER key confirm the setting.

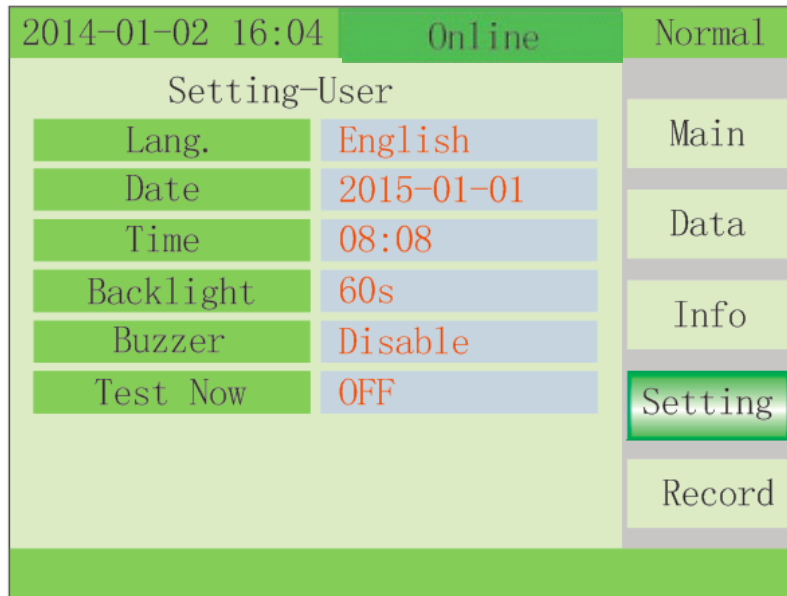

Available settings are:

Setting	Values	Default
Language:	English, Portuguese, Italian, Deutsch, Polish, Spanish, or French	English
Backlight:	On, 10 – 100s in 10s increments	ON
Buzzer:	Enable or Disable	Enable
Test Now:	OFF, 10s, 10m, EOD -End Of Discharge	OFF

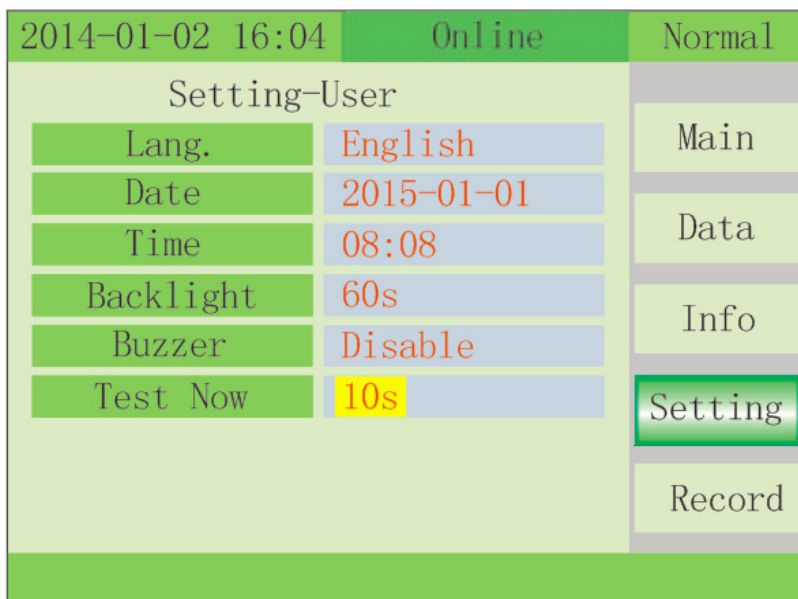

Test Now: Press ENTER key to enter test now item, press the scroll key to select test value and press ENTER to confirm. The Battery manual test command can test battery discharge for 10s, 10min and to EOD.



Maintenance : Press  + ENTER key to enter maintenance and display a password window, press  change the number and press ENTER to select the value, the password is "1121".

Record : Displays event records and fault records. Displays the Index (number in list), Time of event or fault, State (Mode) of UPS and event or fault as shown in the examples below.

Record-Event : Press the scroll key to select Up or Down or Delete. Press ENTER key to confirm.

Record-Fault : Press the scroll key to select Up or Down or Delete. Press ENTER key to confirm.

Note: If Delete is selected, all event or fault records will be deleted.

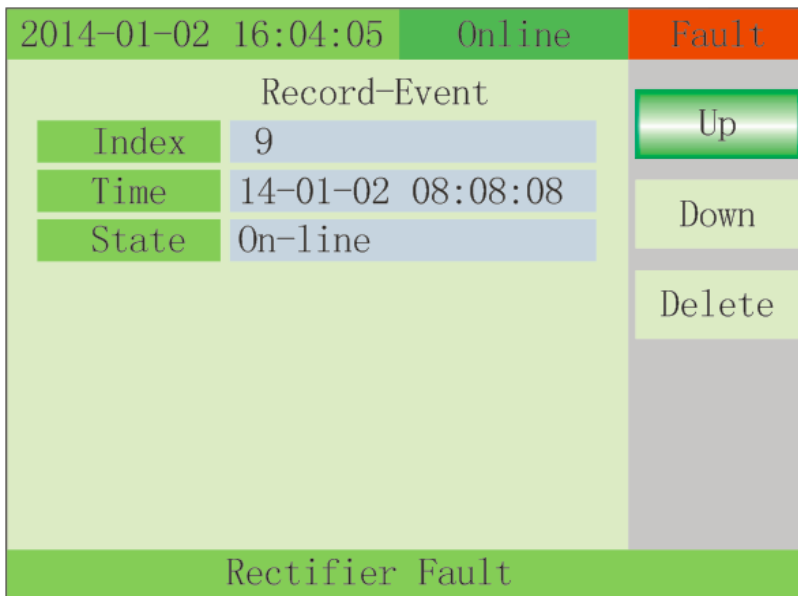
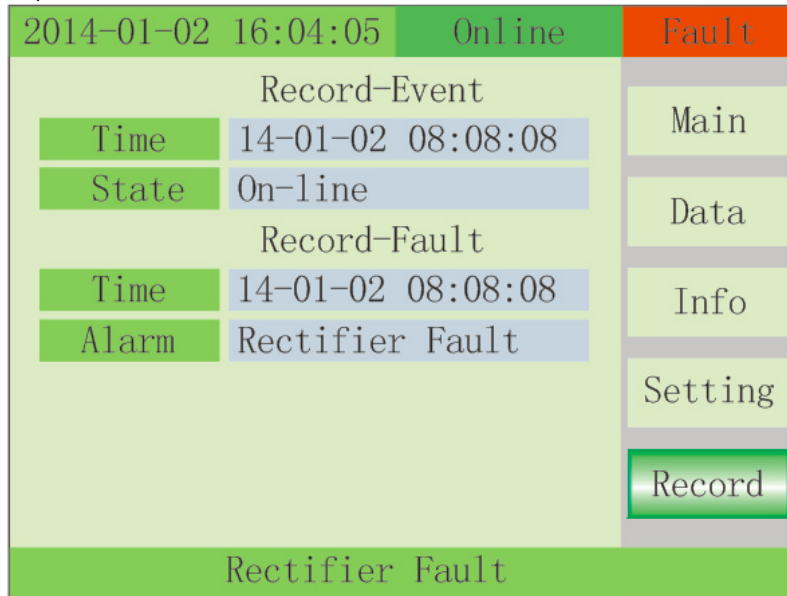

Maintenance: All system parameter setting are controlled by two keys, Scroll and Enter.

Scroll - Moves through the parameters and adjusts values

Enter – Goes into setting pages and confirms values.

To enter the Maintenance - System parameter setting mode, press the Scroll and Enter keys simultaneously for 3 seconds. The display will show a password window, press the Scroll key to change the number and press Enter to select the value, the password is "1121".

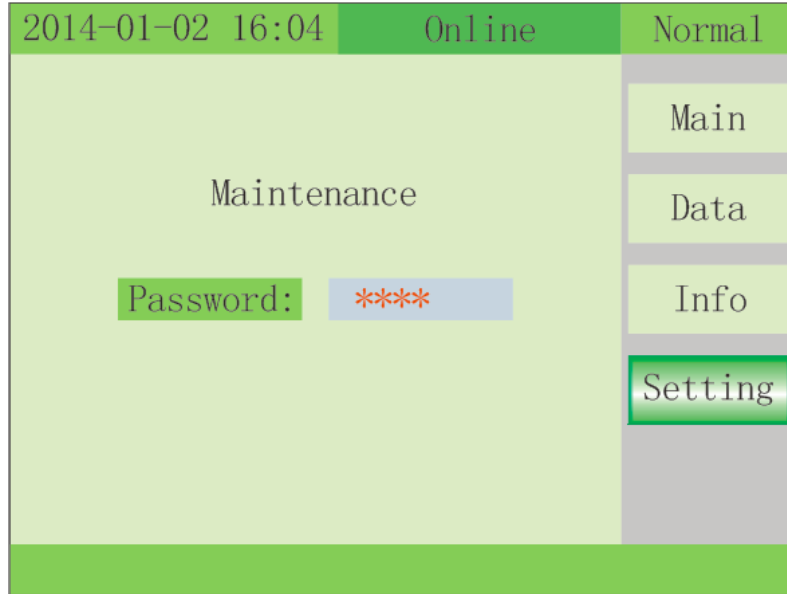

Once the Maintenance password is entered, press the Enter key. The UPS goes into the Setting-System window as shown below.

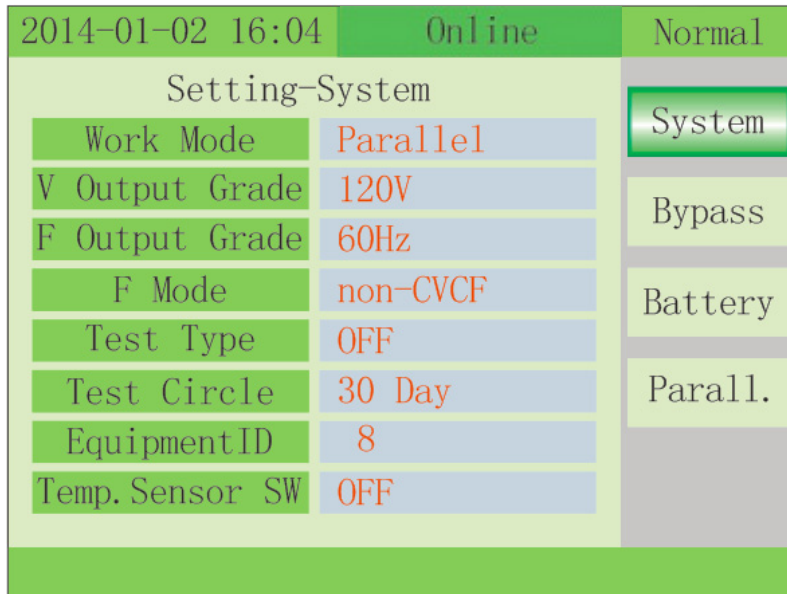

Setting-System: press the Enter key to enter item and confirm value, press the Scroll key to change the value.

The following parameters can be adjusted:

Setting-System	Range	Default
Working Mode	Normal, Parallel, ECO	ECO1
V Output Grade2	120 or 127	120
F Output Grade3	50 or 60	60
F mode	CVCF or Non-CVCF	Non-CVCF
Test type	OFF, 10s, 10min or EOD	Off
Test Cycle	1~30 days	30 days
Equipment ID4	1 - 15	1
Temp. Sensor SW	ON or OFF5	Off

1) Factory default setting for Working Mode is ECO. To disable ECO, reprogram Working Mode to Normal or Parallel.

2) Must be in static bypass to change

3) If not in static bypass, output will drop load

4) This is the MODBUS device address used for RS232 & RS485 communication ports.

a. Press Scroll key to set the address.

b. When battery temperature sensor is open, choose ID 1~10 & 13~15

c. If UPS is set for parallel mode and device address \leq parallel quantity, device address = parallel ID

d. Press "ON" to exit the device address setting and save the device address setting value and parallel ID setting.

e. Note: Under single UPS mode, until this device address setting save and exit, single UPS setting is done.

5) OFF turns off the sensor switch, ON turns on the sensor switch and send query command to sensor with address 11 and 12 every second.

Press the Scroll key to highlight Bypass and press the Enter key to enter the Setting-Bypass window as shown below.

Setting-Bypass: press the Enter key to enter item and confirm value, press the Scroll key to change the value.

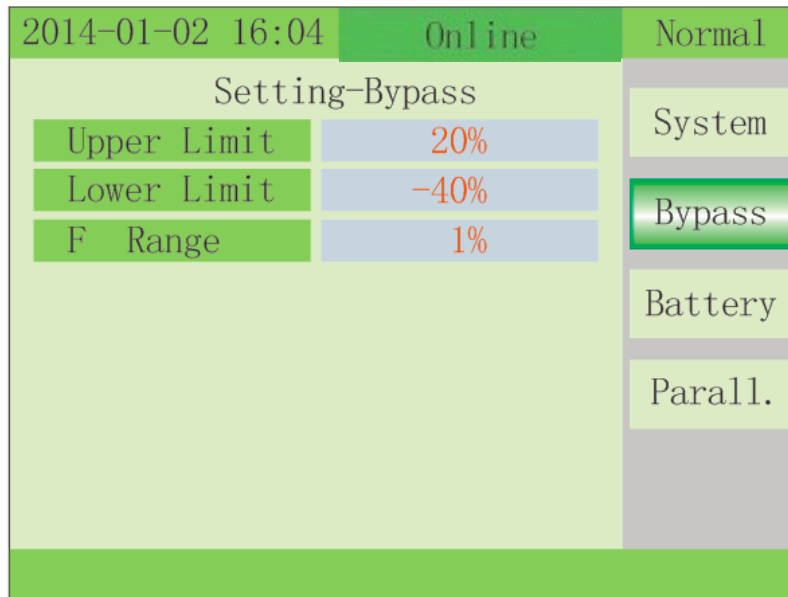

The following parameters can be adjusted:

Setting-Bypass	Range	Default
Upper Limit	10%, 15%, 20%, 25%	25% VAC
Lower Limit	-10%, -20%, -30%, -40%	-40% VAC
F_Range	1%, 2%, 4%, 5%, 10%	10% HZ

Press the Scroll key to highlight Battery and press the Enter key to enter the Setting-Battery window as shown below.

Setting-Battery: press the Enter key to enter item and confirm value, press the Scroll key to change the value.

2014-01-02 16:04	Online	Normal
Setting-Battery		
Number	20 PCS	System
Capacity	65 Ah	Bypass
Boost Charge	Enable	Battery
Group	1	Parall.
V-Boost	2.30	
V-Float	2.25	
V-EOD	1.75	
I-MaxCharge	9 A	
INV Over Temperature		

The following parameters can be adjusted:

Setting-Battery	Range	Default
Number1	20	20
Capacity2	7 - 2000	9AH
Boost Charge	Enable or disable	Enable
Group3	1-19	1
V-Boost	2.30-2.40, step is 0.01V	2.30 vpc
V-Float	2.20-2.29, step is 0.01V	2.27 vpc
V-EOD	1.60-1.90V	1.67 vpc
I-Maxcharge4	1-20A	Capacity x Group x .15

1. Number is the number of batteries per string
2. Capacity is the Amp-Hour rating of the batteries per string
3. Group is the number of strings of batteries
4. I-Maxcharge is the maximum charger current. Setting this above 15A on the E90-10kVA increases the input current rating and requires an input circuit for 45A

Press the Scroll key to highlight Parallel and press the Enter key to enter the Setting-Parallel window as shown below.

Setting-Parallel: press the Enter key to enter item and confirm value, press the Scroll key to change the value.

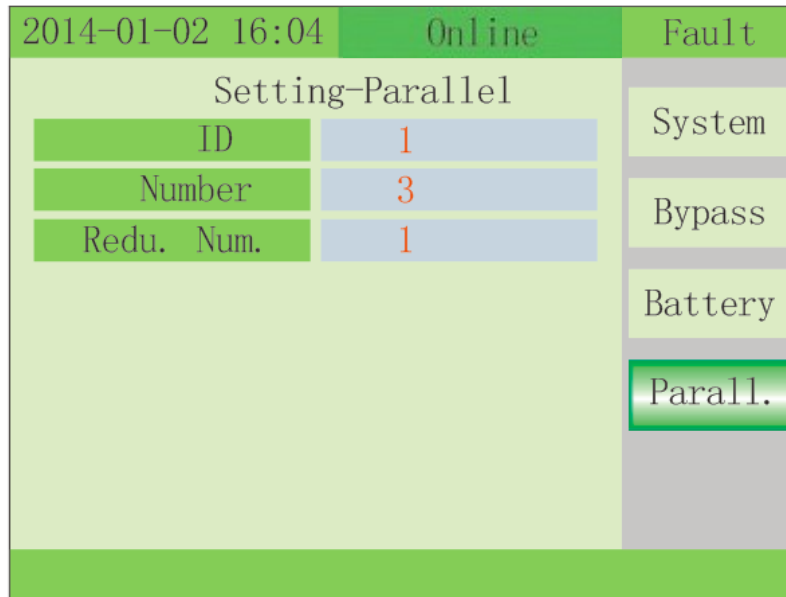

The following parameters can be adjusted:

Setting-Parallel	Range	Default
ID1	1-4	1
Number2	1-4	1
Redu. Num3	1-3	0

1. ID - Program each UPS in Parallel with a unique ID
2. Number - Program the total number of UPS systems in parallel. Maximum of 4 in parallel.
3. Redu. Num. – Program to the total number of UPS systems in parallel to be used for redundancy

The parallel system should be commissioned after all systems are operational as stand alone systems.

1. Confirm the input/output wires connection and input phase sequence are correct; switch off the battery breaker, and verify that the +/- battery voltage of all battery strings or packs are normal.
2. Connect the parallel cable, parallel cables should be installed in a loop connection.
3. Switch on the MAINS breaker of unit 1, and access LCD setting interface to set the:
 - a) Working Mode to Parallel
 - b) V Output Grade to the correct voltage
 - c) Bypass Upper and Lower Limits and F Range to default values
 - d) Battery Number to 20
 - e) Battery Capacity to the correct value for the batteries used
 - f) Battery Group to the number of battery strings
 - g) ID - Parallel ID to number 1
 - h) Parallel Number to the total number of UPS systems in parallel (1-4)
 - i) Redundant Number to the number of UPS systems to be used for redundancy
4. Turn off the MAINS breaker of Unit 1. Make sure the UPS is off. Turn on the MAINS breaker of Unit 2, access the LCD setting interface to set the:
 - a) Working Mode to Parallel
 - b) V Output Grade to the correct voltage (Same as Unit 1)
 - c) Bypass Upper and Lower Limits and F Range to default values (Same as Unit 1)
 - d) Battery Number to 20 (Same as Unit 1)
 - e) Battery Capacity to the correct value for the batteries used (Same as Unit 1)
 - f) Battery Group to the number of battery strings (Same as Unit 1)
 - g) Parallel ID to number 2
 - h) Parallel Number to the total number of UPS systems in parallel (1-4 Same as Unit 1)
 - i) Redundant Number to the number of UPS systems to be used for redundancy (Same as Unit 1)
5. For Unit 3 and Unit 4 UPS, the operation setting are all the same as Unit 1 and 2 with the exception of Parallel ID. These should be set to 3 & 4.
6. Turn on MAINS, BYPASS, and OUTPUT breakers of all the paralleled UPS systems, then confirm all the setting are correct, and each UPS has their own different ID.
7. Turn on all the battery breakers if external battery packs are installed
8. Confirm the Data-Output parameter (V/I) are normal.
9. Connect the Load, and verify that the output currents are balanced.
10. Switch on and off the utility breaker to test that all the UPS units can transfer from utility to battery and revert back to utility.

Display Messages/Troubleshooting

This section lists the event and alarm messages that the UPS might display. The messages are listed in alphabetical order. This section is listed with each alarm message to help you troubleshoot problems.

Operational Status and Model(s)

Code (ST)	Information stand for	LED			
		Fault	Bypass	Battery	Inverter
1	Initialized	EXTINGUISH	EXTINGUISH	EXTINGUISH	EXTINGUISH
2	Standby Mode	EXTINGUISH	EXTINGUISH	X	EXTINGUISH
3	No Output	EXTINGUISH	EXTINGUISH	X	EXTINGUISH
4	Bypass Mode	EXTINGUISH	LIGHT	X	EXTINGUISH
5	Utility Mode	EXTINGUISH	EXTINGUISH	X	LIGHT
6	Battery Mode	EXTINGUISH	EXTINGUISH	LIGHT	EXTINGUISH
7	Battery Self-diagnostics	EXTINGUISH	EXTINGUISH	LIGHT	EXTINGUISH
8	Inverter is starting up	EXTINGUISH	X	X	EXTINGUISH
9	ECO Mode	EXTINGUISH	X	X	X
10	EPO Mode	LIGHT	EXTINGUISH	X	EXTINGUISH
11	Maintenance Bypass Mode	EXTINGUISH	EXTINGUISH	EXTINGUISH	EXTINGUISH
12	Fault Mode	LIGHT	X	X	X

CAUTION:"X" means it is determined by other conditions

Alarm Information

Fault code (Err)	UPS Alarm Warning	Buzzer	LED
1	Rectifier Fault	Beep continuously	Fault LED lit
2	Inverter fault(Including Inverter bridge is shorted)	Beep continuously	Fault LED lit
3	Inverter Thyristor short	Beep continuously	Fault LED lit
4	Inverter Thyristor broken	Beep continuously	Fault LED lit
5	Bypass Thyristor short	Beep continuously	Fault LED lit
6	Bypass Thyristor broken	Beep continuously	Fault LED lit
7	Fuse broken	Beep continuously	Fault LED lit
8	Parallel relay fault	Beep continuously	Fault LED lit
9	Fan fault	Beep continuously	Fault LED lit
10	Reserve	Beep continuously	Fault LED lit
11	Auxiliary power fault	Beep continuously	Fault LED lit
12	Initialization fault	Beep continuously	Fault LED lit
13	P-Battery Charger fault	Beep continuously	Fault LED lit
14	N-Battery Charger fault	Beep continuously	Fault LED lit
15	DC Bus over voltage	Beep continuously	Fault LED lit
16	DC Bus below voltage	Beep continuously	Fault LED lit
17	DC bus unbalance	Beep continuously	Fault LED lit
18	Soft start failed	Beep continuously	Fault LED lit

19	Rectifier Over Temperature	Twice per second	Fault LED lit
20	Inverter Over temperature	Twice per second	Fault LED lit
21	Input neutral loss	Twice per second	Fault LED lit
22	Battery reverse	Twice per second	Fault LED lit
23	Cable connection error	Twice per second	Fault LED lit
24	CAN comm. Fault	Twice per second	Fault LED lit
25	Parallel load sharing fault	Twice per second	Fault LED lit
26	Battery over voltage	Once per second	Fault LED blinking
27	Mains Site Wiring Fault	Once per second	Fault LED blinking
28	Bypass Site Wiring Fault	Once per second	Fault LED blinking
29	Output Short-circuit	Once per second	Fault LED blinking
30	Rectifier over current	Once per second	Fault LED blinking
31	Bypass over current	Once per second	BPS LED blinking
32	Overload	Once per second	INV or BPS LED blinking
33	No battery	Once per second	Battery LED blinking
34	Battery under voltage	Once per second	Battery LED blinking
35	Battery low pre-warning	Once per second	Battery LED blinking
36	Internal Communication Error	Once per 2 seconds	Fault LED blinking
37	DC component over limit.	Once per 2 seconds	INV LED blinking
38	Parallel Overload	Once per 2 seconds	INV LED blinking
39	Mains volt. Abnormal	Once per 2 seconds	Battery LED lit
40	Mains freq. abnormal	Once per 2 seconds	Battery LED lit
41	Bypass Not Available		BPS LED blinking
42	Bypass unable to trace		BPS LED blinking
43	Inverter on invalid		
44	Reserve		
45	inverter not on		
46	Output switch not ON	Once per 3 seconds	

Options

SNMP card: internal SNMP / external SNMP optional

- Loosen the 2 torque screws (on each side of the card).
- Carefully pull out the card. Reverse the procedure for re-installation

The slot called SNMP supports the MEGAtec protocol. We advise that NetAgent II-3 port is also a tool to remotely monitor and manage any UPS system

NetAgent II-3Ports supports the Modem Dial-in (PPP) function to enable the remote control via the internet when the network is unavailable.

NetAgent II has the option to add NetFeeler Lite to detect temperature, humidity, smoke and security sensors. Thus, making NetAgent II a versatile management tool. NetAgent II also supports multiple languages and is setup for web-based auto language detection.

Problems and Solution

In case the UPS cannot work normally, it might be improper installation, wiring or operation. Please check these aspects first. If all these aspects are checked without any problem, please consult with local agent right away and provide below information.

(1) Product model name and serial number.

(2) Try to describe the fault with more details, such as LCD display info, LED lights status, etc.

Read the user manual carefully, it can help a lot for using this UPS in the right way. Some FAQ (frequently asked questions) may help you to troubleshoot your problem easily.

No.	Problem	Possible reason	Solution
1	Utility is connected but the UPS cannot be powered ON.	Input power supply is not connected; Input voltage low; The input switch of the UPS is not switched on.	Measure if the UPS input voltage/frequency is within the window. Check if UPS input is switched on
2	Utility normal but Utility LED does not light on, and the UPS operates at battery mode	The input breakers of the UPS are not switched on; input cable is properly connected.	Switch on the input breaker; Make sure the input cable is properly connected.
3	The UPS does not indicate any failure, but output does not have voltage	Output cable is not properly connected; Output breaker is not switched on.	Make sure the output cable is properly connected; Switch on the output breaker.
4	Utility LED is flashing	Utility voltage exceeds UPS input range.	If the UPS operates at battery mode, please pay attention to the remaining backup time needed for your system.
5	Battery LED is flashing but no charge voltage and current	Battery breaker does not switch on, or batteries are damaged, or battery is reversely connected. Battery number and capacity are not set correctly.	Switch on the battery breaker. If batteries are damaged, need to replace whole group batteries, Connect the battery cables correctly; Go to LCD setting of the battery number and capacity, set the correct data.
6	Buzzer beeps every 0.5 seconds and LCD display "output overload"	Overload	Remove some load
7	Buzzer long beeps, LCD display "29" fault code	The UPS output is in short circuit	Make sure the load is not in short circuit, and then restart the UPS.
8	The UPS only works on bypass mode	The UPS is set to ECO mode	Set the UPS working mode to normal mode or re-start the UPS. Note: UPS is set to ECO as default
9	Cannot cold start	Battery switch is not properly closed: Battery fuse is open: Or Battery low: Battery quantity set wrong; Power breaker in the rear panel not switch ON.	Close the battery switch: Change the fuse: Recharge the battery: Power ON the UPS with AC to set the battery quantity & quantity; Switch on the power breaker.

No.	Problem	Possible reason	Solution
10	Buzzer beeps continuously and LCD indicates 1,3,5,9,15, etc fault codes	UPS is out of order	Consult with your local agent for repair

Display Messages/Troubleshooting

This section lists the event and alarm messages that the UPS might display. The messages are listed in alphabetical order. This section is listed with each alarm message to help you troubleshoot problems.

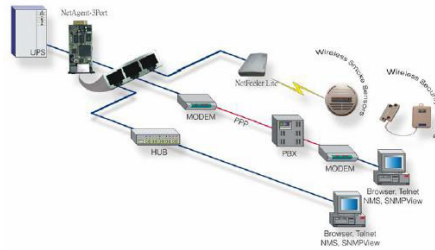

Typical topology of the UPS Network Management

Relay card

The relay card contains six dry contact outputs and one dry input. The inputs and outputs are factory programmed according to functions listed in the table

The 10-pin terminal on the relay card allows the signal for Bypass, Mains abnormal, Inverter On, Battery Low, UPS fault, and UPS Alarm to be connected to external lights or devices and the UPS to be shutdown remotely.

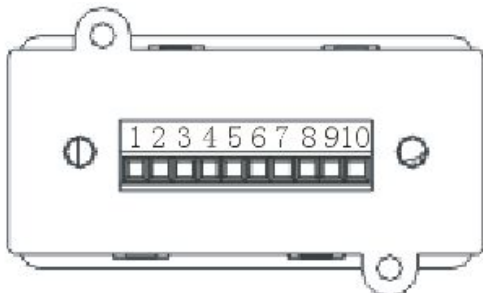

Port		Function
1	Output	Mains abnormal
2		Battery Low
3		Battery Low
4		On Bypass
5		UPS Fault
6		Inverter On
7		UPS Alarm
8	COM	
9	Input (5~12V)	Remote Shutdown +
10		Remote Shutdown -

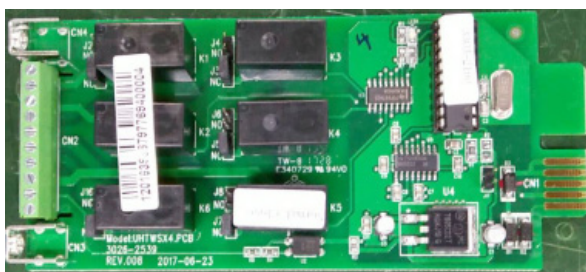

USB communication port definition

Definition of port:

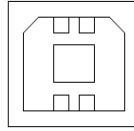

Connection between PC USB port and UPS USB port.

PC USB port	UPS USB port	Description
Pin 1	Pin 1	PC : +5V
Pin 2	Pin 2	PC : DPLUS signal
Pin 3	Pin 3	PC : DMINUS signal
Pin 4	Pin 4	Signal ground

Available function of USB

- Monitor UPS power status.
- Monitor UPS alarm info.
- Monitor UPS running parameters.
- Timing off/on setting.

Communication data format

Baud rate ----- 9600bps

Byte length ----- 8bit

End bit ----- 1bit

Parity check -----none



CAUTION!

USB, RS232 and RS485 interface cannot be used at the same time, you can only use one of them at one time.

RS232 communication port definition

Definition of Male port:

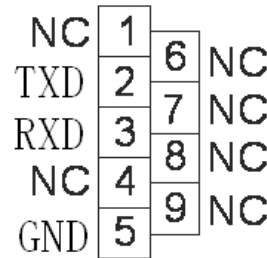

Connection between PC RS232 port and UPS RS232 port

PC RS232 port	UPS RS232 port	
Pin 2	Pin 2	UPS send,PC receive
Pin 3	Pin 3	PC send,UPS receive
Pin 5	Pin 5	ground

Available function of RS232

- Monitor UPS power status.
- Monitor UPS alarm info.
- Monitor UPS running parameters.
- Timing off/on setting.

RS-232 communication data format

Baud rate ----- 9600bps

Byte length ----- 8bit

End bit ----- 1bit

Parity check -----none



CAUTION!

USB, RS232 and RS485 interface cannot be used at the same time, you can only use one of them at one time.

RS485 communication port definition

Definition of port:

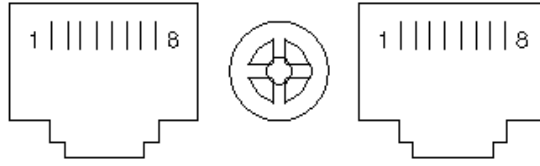

Connection between the Device's RS485 port and UPS RS485 port.

device(RJ45)	UPS(RJ45)	Description
Pin 1/5	Pin 1/5	485+ "A"
Pin 2/4	Pin 2/4	485 - "B"
Pin7	Pin7	+12Vdc
Pin8	Pin8	GND

Available function of RS485

- Monitor UPS power status.
- Monitor UPS alarm info.
- Monitor UPS running parameters.
- Timing off/on setting.
- Battery environment temperature monitoring.
- Charging voltage modulation depending on batteries temperature

Communication data format

Baud rate ----- 9600bps

Byte length ----- 8bit

End bit ----- 1bit

Parity check -----none



CAUTION!

USB, RS232 and RS485 interface cannot be used at the same time, you can only use one of them at one time.

RS485 port pin7 is 12Vdc!

BAT_T communication port definition

BAT_T communication ports are the same as the RS485 communication ports. The UPS automatically senses the temperature probes when installed into the RS485 communication ports.

Definition of port:

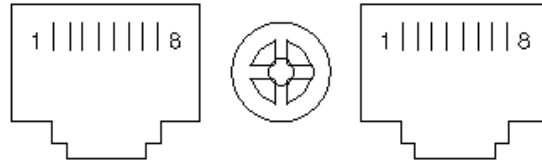

Connection between the Temperature sensor RJ45 port and UPS RJ45 port.

Temperature sensor(RJ45)	UPS BAT_T (RJ45)	Description
Pin 1/5	Pin 1/5	TX
Pin 2/4	Pin 2/4	RX
Pin 7	Pin 7	12V
Pin 8	Pin 8	GND

Available function of BAT_T

- Battery environment temperature monitoring.
- Charging voltage modulation depending on batteries' temperature.

Optional dry contact output definition

Definition of Male port:

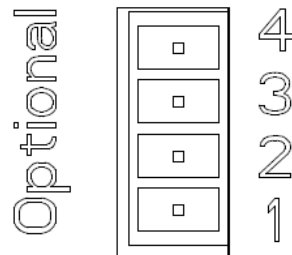

Instruction:

UPS	Instruction
Pin1	Normally NC
Pin2	Normally NO
Pin3	NC
Pin4	Common

- Function 1 description (default):
- This signal is activated when the UPS initiates backfeed protection and can be wired to open the external input breaker
- Function 1 is selected by placing the jumper on J6
- Function 2 description (requires jumper setting change inside the UPS):
- This signal is activated 1 minute after the UPS reaches EOD and can be wired to open the DC breaker of external battery.
- Function 6 is selected by placing the jumper on J5

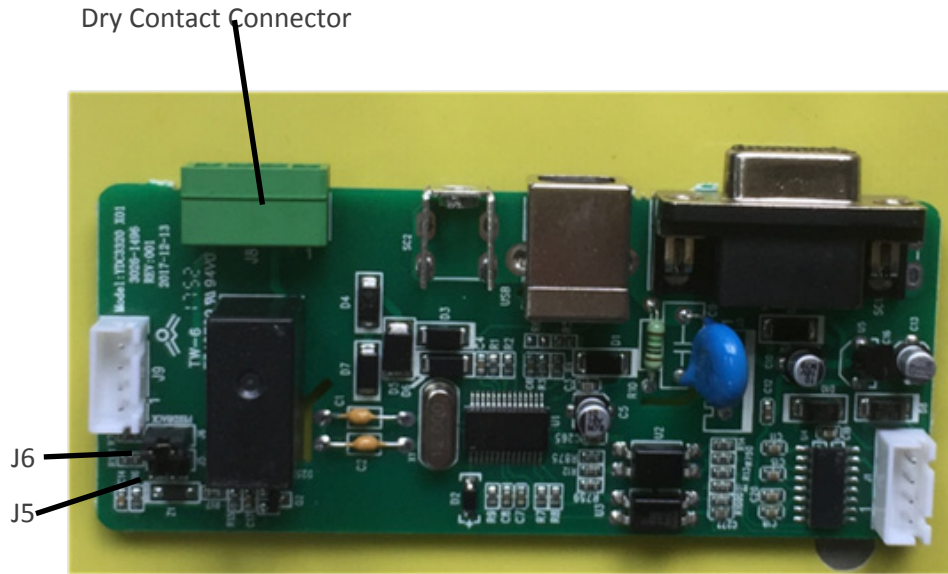

REPO instruction

Definition of port:

Connection diagram:

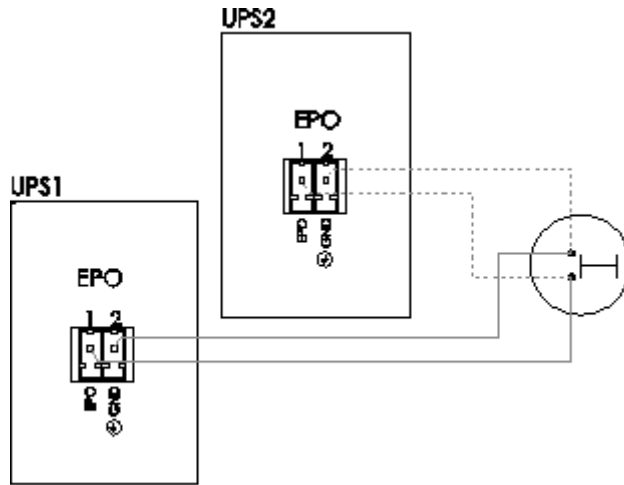

Connection between the button and UPS REPO port.

Button	UPS REPO	Description
Pin 1	Pin 1	EPO
Pin 2	Pin 2	GND

- A remote emergency stop switch (EPO) can be installed in a remote location and connected to the REPO connector.
 - o Requires normally open dry contact signal
- The remote switch can be connected to several UPS in a parallel architecture allowing the user to stop all units at once.

Specifications

MODEL NUMBER		E90-10K	E90-15K	E90-20K
CAPACITY	Power rating	10kVA/10kW	15kVA/15kW	20kVA/20kW
INPUT	Voltage / Range	208Y/120VAC or 220Y/127VAC / 125-275VAC three-phase*		
	Frequency	40–70Hz auto-sensing		
OUTPUT	Voltage / Regulation	208/120VAC or 220/127VAC / $\pm 1\%$ three-phase		
	Frequency	50/60 \pm 0.1%		
	Overload capacity	150% for 1 min, 125% for 10 min, 110% for 60 min		
	Efficiency	Up to 94% online mode or 98% ECO mode		
BATTERY	Battery Type	Sealed maintenance-lead acid		
	Battery quantity	Up to (60) 12V 9AH		
	Charger Voltage / Current	273VDC / 1A-20A (max) programmable from LCD		
PHYSICAL	Dimensions (W x D x H)	9.8 x 39.2 x 34.0 in		
	Input / Output	Terminal blocks		
	Weight	296 lbs (1 string)	419 lbs (2 string)	539 lbs (3 string)
OPTIONAL BATTERY PACK	Model	EBP80-63A	EBP80-125A	
	Battery quantity and size	(80) 12V 9AH		
	Dimensions (W x D x H)	9.8 x 39.2 x 34.0 in		
	Weight	535 lbs		
ENVIRONMENT	Operating temperature	32–104°F (0–40°C)		
	Audible noise	<55dB from 1M distance for 10/15kVA; <58dB from 1M distance for 20kVA		
	Altitude	5,200 ft above sea level**		
APPROVALS	UL, FCC, RoHS			
WARRANTY	2 years electronics, 2 years battery warranty (USA and Canada)			
COMMUNICATIONS INTERFACE	RS-232, EPO, RS485, USB, dry contact, (2) slots for optional cards (Web/SNMP, Relay/dry contact)			
INCLUDED IN BOX	User manual, RS-232 communication cable, USB cable, Muser monitoring software			
AVAILABLE OPTIONS	External maintenance bypass, output distribution, external battery packs, parallel cables			

*Depending on load level. **Battery life is reduced above 30°C, UPS capacity derates above 40°C and 5,200 ft above sea level

Internal Battery Replacement

The internal batteries may be configured as 20, 40 or 60 pieces of 12V 9AH batteries. The batteries are configured using 20 batteries in each string, with a center-tap (Neutral). The DC bus is +/- 120VDC. One string of batteries is on the left side of the UPS and two strings are on the right side.

1. Place the protected loads on Maintenance Bypass and turn off the UPS.
2. Remove the right, left and top panels of the UPS. Remove the right and left cover plates over the batteries to remove and install the batteries.

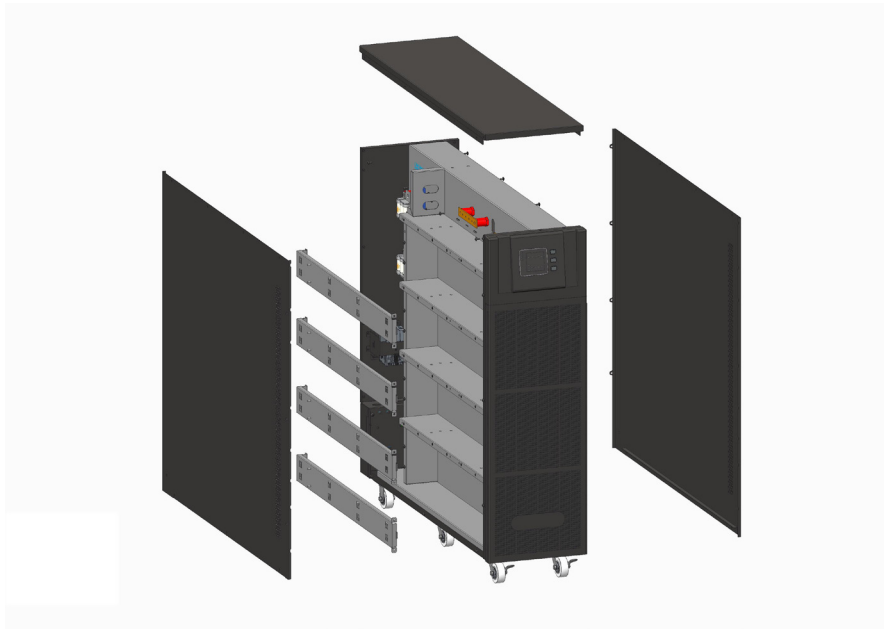

3. Battery replacement and connection

Disconnect the most positive and most negative wires from the 10 batteries on a shelf. The wire end should be insulated to prevent arcing. Remove the inter-connecting jumpers between all 10 batteries. Remove and replace the batteries. Reconnect all jumpers between the batteries ensuring all connections are tight. Reconnect the most positive wire and the most negative wire ensuring both connections are tight.

Repeat the process above on all shelves containing batteries until all of the batteries have been replaced.

4. Reinstall the cover plates over the batteries and the right, left, and top panels of the UPS.
5. Restart the UPS and transfer the protected loads back to the UPS via the Maintenance Bypass

UPS internal battery configuration

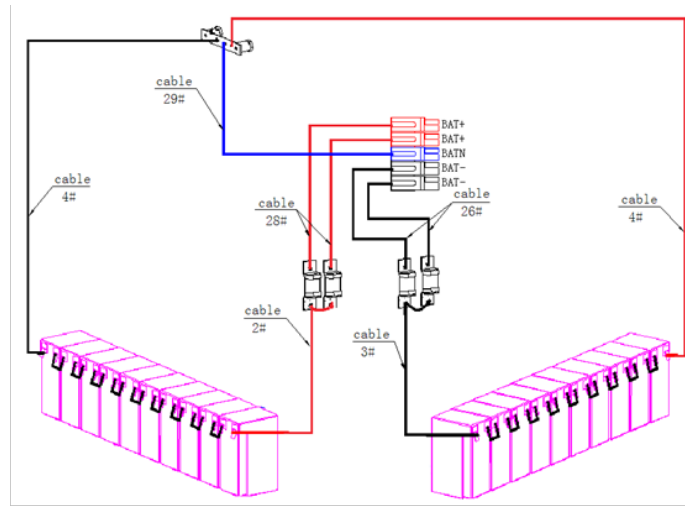

Wiring diagram for 20pcs of batteries installation

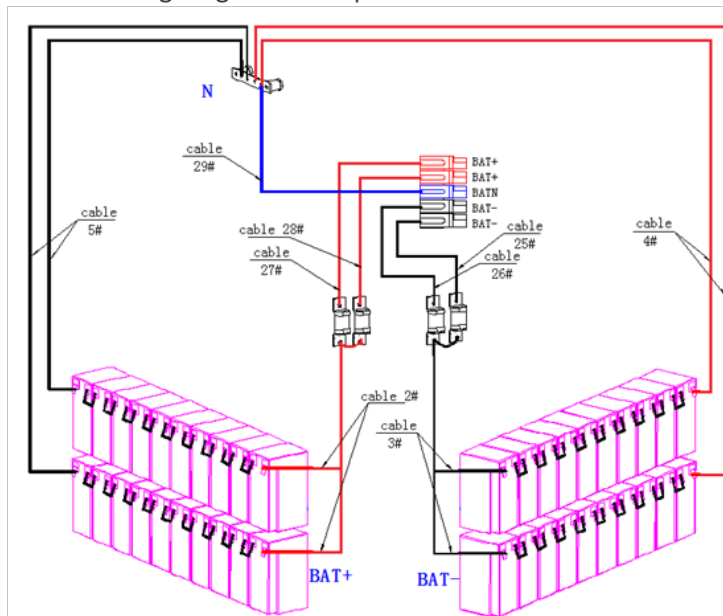

Wiring diagram for 40pcs of batteries installation

UPS internal battery configuration

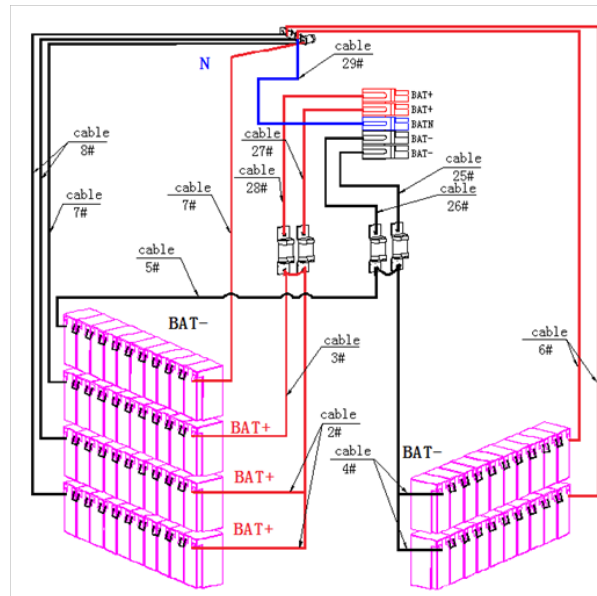

Wiring diagram for 60pcs of batteries installation

Note: A complete string of batteries are configured using 20 batteries with a center-tap (Neutral) in each string. The DC bus is +/- 120VDC. One string of batteries is on the left side of the UPS and two strings are on the right side.

EBP80-63A and EBP80-125A Battery Replacement

The EBP80-63A and EBP80-125A matching battery packs will be configured as 80 pieces of 12V 9AH batteries. The batteries are configured using 20 batteries in each string, with a center-tap (Neutral). The DC bus is +/- 120VDC. Two strings of batteries are on the left side of the cabinet and two strings are on the right side. Up to four external battery packs may be connected to achieve longer runtime.

1. Turn off the DC breaker on the back of the battery pack prior to changing the batteries. If multiple cabinets are connected, the remaining battery packs will continue to support the UPS.
2. Remove the right and left cover plate of the battery pack to remove and install the batteries.



3. Battery replacement and connection

Disconnect the most positive and most negative wires from the 10 batteries on a shelf. The wire end should be insulated to prevent arcing. Remove the inter-connecting jumpers between all 10 batteries. Remove and replace the batteries. Reconnect all jumpers between the batteries ensuring all connections are tight. Reconnect the most positive wire and the most negative wire ensuring both connections are tight.

Repeat the process above on all shelves containing batteries until all of the batteries have been replaced.

4. Reinstall the cover plates over the batteries and the right, left, and top panels of the battery pack.

5. Turn on the DC breaker.

6. Repeat the process above on all shelves containing batteries until all of the batteries have been replaced.

7. When the battery replacement and connection are completed, use a multi-meter or other instrument to check if the voltages between BAT+ and N, N and BAT- are normal. If normal, reinstall the chassis panels.

Note: The positive and negative of battery should not be reversed or short circuited, or it will damage the battery, UPS, or cause injury. Do not touch the battery positive and negative at the same time. Before replacing or removing the batteries, please disconnect the breaker, disconnect cell terminals and remove the screws of the copper bar.

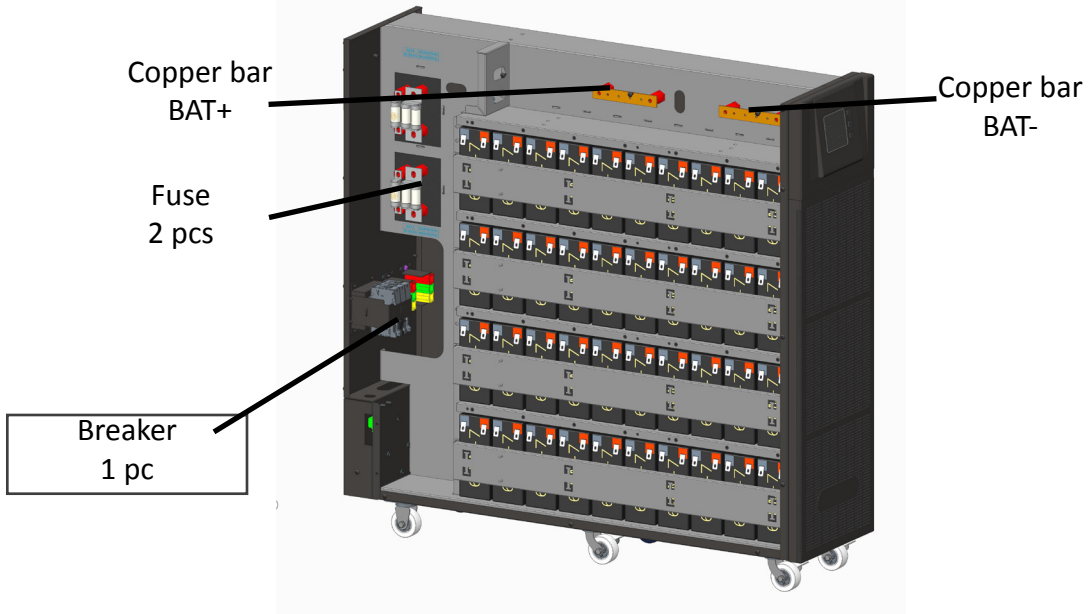

EBP80 Left side View

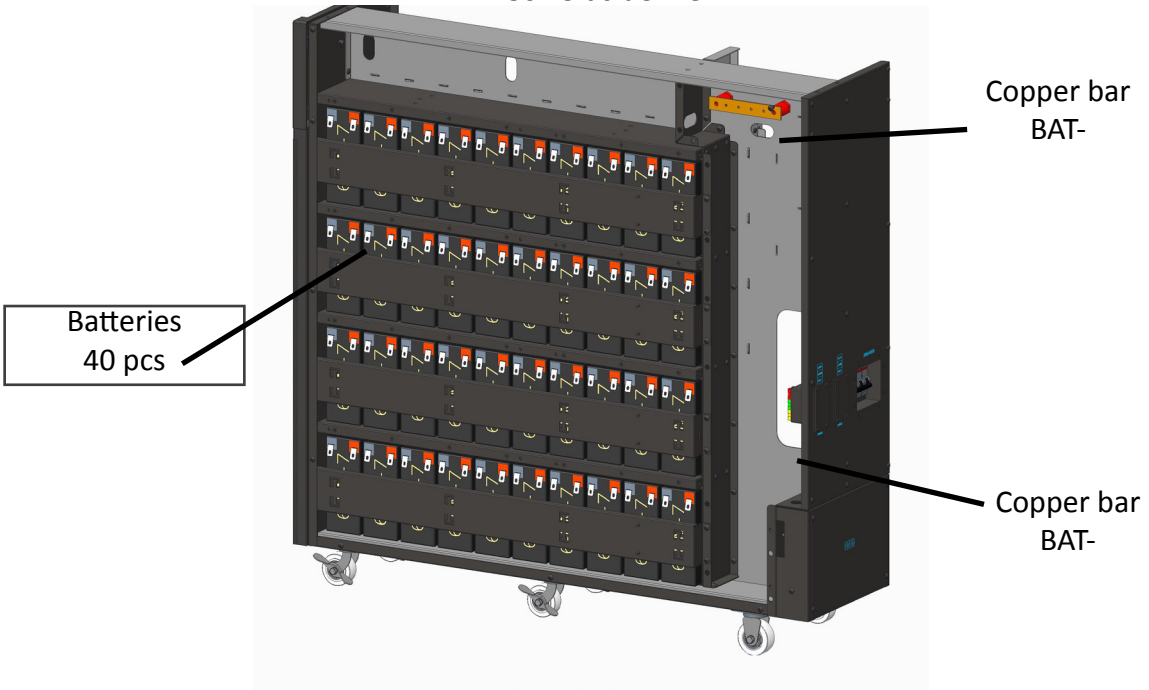

EBP80 Right Side View

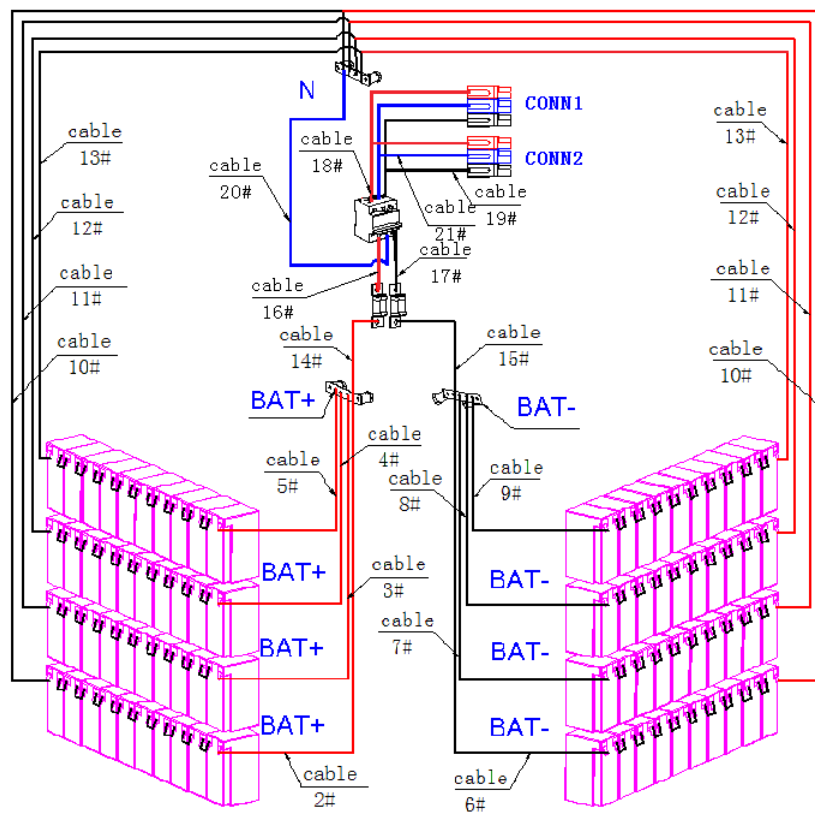

Wiring diagram for 80pcs of batteries installation

Obtaining Service

If the UPS requires Service:

1. Use the TROUBLESHOOTING section in this manual to eliminate obvious causes.
2. Verify there are no circuit breakers tripped.
3. Call your dealer for assistance. If you cannot reach your dealer, or if they cannot resolve the problem, call Xtreme Power Conversion Corp Technical Support at 800.582.4524. Technical support inquiries can also be made at support@xpcc.com. Please have the following information available BEFORE calling the Technical Support Department:
 - Your name and address.
 - The serial number of the unit.
 - Where and when the unit was purchased.
 - All of the model information about your UPS.
 - Any information on the failure, including LED's that may or may not be illuminated.
 - A description of the protected equipment, including model numbers if possible.
 - A technician will ask you for the above information and, if possible, help solve your problem over the phone. In the event that the unit requires factory service, the technician will issue you a Return Material Authorization number (RMA).

If you are returning the UPS to Xtreme Power for service, please follow these procedures:

1. Pack the UPS in its original packaging. If the original packaging is no longer available, ask the Technical Support Technician about obtaining a replacement set of packaging material. It is important to pack the UPS properly in order to avoid damage in transit. Never use Styrofoam beads for a packing material.
2. Include a letter with your name, address, daytime phone number, RMA number, a copy of your original sales receipt, and a brief description of the problem.
3. Mark the RMA number on the outside of all packages. Xtreme Power cannot accept any package without the RMA number marked on the outside of the boxes.
4. Return the UPS by insured, prepaid carrier to the address provided by the Technician.
5. Refer to the Warranty statements in this manual for additional details on what is covered.

Xtreme Power Conversion Limited Warranty

Xtreme Power Conversion (XPC) Corporation warrants Xtreme Power Conversion equipment, when properly applied and operated within specified conditions, against faulty materials or workmanship for a period of **two years for E90-Series products** from the date of purchase. XPC Corporation warrants **internal batteries for a period of two years** from the date of purchase. For equipment sites within the United States and Canada, this warranty covers repair or replacement, at the sole discretion of XPC Corporation. The customer is responsible for the costs of shipping the defective product to XPC Corporation. XPC Corporation will pay for ground shipment of the repaired or replacement product. This warranty applies only to the original purchaser.

If equipment provided by XPC Corporation is found to be **Dead-on-Arrival (DOA)**, XPC Corporation will be responsible for the costs of shipping product to and returning equipment from the customer in a timely manner as agreed to with the customer, once the customer has requested and received a **Return Material Authorization (RMA)** number. DOA equipment is defined as equipment that does not properly function according to user documentation when initially received and connected in conjunction with proper procedures as shown in the user documentation or via support provided by XPC Corporation personnel or authorized agents.

This warranty shall be void if (a) the equipment is repaired or modified by anyone other than XPC Corporation or a XPC Corporation approved third party; (b) the equipment is damaged by the customer, is improperly used or stored, is subjected to an adverse operating environment, or is operated outside the limits of its electrical specifications; or (c) the equipment has been used or stored in a manner contrary to the equipment's operating manual, intended use or other written instructions. Any technical advice furnished by XPC Corporation or a XPC Corporation authorized representative before or after delivery with regard to the use or application of Xtreme Power Conversion equipment is furnished on the basis that it represents XPC Corporations best judgment under the situation and circumstances, but it is used at the recipient's sole risk.

EXCEPT AS STATED ABOVE, XPC Corporation DISCLAIMS ALL WARRANTIES, EXPRESSED OR IMPLIED, INCLUDING WARRANTIES OF MERCHANTABILITY AND FITNESS FOR A PARTICULAR PURPOSE.

EXCEPT AS STATED ABOVE, IN NO EVENT WILL XPC Corporation BE LIABLE FOR DIRECT, INDIRECT, SPECIAL, INCIDENTAL, OR CONSEQUENTIAL DAMAGES ARISING OUT OF THE USE OF Xtreme Power Conversion EQUIPMENT, including but not limited to, any costs, lost profits or revenue, loss of equipment, loss of use of equipment, loss of software, loss of data, cost of substitutes, or claims by third parties. Purchaser's sole and exclusive remedy for breach of any warranty, expressed or implied, concerning Xtreme Power Conversion equipment, and the only obligation of XPC Corporation under this warranty, shall be the repair or replacement of defective equipment, components, or parts; or, at XPC Corporations sole discretion, refund of the purchase price or substitution of an equivalent replacement product.

XPC Corporation
230 Yuma Street
Denver, CO 80223
1.800.582.4524