



# **Long Runtime Solutions for Uninterruptible Power Systems**

February 2011

## Introduction:

Battery backup time in single phase Uninterruptible Power Supply (UPS) applications is considered one of the most important factors in sizing a UPS. Runtime estimations commonly consist of comparing the critical load Volt Amps (VA) or Watts (W) to the corresponding UPS rating to determine a nominal runtime for the given load. Although this is “common practice” in sizing many UPS applications, it is not an absolute indicator when determining the application’s runtime requirements. Other factors such as site power distribution along with variable load, and site requirements need to be considered to accurately determine the application runtime requirement.

When factoring the onsite power distribution network into runtime requirements, the use of a generator is a key component to consider. For example, if the site has a generator connected to the critical load distribution feeding the UPS, then the runtime requirement *may be* minimized since the generator will begin supplying input power to the UPS shortly after a utility failure occurs. For sites without a generator, the heat load of critical equipment must be taken into consideration for long runtime applications to prevent equipment overheating without the presence of air conditioning while on battery power.

Load and site backup requirements will vary, but in all cases the runtime requirement should factor in any future loads to continually adhere to the determined runtime requirement. In applications where future loads are not considered, the UPS or batteries may need to be replaced to accommodate new loads if the battery system cannot be expanded to meet the same runtime requirement. Certain industry requirements may mandate specific UPS run times which may not be met when future loads are added.

Thorough examination of all the application run time requirement factors such as the examples mentioned above often reveals that the application requires more runtime than the “common practice” may indicate. This white paper will describe the single phase UPS design considerations necessary for longer runtime applications while outlining the key benefits of UPS systems designed specifically for these applications.

## The Problem

Historically, manufacturers have struggled to provide workable solutions in single phase applications requiring more than two hours of holdover time. Although many UPS’ offer optional extended battery backs to increase run time, the UPS’ are often limited in the number of battery packs that can be added to the system. In most cases the optional battery packs are charged from the UPS internal charger. The number of battery packs is limited to the size of

the UPS internal charger subsequently limiting the runtime of the system. (see Figure 1) Therefore, it is common to see UPS systems in the marketplace only support up to 2, 3, or 4 battery packs.

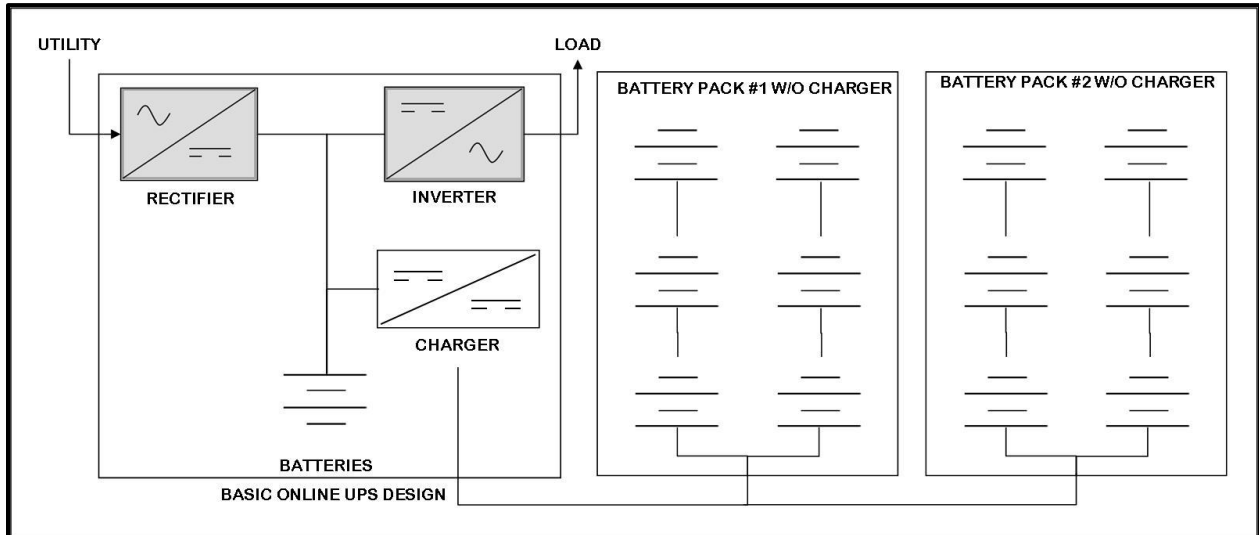

Figure 1

In these systems, where the UPS internal charger is the only charger for the extended battery packs, the recharge time can exceed 30 hours or more. This can also dramatically decrease runtime should there be multiple power losses in a short period of time.

It has been a common, although undesirable practice to overcome this runtime limitation by over sizing the UPS for the given load in order to meet the runtime requirement. Although this may allow the runtime requirement to be met, this often leads to increased upfront equipment costs while inhibiting future system growth to meet the same runtime requirement.

## The Solution

Integrating battery chargers into the UPS optional battery pack design (see Figure 2) solves long runtime requirements and alleviates any recharge time concerns. In this solution the manufacturer's battery pack chargers are paralleled together with the UPS charger for a higher capacity, thus enabling the needed runtimes in almost every application. The paralleled battery pack chargers also provide the matched UPS charging algorithm allowing for a balanced and efficient recharge process in a fraction of the time of the UPS charger alone. Batteries are typically recharged to 90% capacity within only 4 hours of AC power returning to the system.

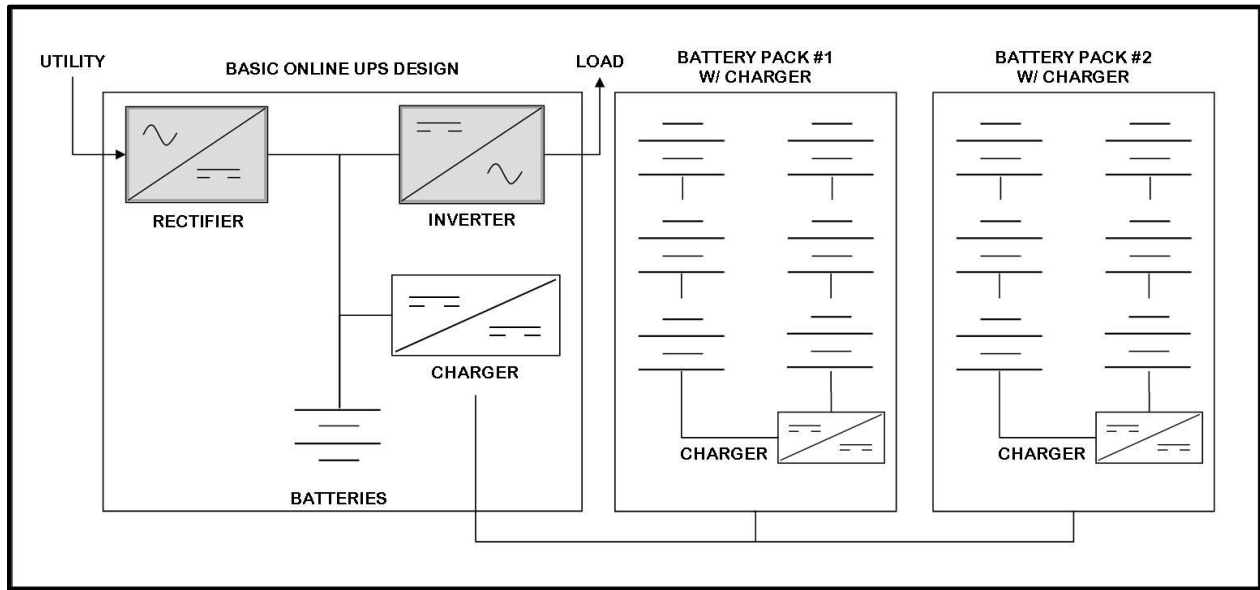

Figure 2

## Xtreme Advantage:

Few UPS manufacturers have incorporated this solution of additional battery pack chargers into their standard product design. Of the available long runtime product solutions in the marketplace today, there are key product features that need to be considered when sourcing a solution. Solutions such as Xtreme Power Conversion Corporation's (XPC) Network Xtreme Rack Tower UPS (NXRT) not only solve the long runtime requirements and recharge concerns, but also add the following key features to the system:

- **External AC Charging-** Each NXRT optional battery pack contains its own charger circuit board that can be connected to an external AC source decreasing charging time.
- **Exceeds 24 Hours of Backup Time-** Almost any application's runtime requirement can be met with the NXRT's 3 stage, charging algorithm coupled with a paralleled charger structure
- **Simple Installation-** Battery packs are daisy chained together with no programming needed by the end user.
- **Hot Swappable Battery Trays-** Battery strings in the UPS and optional battery packs can be replaced without taking the system offline.
- **Optional SNMP Card-** SNMP card is available to monitor estimated battery runtime remaining and other battery parameters.
- **Multiform Factor-** The battery pack matches the NXRT's form factor allowing it to be mounted in a 4 or 2 post rack, on the wall, or in the tower position

## How the NXRT works to achieve long runtimes:

The first Extended Battery Pack (EBP) on the NXRT UPS is connected by an external battery connection. The second EBP will connect to the first EBP and so on (*see Figure 3*) until all battery packs are connected to meet the application runtime requirement. The NXRT battery packs are paralleled to each other by means of a parallel/series cable connection. This parallel architecture maintains the nominal DC voltage constant between battery packs while allowing the charger current to be summed together for a higher output. (*see Figure 4*)

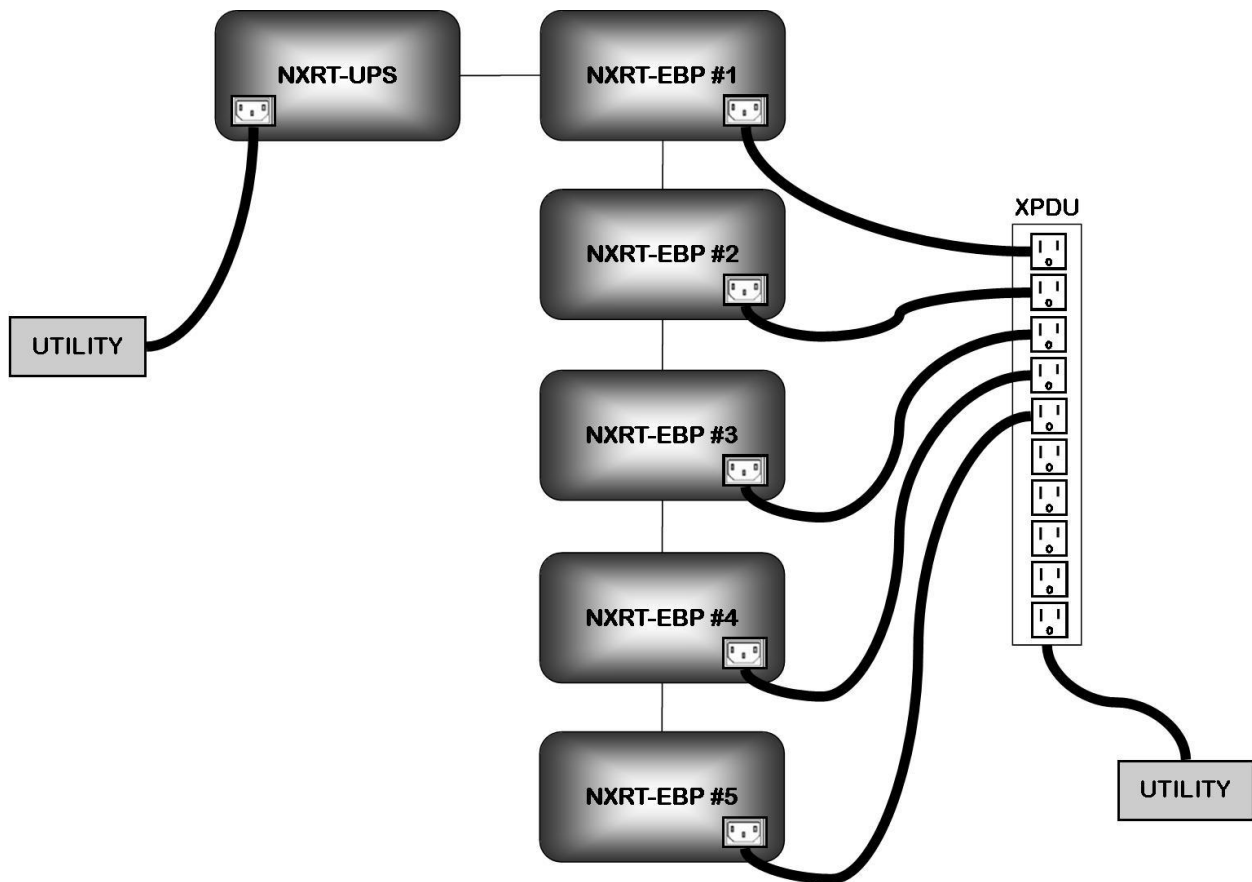
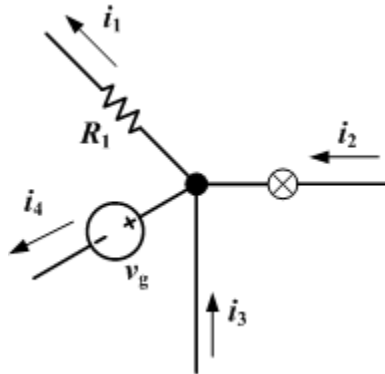

Figure 3

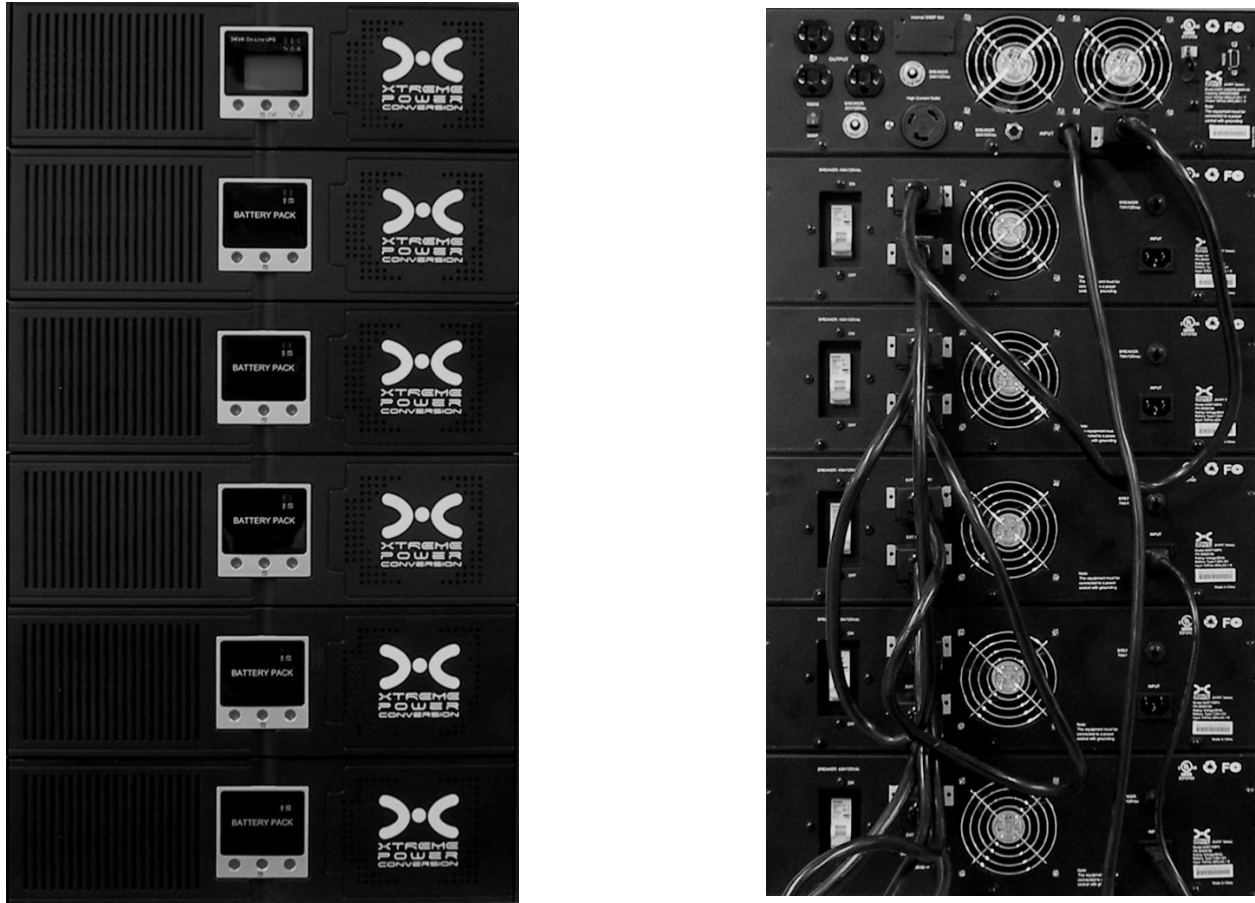

**Figure 4 Kirchhoff's Current Law**

***At any node or junction in an electrical circuit, the sum of currents flowing into that node is equal to the sum of currents flowing out of that node.***

For example, the NXRT UPS charger is rated for 1 Amp, and each battery pack charger is rated for 2 Amps so if 4 battery packs are utilized, there will be a total of 9 Amps available to charge the batteries. The system adds the needed charging current every time another battery pack is added. While the NXRT user manual recommends connecting every third NXRT-EBP to the external AC source, you could connect all NXRT-EBPs to the external AC source to provide even faster battery recharge. Please reference the chart below that estimates the recharge.

<b>% of chargers connected to AC</b>	<b>25%</b>	<b>50%</b>	<b>75%</b>	<b>100%</b>
<b>Approximate recharge time (hours) to 90% capacity</b>	<b>16</b>	<b>8</b>	<b>6</b>	<b>4</b>



*Figure 5 NXRT-EBPs “daisy chain” connected to NXRT-UPS & other EBPs*

## **Conclusion:**

In single phase UPS applications where a longer runtime is needed, there are few desirable options available for IT management. This includes over sizing the UPS for the given load to accommodate the desired run time. Often this creates additional upfront costs while sacrificing system growth in order to meet future runtime requirements if the batteries cannot be expanded. Integrating additional chargers to UPS battery pack designs has proven to be the most desirable solution for long runtime applications on the market today. This solution enables the UPS system to reach required runtime, and recharge goals without over sizing the UPS. UPS systems containing optional battery pack chargers, such as Xtreme Power Conversion Corporation’s NXRT, should be considered when long back up time is required.

## **About Xtreme Power Conversion Corporation:**

Xtreme Power Conversion Corporation is a leading American manufacturer of Uninterruptible Power Systems (UPS) and associated distribution and protection equipment. Xtreme Power is headquartered in Denver, Colorado USA. We design, produce and deliver power quality and data center solutions that solve real-world customer problems while providing the best cost to performance ratio in the industry.

**This White Paper Authored by:**

**Mike Conlon, Technical Manager, Xtreme Power Conversion Corporation**

**Xtreme Power Conversion Corporation  
230 Yuma Street  
Denver, CO 80223  
800.582.4524**

**[www.xpcc.com](http://www.xpcc.com)**